

TECHNICAL MANUAL

**OPERATOR'S, UNIT, AND DIRECT SUPPORT,
MAINTENANCE MANUAL**

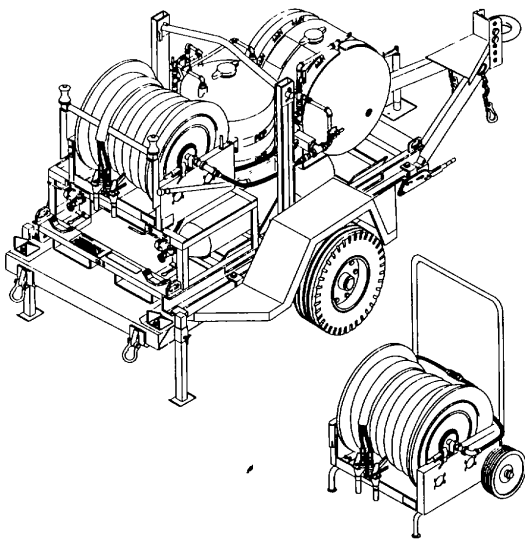

**FIRE SUPPRESSION
EQUIPMENT
SET
MODEL FSES-1
(NSN 4210-01-370-4912)**

OPERATING INSTRUCTIONS	2-1
OPERATOR PREVENTIVE MAINTENANCE CHECKS AND SERVICES (PMCS)	2-9
OPERATOR TROUBLESHOOTING PROCEDURES	3-1
UNIT MAINTENANCE INSTRUCTIONS	4-1
UNIT PREVENTIVE MAINTENANCE CHECKS AND SERVICES (PMCS)	4-4
UNIT TROUBLESHOOTING	4-12
DIRECT SUPPORT MAINTENANCE INSTRUCTIONS	5-1
MAINTENANCE ALLOCATION CHART	B-1

DISTRIBUTION STATEMENT A: Approved for public release; distribution is unlimited.

**HEADQUARTERS, DEPARTMENT OF THE ARMY
30 SEPTEMBER 1994**

WARNING

120/240 Volt AC is used in operation of this equipment DEATH on contact may result if personnel fail to observe safety precautions.

WARNING

The pressure in a nitrogen cylinder can exceed 2000 psi (13800 kPa) which could cause serious personal injury. System pressure must be relieved before servicing the equipment Nitrogen Is an inert gas that can cause suffocation and must be discharged in a well ventilated area to avoid personal injury.

WARNING

Adhesive remover is flammable and the vapors can be explosive. Keep away from sparks or flame.

Repeated or prolonged skin contact or inhalation of adhesive remover vapors can be toxic Use in a well ventilated area and wear gloves.

WARNING

Do not perform any maintenance on equipment that Is not properly supported when lifted. Personal injury can result from equipment falling or being dropped.

Special heat resistant clothing, including hood, coat, pants, gloves and boots, must be worn while fighting any large scale petroleum fire. Injury to personnel can result if not properly protected.

A minimum of two and preferably three personnel are required to operate the fire suppression equipment trailer set. Injury can result from moving hoses when in operation.

WARNING

Burning hydrocarbons produce toxic smoke. Avoid smoke Inhalation to prevent personal injury **WARNING** Equipment Is provided with hand brakes only and Is not equipped with lights or reflectors Not intended for over the road towing, personal injury can result.

See FM 21-11, First Aid For Soldiers.

a/(b blank)

TECHNICAL MANUAL

NO. 10.4210-235-13

HEADQUARTERS
DEPARTMENT OF THE ARMY
WASHINGTON, D.C, 30 September 1994

TECHNICAL MANUAL

OPERATOR'S, UNIT, AND DIRECT SUPPORT MAINTENANCE MANUAL

**FIRE SUPPRESSION EQUIPMENT SET
MODEL FSES-1
(NSN 4210-01-370-4912)**

REPORTING ERRORS AND RECOMMENDING IMPROVEMENTS

You can help improve this manual. If you find any mistakes or if you know of a way to improve these procedures, please let us know. Mail your letter or DA Form 2028 (Recommended Changes to Publications and Blank Forms), or DA Form 2028-2 located in the back of this manual directly to: Commander, US Army Aviation and Troop Command, ATTN: AMSAT-I-MP, 4300 Goodfellow Blvd., St. Louis, MO 63120-1798. A reply will be furnished directly to you.

DISTRIBUTION STATEMENT A: Approved for public release; distribution is unlimited.

TABLE OF CONTENTS

	<u>Page</u>
CHAPTER 1 INTRODUCTION	1-1
Section I. General Information	1-1
Section II. Equipment Description	1-2
Section III Principles of Operation	1-7
CHAPTER 2 OPERATING INSTRUCTIONS	2-1
Section I. Description and Use of Operator's Controls and Indicators	2-2
Section II Operator Preventive Maintenance Checks and Services (PMCS)	2-9
Section III Operation Under Usual Conditions	2-31
Section IV. Operation Under Unusual Conditions	2-53
CHAPTER 3 OPERATOR MAINTENANCE INSTRUCTIONS	3-1
Section I Lubrication Instructions	3-1
Section II Operator Troubleshooting Procedures	3-1
Section III. Maintenance Procedures.....	3-4

TABLE OF CONTENTS - continued

	<u>Page</u>
CHAPTER 4 UNIT MAINTENANCE INSTRUCTIONS	4-1
Section I Lubrication Instructions	4-1
Section II. Repair Parts, Tools, Special Tools, Test, Measurement and Diagnostic Equipment (TMDE), and Support Equipment.	4-1
Section III. Service Upon Receipt	4-1
Section IV. Unit Preventive Maintenance Checks and Services (PMCS)	4-4
Section V. Unit Troubleshooting	4-12
Section VI Maintenance Procedures.....	4-14
Section VII Preparation for Storage or Shipment.....	4-80
CHAPTER 5. DIRECT SUPPORT MAINTENANCE INSTRUCTIONS	5-1
Section I. Repair Parts, Tools, Special Tools, Test, Measurement And Diagnostic Equipment (TMDE), And Support Equipment	5-1
Section II. Troubleshooting	5-1
Section III Maintenance Procedures	5-1
APPENDIX A REFERENCES	A-1
APPENDIX B MAINTENANCE ALLOCATION CHART	B-1
Section I. Introduction	B-1
Section II. Maintenance Allocation Chart for Fire Suppression Equipment Set	B-4
Section III. Tool and Test Equipment Requirements For Fire Suppression Equipment Set	B-7
Section IV. Remarks for Fire Suppression Equipment Set	B-7
APPENDIX C. COMPONENTS OF END ITEM (COEI) AND BASIC ISSUE ITEMS (BII) LISTS	C-1
Section I Introduction	C-1
Section II. Components of End Item	C-2
Section II. Basic Issue Items	C-4
APPENDIX D. ADDITIONAL AUTHORIZATION LIST (AAL)	D-1
Section I. Introduction	D-1
Section II. Additional Authorized Items List	D-2
APPENDIX E. EXPENDABLE AND DURABLE ITEMS LIST	E-1
Section I. Introduction	E-1
Section II Expendable and Durable Items List	E-2
APPENDIX F LUBRICATION INSTRUCTIONS.....	F-1
APPENDIX G. ILLUSTRATED LIST OF MANUFACTURED ITEMS	G-1
APPENDIX H. MANDATORY REPLACEMENT PARTS LIST.....	H-1

		<u>Page</u>
GLOSSARY	Glossary-1
Section I.	Abbreviations.....	Glossary-1
Section II	Definition of Unusual Terms	Glossary-2
INDEX.	Index-1

LIST OF TABLES

<u>Table</u>		<u>Page</u>
2-1	Operator Preventive Maintenance Checks and Services for Fire Suppression Equipment Set	2-10
2-2	Dry Chemical Tank Refill Table.....	2-32
2-3	AFFF Tank Refill Table	2-34
2-4	Dry Chemical Tank Refill Table	2-47
2-5	AFFF Tank Refill Table	2-49
2-6	Nitrogen Cylinder Pressure/Temperature Chart	2-53
4-1	Unit Preventive Maintenance Checks and Services for Fire Suppression Equipment Trailer Set	4-5
4-2	Cold Weather Range	4-17

LIST OF ILLUSTRATIONS

<u>Figure</u>		<u>Page</u>
1-0	Fire Suppression Equipment	1-0
1-1	Location and Description of Major Components for Trailer Mounted Extinguisher Assembly	1-3
1-2	Location and Description of Major Components for the Auxiliary Mobile Hose Reel Cart	1-5
1-3	Trailer Mounted Extinguisher Flow Diagram.....	1-8
2-1	AFFF System Controls and Indicators	2-3
2-2	Dry Chemical System Controls and Indicators.....	2-5
2-3	Trailer Mounted Extinguisher Hose Reel Controls	2-6
2-4	Auxiliary Cart Hose Reel Controls.....	2-7
2-5	Trailer Controls	2-8
2-6	Filling Dry Chemical Tank.....	2-31
2-7	Filling AFFF Tank	2-33
2-8	Ready State Valve Position	2-35
2-9	Location of Trailer Mounted Fire Extinguisher and Remote Hose Reel Cart	2-36
2-10	Equipment Setup	2-37
2-11	Unwind Hose Assembly From Trailer Mounted Extinguisher Assembly	2-39
2-12	Auxiliary Mobile Hose Reel Cart Hose Connection	2-40
2-13	Nitrogen Cylinder Valves and Valve Rods Operational Setting	2-41
2-14	Unwind Hose Assembly from Drum.....	2-41
2-15	Close Chemical Agent Shut-off Valves.....	2-42
2-16	Ball Valve Settings for Clearing Hoses	2-43
2-17	Fire Hose Nozzles	2-44
2-18	Reset Nitrogen Cylinder Valves to Operational Ready Condition	2-44
2-19	Return Mobile Hose Reel Cart to Ready Condition.....	2-45
2-20	Return Fire Hose Nozzle to Operational Ready Condition	2-46

LIST OF ILLUSTRATIONS - continued

<u>Figure</u>		<u>Page</u>
2-21	Refill Dry Chemical Tank	2-47
2-22	Refill AFFF Tank	2-48
2-23	Information Plates (Sheet 1 of 2).....	2-50
2-24	Preparation for Movement	2-52
3-1	Operator Troubleshooting Items	3-3
4-1	Cylinder Hose Connection	4-3
4-2	AFFF Solution	4-12
4-3	Cylinder Valves	4-15
4-4	Ball Valves	4-16
4-5	Cylinder Removal	4-16
4-6	ID Plate	4-19
4-7	Accessories	4-22
4-8	Nozzle Bracket and Quick Coupling Half Disconnect	4-24
4-9	Hoses	4-26
4-10	Regulators	4-29
4-11	Hose Removal	4-32
4-12	Hose Assembly	4-33
4-13	Hose Roller Assembly Removal	4-36
4-14	Hose Roller Assembly	4-37
4-15	Hose Reel Assembly	4-39
4-16	Drum Assembly	4-40
4-17	Rewind Brake Assembly	4-42
4-18	Lift Bar Assembly	4-44
4-19	Dry Chemical Tank Removal	4-46
4-20	Dry Chemical Tank Assembly	4-48
4-21	Gas Tube Assembly Dimensions	4-49
4-22	AFFF Tank Heater Assembly	4-52
4-23	AFFF Tank Heater Wiring Diagram	4-54
4-24	AFFF Tank Heater Electrical Schematic	4-55
4-25	AFFF Tank Assembly Removal	4-58
4-26	AFFF Tank Assembly	4-59
4-27	Skid Frame Repair Items	4-63
4-28	Jack Stand, Rear	4-64
4-29	Jack	4-66
4-30	Tires/Wheels	4-68
4-31	Parking Brakes.....	4-69
4-32	Parking Brake Adjustment	4-71
4-33	Trailer	4-73
4-34	Hoses	4-78
4-35	Hose Reel Cart	4-79
5-1	Dry Chemical Nozzle Assembly	5-4
5-2	Valve Assembly	5-5
5-3	AFFF Nozzle Assembly.....	5-7
5-4	Valve Assembly	5-8
5-5	Skid Frame	5-10

HOW TO USE THIS MANUAL

Be sure to read all Warnings before using your equipment

This manual contains instructions for operation and maintenance of the Fire Suppression Equipment Set.

MANUAL OVERVIEW

a. Index Tabs.

Notice the front cover index of this manual. It lists the most important areas of the manual and guides you to those sections. Follow the black mark on the cover index edge through the pages to the edge mark on the section you want. The subjects on the front cover index are also highlighted in the table of contents by boxes A detailed alphabetical index is located at the back of this manual.

b. Contents.

The following gives you a summary of each chapter and appendix. Before beginning a maintenance task, you must familiarize yourself with the entire procedure.

- Chapter 1 - Introduces you to the equipment and gives you information such as weight, dimensions, abbreviations used and information on how the unit works.
- Chapter 2 - Provides information necessary to identify and use the equipment. Operating instructions in this chapter tell you how to use the equipment in both usual and unusual weather conditions.
- Chapter 3 - Provides operator troubleshooting procedures for identifying equipment malfunctions and maintenance procedures for performing operator maintenance tasks.
- Chapter 4 - Provides unit maintenance personnel with troubleshooting procedures for identifying equipment malfunctions and maintenance procedures for repairing defective equipment.
- Chapter 5 - Provides direct support maintenance personnel with maintenance instructions for performing repairs on equipment as authorized by the maintenance allocation chart.
- Appendix A - Provides a list of frequently used forms and publications referenced or used in this manual.
- Appendix B - The maintenance allocation chart identifies repairable components and the maintenance level authorized to perform the repairs.
- Appendix C - Lists components that are not mounted on the equipment, but are required to make the unit functional Appendix D Lists additional equipment authorized for your unit for use with the Fire Suppression Equipment Set.
- Appendix E- Provides you with information about expendable supplies such as sealants, lubricants, chemicals, etc. that are used when operating or maintaining the equipment.
- Appendix F - Provides you with information about the equipment lubrication maintenance.
- Appendix G - Provides a list of Manufactured items Appendix H -Provides a list of parts that must be replaced during maintenance of equipment.
- Glossary - Lists terms and abbreviations used in this manual and their definitions.
- Index - Lists subject matter contained in manual in alphabetical order.

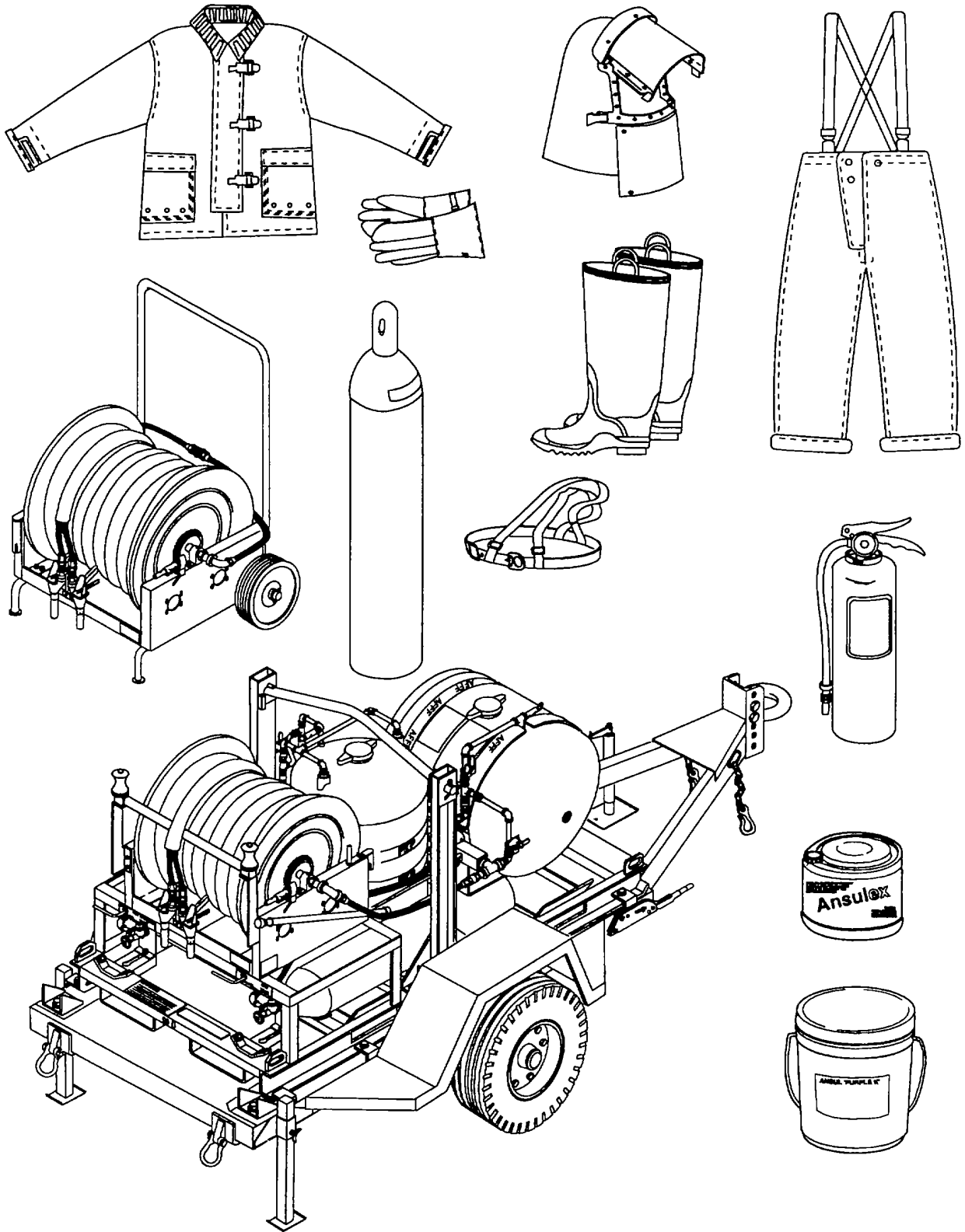

Figure 1-0. Fire Suppression Equipment

CHAPTER 1 INTRODUCTION

Section I. GENERAL INFORMATION

1-1. SCOPE.

a. This manual covers operators, unit, and direct support maintenance of the Fire Suppression Equipment Set, Model FSES-1.

b. The equipment covered by this manual is intended for fire protection of bulk fuel systems. In particular, large, light weight, nylon impregnated or polyester bladder type fuel tanks. The tanks are set up in tank farms of six each within the Tactical Petroleum Terminal portion of the Inland Petroleum Distribution System.

c. This manual also covers the accessory 150 foot (46 meter) auxiliary cart which extends the coverage area of the Fire Suppression Equipment Set to include an entire tank farm. Also included are Instructions for preparing the equipment for storage and shipment.

1-2. MAINTENANCE FORMS AND PROCEDURES

Department of the Army forms and procedures used for equipment maintenance will be those prescribed by DA Pam 738-750 as contained in the Maintenance Management Update.

1-3 CORROSION PREVENTION AND CONTROL (CPC).

a. Corrosion Prevention and Control (CPC) of Army materiel is a continuing concern. It is Important that any corrosion problems with this item be reported so that the problem can be corrected and Improvements can be made to prevent the problem in future items.

b. While corrosion is typically associated with rusting of metals, it can also include deterioration of other materials, such as rubber and plastic. Unusual cracking, softening, swelling, or breaking of these materials may be a corrosion problem.

c. If a corrosion problem is identified, it can be reported using Standard Form 368, Product Quality Deficiency Report. Use of keywords such as "corrosion, "rust," deterioration," or "cracking" will ensure that the information is identified as a CPC problem.

d. The form should be submitted to the address specified in DA PAM 738-750.

1-4 DESTRUCTION OF ARMY MATERIEL TO PREVENT ENEMY USE.

Refer to TM 750-244-3 (Destruction of Army Materiel to Prevent Enemy Use)

1-5 REPORTING EQUIPMENT IMPROVEMENT RECOMMENDATION (EIR)

If your Fire Suppression Equipment Set needs improvement, let us know Send us an EIR You, the user, are the only one who can tell us what you don't like about your equipment. Let us know why you don't like the design or performance Put it on an SF 368 (Product Quality Deficiency Report) Mail it to us at Commander, U S Army Aviation and Troop Command, ATTN.AMSAT-I-MDO, 4300 Goodfellow Blvd, St. Louis, MO 63120-1798. We will send you a reply.

Section II. EQUIPMENT DESCRIPTION

1-6. EQUIPMENT CHARACTERISTICS, CAPABILITIES, AND FEATURES.

a. **CHARACTERISTICS.** The Fire Suppression Equipment Set is skid mounted and attached to a wheeled trailer that can be easily relocated when necessary. It is equipped with two fire fighting agents designed to be effective in fighting fires generated by hydrocarbon fuels. These agents are a dry chemical and an Aqueous Film Forming Foam (AFFF). The dry chemical extinguishes fires by breaking up flame propagation, and is compatible with mechanical foam. Water mixed with the Aqueous Film Forming Foam agent concentrate forms a foam which is then used to form a film over the extinguished area, preventing re-ignition. These two agents are stored in containers on the Fire Suppression Equipment Set, making the unit self-contained.

b. **CAPABILITIES.** The Fire Suppression Equipment Set has the capability of extinguishing a fire from a 20,000 gallon (75,160 liter) tank of 100/130 aviation gas in a 1500 square foot (139 square meter) berm (diked area). A 150-foot (46-meter), non-collapsible hose and discharge nozzle is provided for dispersing the chemical agents. An Auxiliary mobile hose reel cart is provided with a second hose reel of 150-feet (46 meters) that can be connected to the end of the hose from the unit to provide additional area coverage without moving the entire Fire Suppression Equipment Set.

c. **FEATURES.** The unit is built for rugged use and is treated with corrosion resisting coatings making it extremely durable over a wide range of climatic conditions. The chemical agents discharge hoses are encased in a single cover for convenient storage and use and are linked by a tie bar at the nozzles. The hoses are stored on a hose reel at the front of the unit when not in use. The hose ends and nozzles are equipped with quick-disconnect fittings which allow rapid connection of the auxiliary cart. The skid mounted Fire Suppression Equipment Set can be un-bolted from the wheeled trailer and removed. A lifting bar is provided to lift the unit from the cart and slots are provided for lifting with a fork-lift. Tiedown eyes are provided to anchor the unit and cart to a truck-bed or aircraft floor. The Fire Suppression Equipment Set can operate down to -40° F (-40° C) by using an electric heater around the AFFF tank to keep the water mixed solution from freezing.

d. **LIMITATION.** At least two, and preferably three highly skilled operators are required to fight a berm fire with this equipment, one manning the nozzle and the others to assist in dragging and maneuvering the hoses or replacing the nozzle operator if necessary. The unit has only a 40-50 foot (12-15 meter) range requiring close-in position and therefore it is mandatory that all operating personnel wear protective clothing.

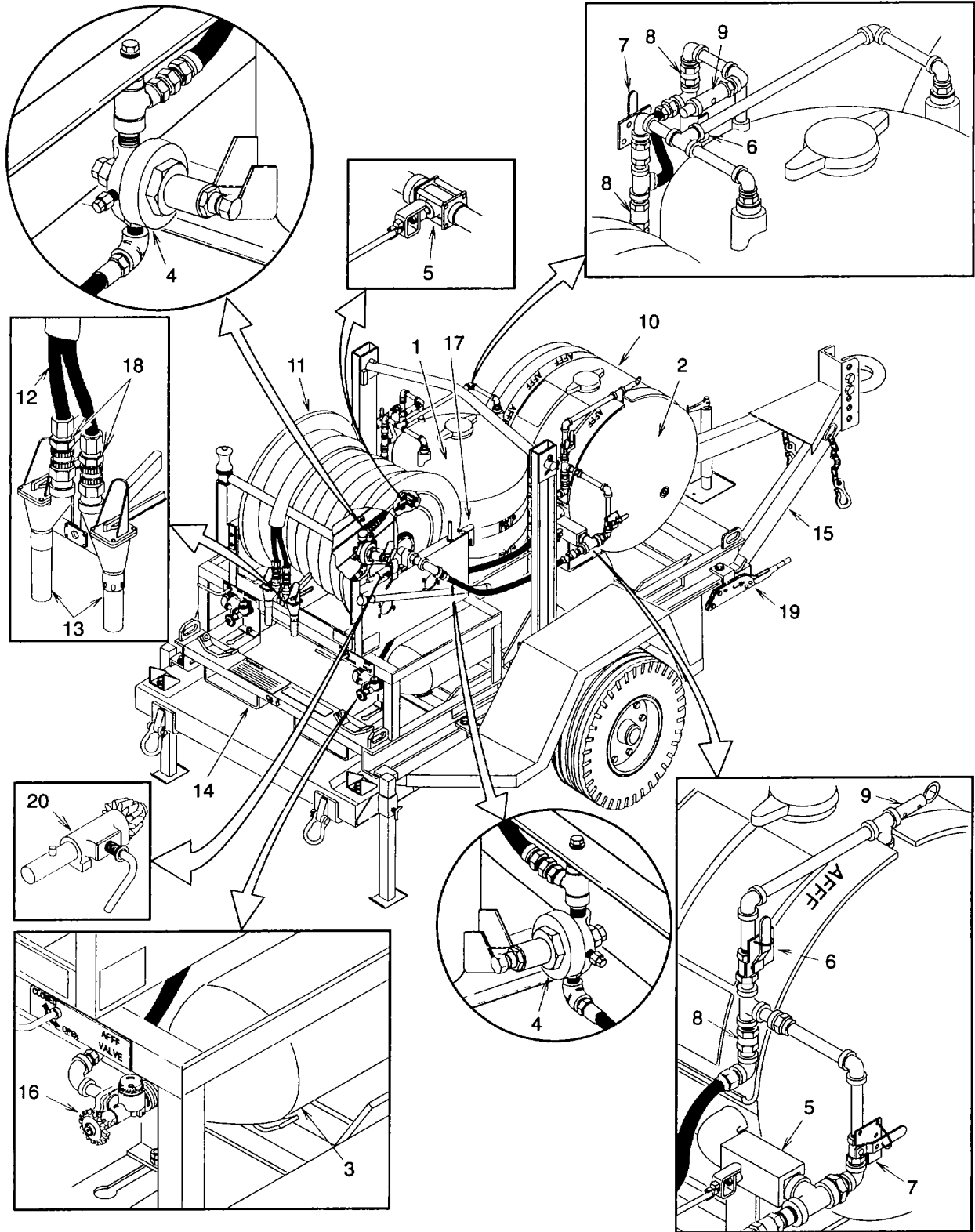

Figure 1-1. Location and Description of Major Components for Trailer Mounted Extinguisher Assembly

1. DRY CHEMICAL TANK. Holds 450 pounds (204 kilograms) of dry chemical agent at 220-240 psi (1518-1656 kPa) operating pressure.
2. AFFF TANK. Holds 100 gallons (376 liters) of AFFF mix (water and AFFF concentrate) at 220-240 psi (1518-1656 kPa) operating pressure. The tank is lined for corrosion protection and has an electric heater around it to prevent freezing.
3. CYLINDERS Assembly. Two are provided, each pressurizes one fire-fighting agent tank. Each cylinder contains 300 cubic feet (85 cubic meters) of nitrogen at 2400 psi (16560 kPa) when fully charged. Quick opening lever operated valves are provided for ease of use.
4. REGULATING VALVES. High volume pressure regulators that are preset to reduce nitrogen pressure to 220-240 psi (1518-1656 kPa) working pressure.
5. BALL VALVES. Control flow of fire-fighting agent (to pressurize tank) or nitrogen (for hose blowdown) through discharge plumbing.
6. BALL VALVES. Control flow of nitrogen to the fire-fighting agent tank.
7. BALL VALVES. Control flow of nitrogen to the hose lines to clean and dry them.
8. CHECK VALVES. Prevent back-flow of the fire-fighting agents into the respective nitrogen regulators.
9. RELIEF VALVES. Self-resetting valve set at 250 psi (1725 kPa) used to guard against over pressurization of the system.
10. HEATER ASSEMBLY. Electric heater used to heat AFFF tank when tank temperature falls below 45° F (7° C). Heater is equipped with a 120 vac male power plug and cord.
11. HOSE REEL. Used to store 150 feet (46 meters) of fire hose assembly. Equipped with hand crank to manually rewind the hose onto the reel.
12. Hose ASSEMBLY. Two one-inch (2.5 centimeters), non-collapsible hoses 150 feet (46 meters) long and encased in a woven polyester jacket. Used to carry the fire-fighting agents to the discharge nozzles.
13. FIRE HOSE NOZZLE. Used to control the flow of fire-fighting agents onto a fire and to disperse the agent in a predetermined pattern effectively for each agent.
14. SKID FRAME. Steel frame assembly to mount and support the Fire Suppression Equipment Set components. Provides a lifting bar for lifting the set as well as a lifting eye on each corner. Forklift channels are also provided for lifting.
15. TRAILER. Two wheeled trailer that the Fire Suppression Equipment Set skid is mounted on for ease of movement. Equipped with individual hand parking brakes for each wheel. An adjustable lunette is provided for towing, and tie downs are provided on each corner to secure the unit during transportation.
16. CYLINDER VALVE. Quick-opening lever operated or hand wheel operated valve to allow for quick and easy opening of cylinder.
17. CRANK ASSEMBLY. Provides means to manually rewind the fire hose assembly back onto the hose reel.
18. QUICK COUPLING HALF (Outlet). Used to quickly and easily disconnect the fire hose assembly and connect the auxiliary mobile fire hose assembly.
19. PARKING BRAKE ASSEMBLY (EACH WHEEL). When set, prevents the trailer from moving.
20. REWIND BRAKE ASSEMBLY. An adjustable drag used to prevent the hose from unwinding from hose reel under its own weight while allowing enough slip to easily pull the hose from reel when needed.

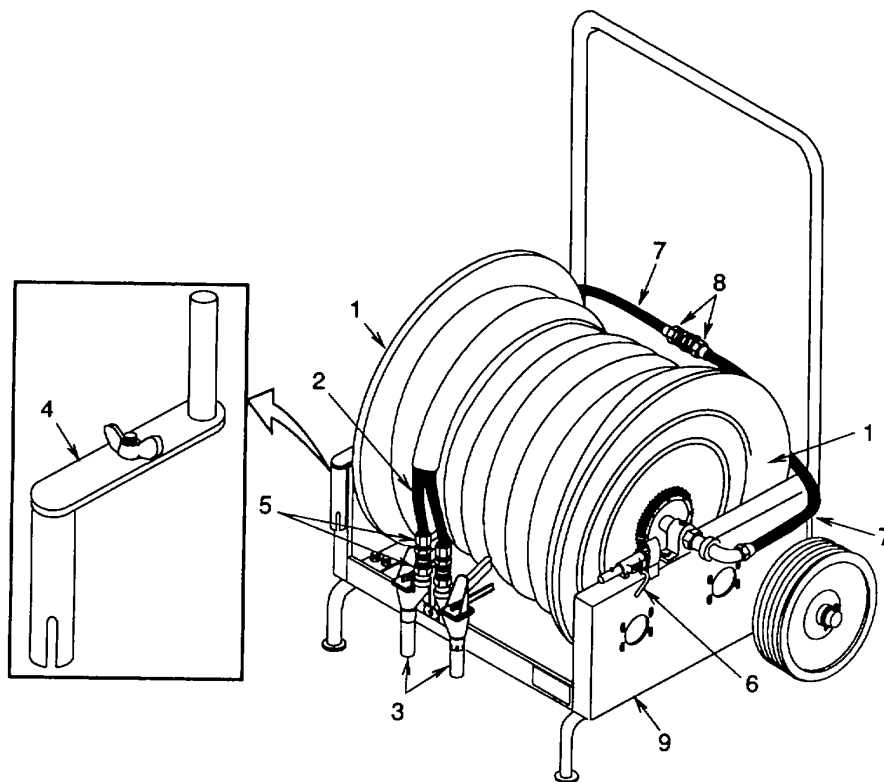

Figure 1-2. Location and Description of Major Components for the Auxiliary Mobile Hose Reel Cart

1. HOSE REEL. Used to store 150 feet (46 meters) of hose. Equipped with hand crank to manually rewind the hose onto the reel.
2. HOSE ASSEMBLY. Two one-inch, non-collapsible hoses 150 feet (46 meters) long and encased in a woven polyester jacket. Used to carry the fire-fighting agents to the discharge nozzles.
3. FIRE HOSE NOZZLE. Used to control the flow of fire-fighting agents onto a fire and to disperse the agent in a predetermined pattern effectively for each agent.
4. CRANK ASSEMBLY. Provides means to manually rewind the hose assembly back onto the hose reel.
5. QUICK COUPLING HALF (Outlet). Used to quickly and easily disconnect the fire hose nozzle assembly and connect the auxiliary cart assembly.
6. REWIND BRAKE ASSEMBLY. An adjustable drag used to prevent the hose from unwinding from hose reel under its own weight while allowing enough slip to easily pull the hose from reel when needed.
7. HOSE (Inlet). Used to connect the trailer mounted hose assembly to the auxiliary mobile hose reel.
8. QUICK COUPLING HALF (INLET). Used to quickly and easily connect the trailer mounted hose assembly to the inlet hoses.
9. AUXILIARY CART. Two wheeled cart used to carry additional hose line.

1-7 EQUIPMENT DATA.

Dimensions:

Fire Suppression Equipment Set	
Length	149 in. (379 cm)
Width	76 in. (193 cm)
Height	75 in. (191 cm)

Auxiliary Cart	
Length	48 in. (122 cm)
Width	45 in. (114 cm)
Height	59 in. (150 cm)

Weight:

Fire Suppression Equipment Set	
Without Chemical Agents (Empty N2 Cylinders)	2960 lbs (1343 kg)
Fire Suppression Equipment Set Fully Serviced	4287 lbs (1945 kg)
Dry Chemical (Potassium Bicarbonate)	450 lbs (204 kg)
AFFF Concentrate (6%)	50 lbs (23 kg)
Water	783 lbs (355 kg)
Nitrogen (N2) Per Cylinder	22 lbs (10 kg)
Auxiliary Cart	455 lbs (206 kg)

Operating Pressure

Tanks and Hoses	220-240 psi (1518-1656 kPa)
Nitrogen (N2) Cylinder	1750 psi - 2400 psi (12075 kPa - 16560 kPa)

Capacities:

Dry Chemical (Potassium Bicarbonate)	450 lbs (204 kg)
AFFF Solution (6%)	100 gal (376 l)
Nitrogen (N2)	300 cu ft (85 cu m) per cyl

Heater Power Requirements

120/240 vac, 1 ph, 60 hz, 1300 w

Flow Rates:

AFFF (150 ft (46 m) hose)	51 gpm (192 lpm)
AFFF (300 ft (91 m) hose)	40 gpm (150 lpm)
Dry Chemical (150 ft (46 m) hose)	5.0 pps (2.3 kgps)
Dry Chemical (300 ft (91 m) hose)	4.4 pps (2.0 kgps)

Continuous Flow Time:

AFFF (150 ft (46 m) hose)	1 min., 58 sec
AFFF (300 ft (91 m) hose)	2 min., 30 sec
Dry Chemical (150 ft (46 m) hose)	1 min , 19 sec
Dry Chemical (300 ft (91 m) hose)	1 min., 42 sec

Operating Temperature Range (With AFFF Heater)

-40° F to +130° F (40° C to +54° C)

Section III. PRINCIPLES OF OPERATION

1-8 FIRE SUPPRESSION EQUIPMENT SET

a. The Fire Suppression Equipment Set is a self-contained unit used to extinguish fuel fires and seal against re-ignition. It is to be kept in a ready status at all times when not in use. It must be ready to use quickly with a minimum amount of time or effort.

b. Two storage tanks hold the fire-fighting agents, one for the dry chemical and one for the AFFF. When used, the storage tanks are pressurized independently from nitrogen cylinders using quick-opening lever valves. The cylinder pressure is reduced with pressure regulators and check valves prevent the fire-fighting agents from backing up into the regulators.

c. Each storage tank has a discharge ball valve that is opened to quickly allow the fire-fighting agents to pass through the 150 foot long hoses stored on the hose reel.

d. The fire hose nozzle assembly controls the flow of fire-fighting agents from the hose line. The operator squeezes a trigger lever to discharge either agent independently onto the fire.

e. A heater is used around the AFFF storage tank to heat it if the tank temperature drops to 40° F (4° C). This is to keep the liquid agent in a fluid state.

1-9. AUXILIARY CART.

The auxiliary cart carries additional hose line (150 feet) (46 meters) that can be attached to increase the coverage area.

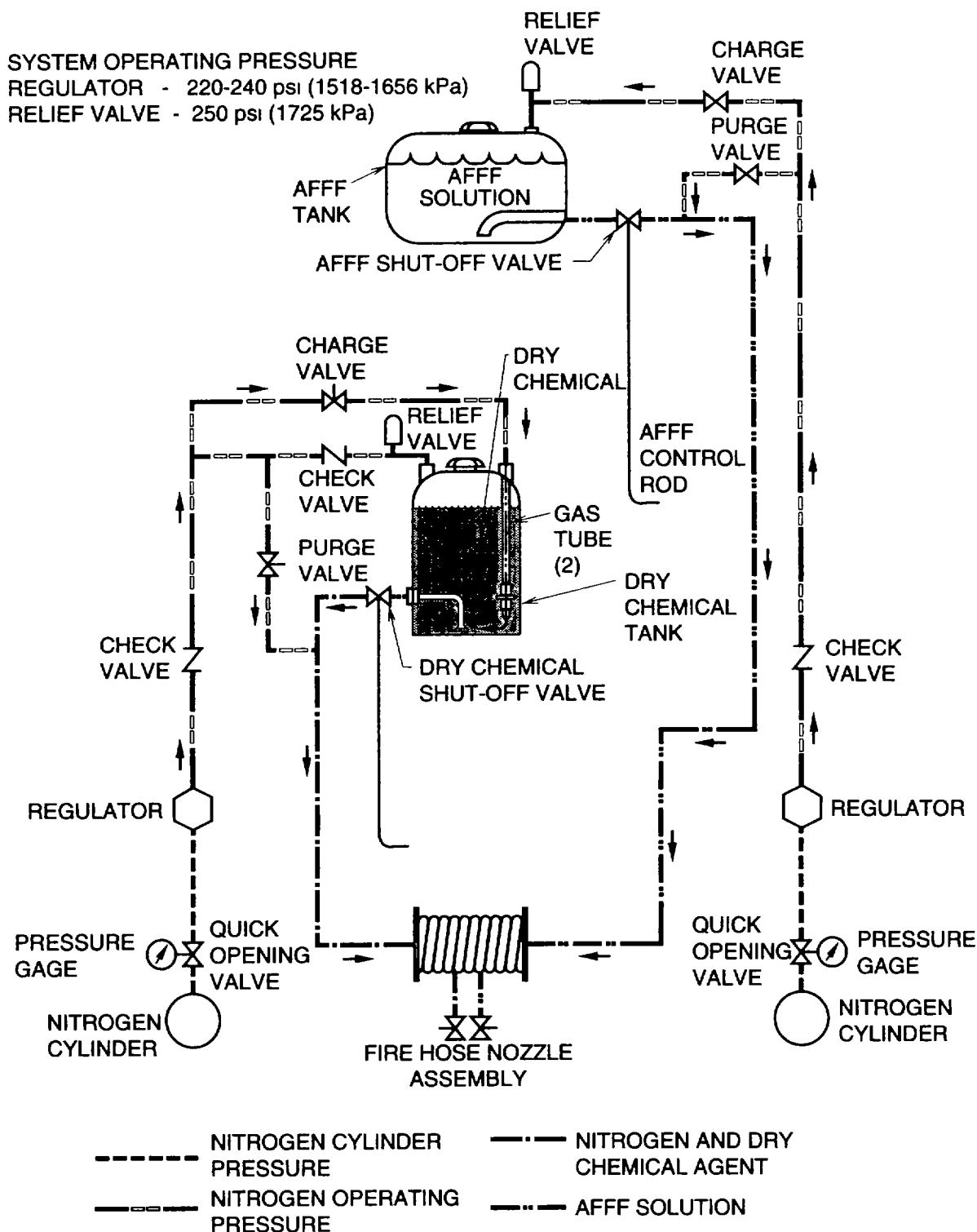

Figure 1-3. Trailer Mounted Extinguisher Flow Diagram

**CHAPTER 2
OPERATING INSTRUCTIONS**

	PAGE
Section I DESCRIPTION AND USE OF OPERATOR'S CONTROLS AND INDICATORS	2-2
2-1 Fire Suppression Equipment Set	2-2
2-2 AFFF System	2-2
2-3 Dry Chemical System	2-4
2-4 Hose Reel	2-6
2-5 Auxiliary Cart	2-7
2-6 Trailer	2-8
Section II OPERATOR PREVENTIVE MAINTENANCE CHECKS AND SERVICES (PMCS)	2-9
2-7 General	2-9
2-8 PMCS Procedures	2-9
Section III OPERATION UNDER USUAL CONDITIONS	2-31
2-9 Assembly and Preparation for Use	2-31
2-10 Operating Procedures	2-38
2-11 Decals and Instruction Plates	2-49
2-12 Preparation for Movement	2-52
Section IV OPERATION UNDER UNUSUAL CONDITIONS	2-53
2-13 Extreme Heat	2-53
2-14 Extreme Cold	2-54
2-15 Salt Air or Sea Spray	2-54
2-16 Dusty or Sandy Environment	2-54
2-17 Emergency Procedures	2-54
2-18 Nuclear, Biological, and Chemical (NBC) Decontamination Procedures	2-55

Section I. DESCRIPTION AND USE OF OPERATOR'S CONTROLS AND INDICATORS**2-1. FIRE SUPPRESSION EQUIPMENT SET.**

The controls and indicators needed to operate the fire suppression equipment set are located for easy access at the rear (hose reel end) of the unit.

2-2. AFFF SYSTEM.

See figure 2-1 for location of AFFF system controls and indicators.

1. **CYLINDER DISCHARGE VALVE**
When opened, pressurizes the AFFF system.
2. **CYLINDER PRESSURE GAGE**
Gives a continual reading of cylinder pressure. Normal reading, fully charged, 2400 psi (16560 kPa) at 70° F (21° C). Minimum pressure required for operation, 1750 psi (12075 kPa) at 700F (21° C).
3. **BALL VALVE**
Controls the pressurization of the AFFF tank.
4. **BALL VALVE**
Controls the tank bypass line to permit purging of the discharge lines and dispensing hose with nitrogen directly from the nitrogen cylinder.
5. **AFFF VALVE ROD**
Extends the AFFF shut-off valve control to the rear of the unit for easy access. Used to control outlet of AFFF tank.
6. **FIRE HOSE NOZZLE**
When the nozzle lever is squeezed, the shut-off valve opens to discharge the AFFF onto the fire.

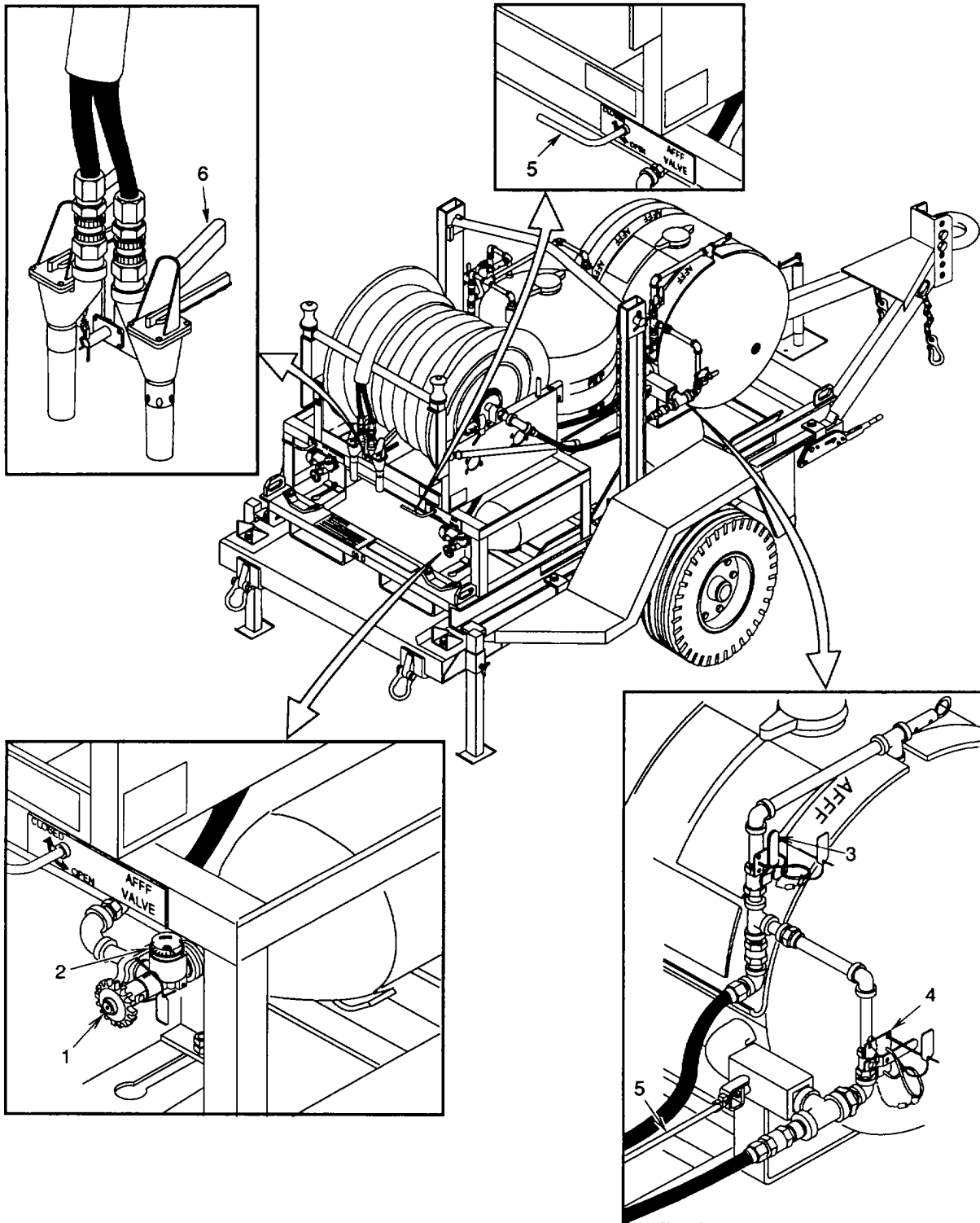

Figure 2-1. AFFF System Controls and Indicators

2-3. DRY CHEMICAL SYSTEM.

See figure 2-2 for location of dry chemical system controls and indicators.

1. **CYLINDER DISCHARGE VALVE**
When opened, pressurizes the dry chemical system.
2. **CYLINDER PRESSURE GAGE**
Gives a continual reading of cylinder pressure. Normal reading, fully charged, 2400 psi (16560 kPa) at 70° F (21° C). Minimum pressure required for operation, 1750 psi (12075 kPa) at 70° F (21° C).
3. **BALL VALVE**
Controls the pressurization of the dry chemical tank.
4. **BALL VALVE**
Controls the tank bypass line to permit purging of the discharge lines and dispensing hose with nitrogen directly from the nitrogen cylinder.
5. **RY CHEMICAL VALVE ROD**
Extends the dry chemical shut-off valve control to the rear of the unit for easy access. Used to control outlet of dry chemical tank.
6. **FIRE HOSE NOZZLE**
When the nozzle lever is squeezed, the shut-off valve opens to discharge the dry chemical onto the fire.
7. **QUICK-COUPLING HALF**
Used to remove the fire hose nozzles and attach the hose ends when connecting to the remote hose reel.

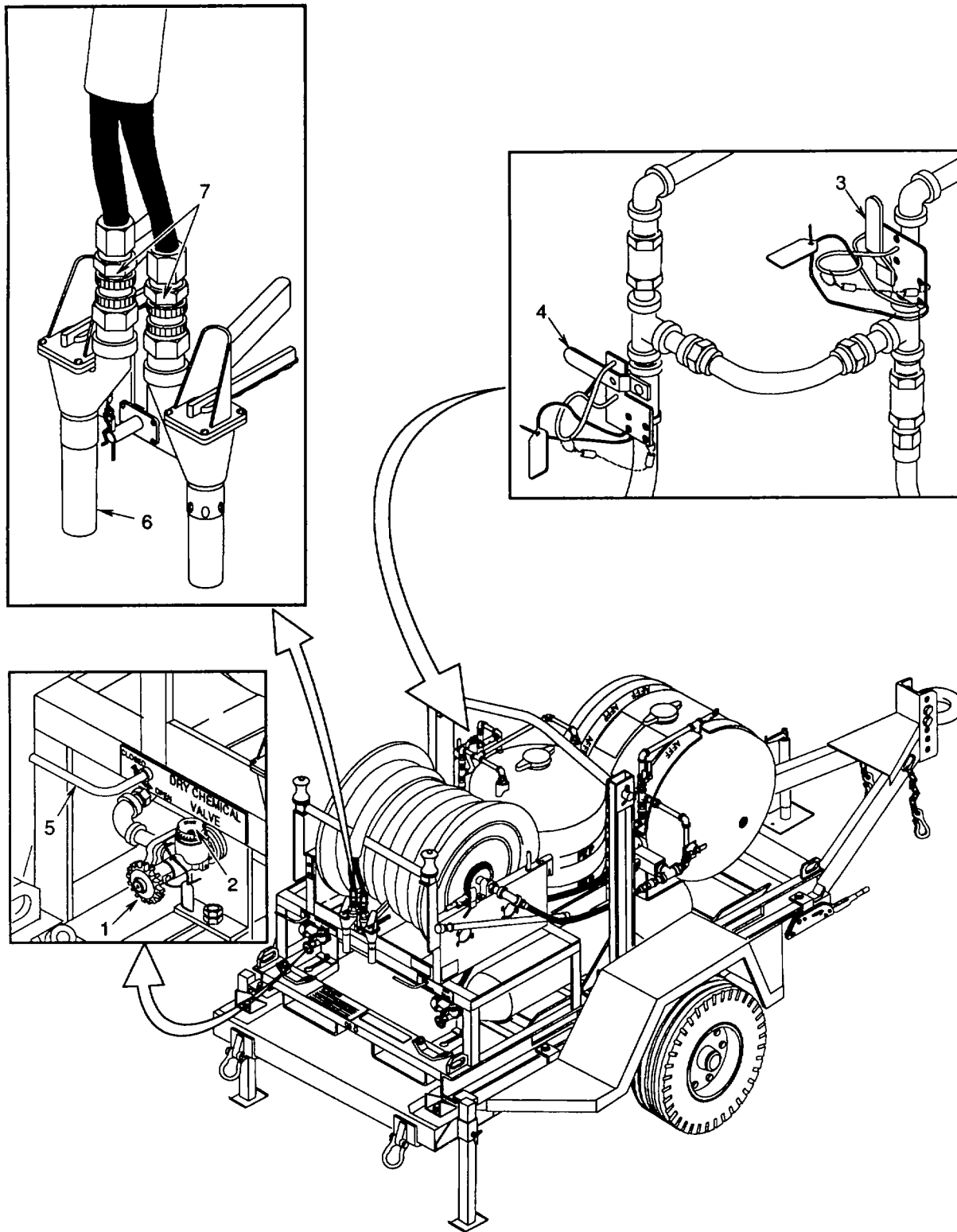

Figure 2-2. Dry Chemical System Controls and Indicators

2-4. HOSE REEL.

See figure 2-3 for location of hose reel controls.

1. CRANK
Used to rewind the hose onto the reel when placed onto the bevel gear shaft.
2. REWIND BRAKE ASSEMBLY
Used to hold the hose reel in place to prevent unwinding when stored.
3. GAGE ASSEMBLY
Used to measure the level of dry chemical or AFFF solution in the tanks so the amount can be calculated.

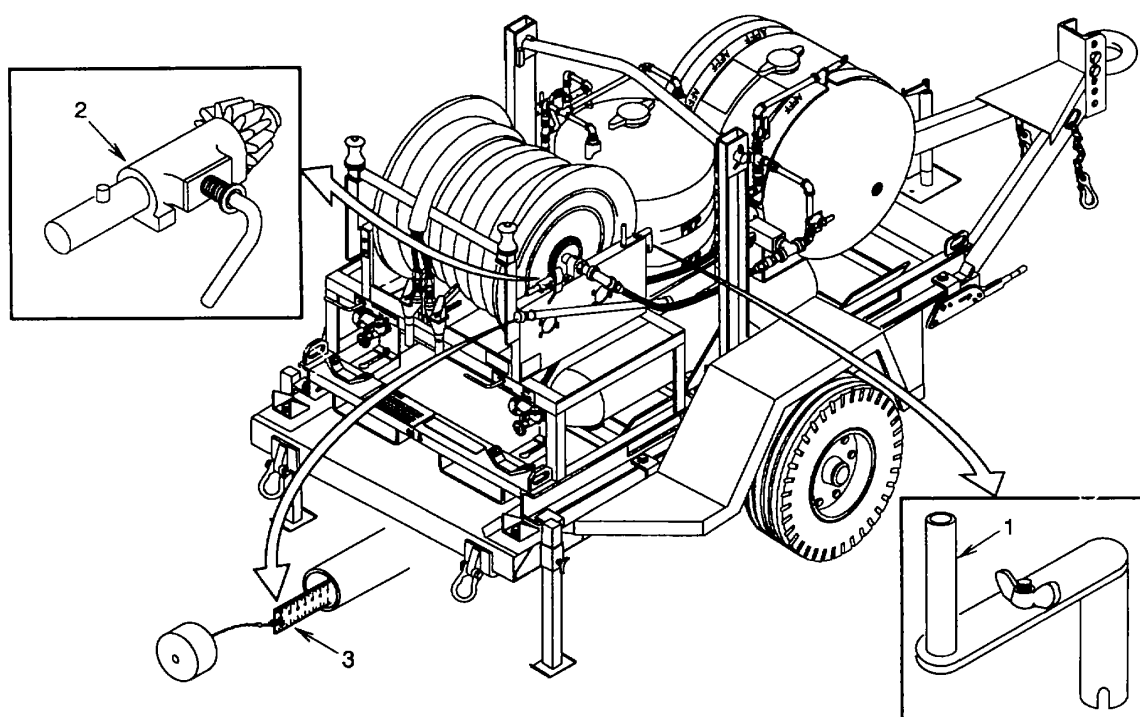

Figure 2-3. Trailer Mounted Extinguisher Hose Reel Controls

2-5. AUXILIARY CART.

See figure 2-4 for location of Auxiliary hose reel cart controls.

1. CRANK
Used to rewind the hose onto the reel when placed onto the bevel gear shaft.
2. REWIND BRAKE ASSEMBLY
Used to hold the hose reel in place to prevent unwinding when stored.
3. FIRE HOSE NOZZLE
When the nozzle lever is squeezed, the shut-off valve opens to discharge the dry chemical onto the fire.
4. QUICK COUPLING HALF
Used to attach the hose ends together when connecting to the trailer mounted extinguisher assembly.
5. HOSES (INLET)
Used to connect the trailer mounted fire hose assembly to the auxiliary hose reel.

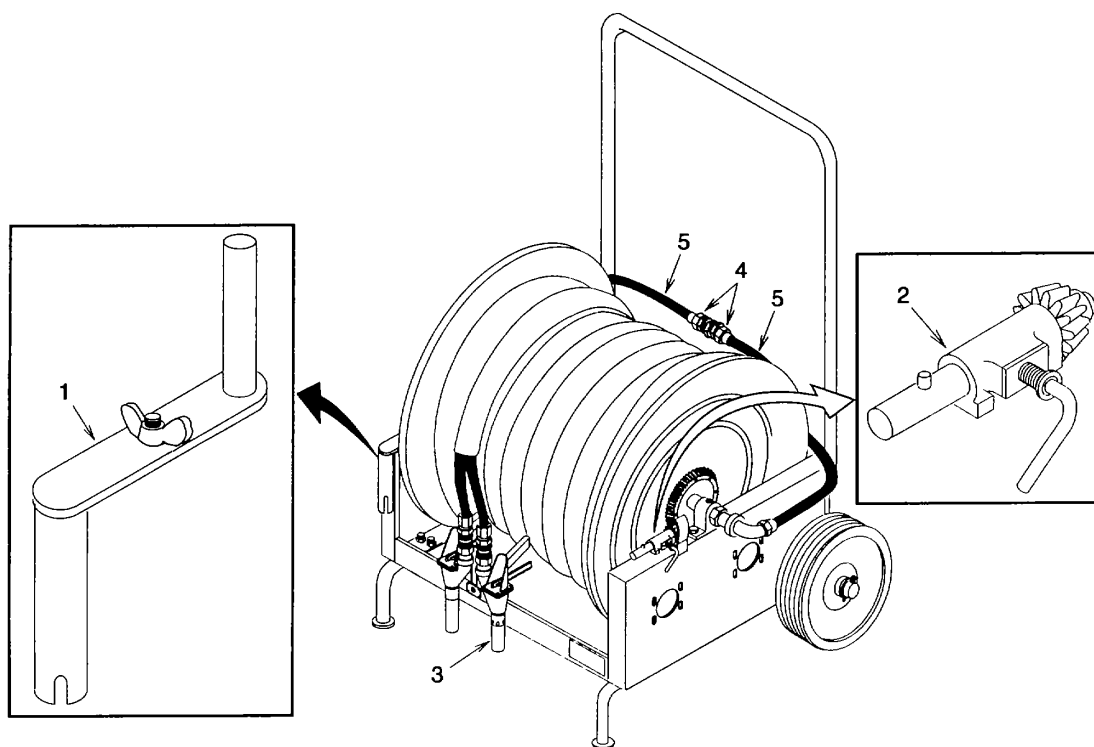

Figure 2-4. Auxiliary Cart Hose Reel Controls

2-6. TRAILER

WARNING

Equipment is provided with hand brakes only and is not equipped with lights or reflectors. Not intended for over the road towing, personal injury can result.

See figure 2-5 for location of trailer controls.

1. PARKING BRAKES
When applied, they prevent the trailer from moving when disconnected from the towing vehicle.
2. REAR JACK STAND
When lowered, they support and stabilize the trailer.
3. JACK
Used to support, stabilize, and remove the trailer from the towing vehicle.

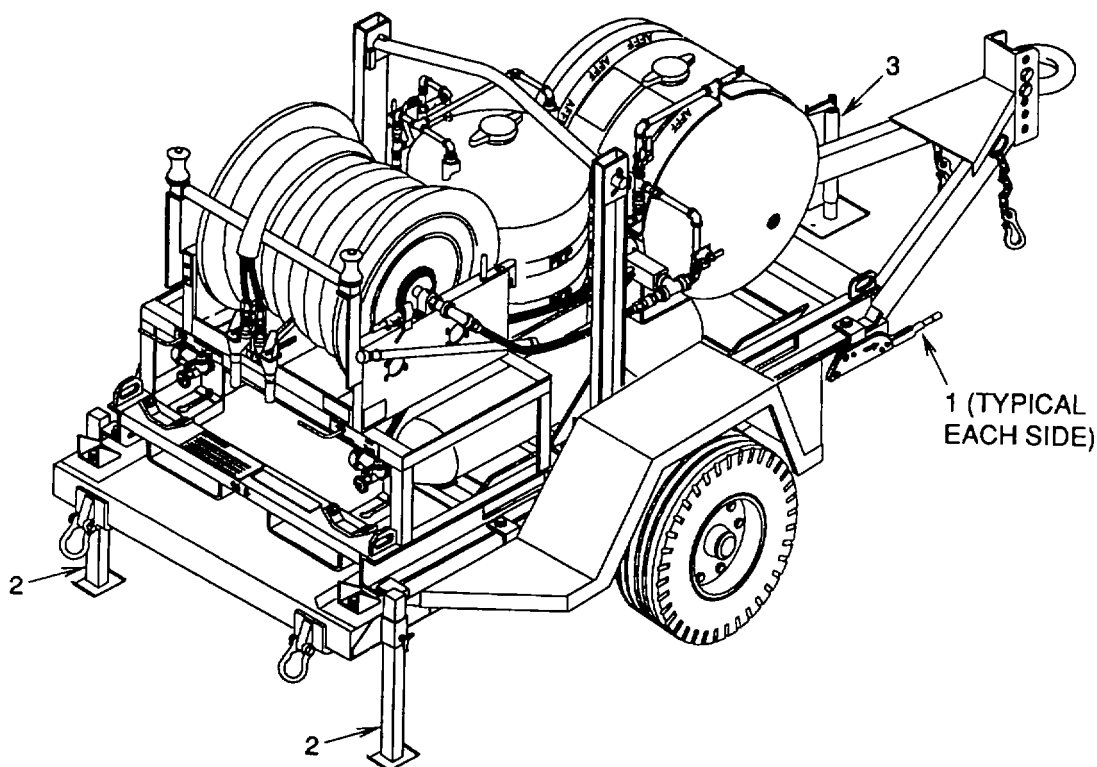

Figure 2-5. Trailer Controls

Section II. OPERATOR PREVENTIVE MAINTENANCE CHECKS AND SERVICES (PMCS)

2-7. GENERAL.

Preventive Maintenance Checks and Services means systematic caring, inspection, and servicing of equipment to keep it in good condition and ready to use. As the operator, your mission is to:

- (1) Be sure to perform your PMCS each time you use the Fire Suppression Equipment Set.
- (2) Do your "Before" PMCS Just before you use the equipment.
- (3) Do your "After" PMCS right after using the equipment.

(4) Use DA Form 2404 (Equipment Inspection and Maintenance Worksheet) to record any faults that you discover before, during, or after use, unless you can fix the fault. You DO NOT need to record faults that you fix.

2-8. PMCS PROCEDURES.

- a. Your Preventive Maintenance Checks and Services, table 2-1, lists inspections and care required to keep your equipment in good operating condition.
- b. The "Interval" column of table 2-1 tells you when to do a certain check or service
- c. The "Procedure" column of table 2-1 tells you how to do required checks and services.

NOTE

Terms "ready/available" and "mission capable" refer to same status Equipment is on hand and ready to perform its mission. (See DA Pam 738-750.)

- d. The "Equipment Is Not Ready/Available If:" column in table 2-1 tells you when your equipment is non-mission capable and why it cannot be used.

Table 2-1. Operator Preventive Maintenance Checks and Services for Fire Suppression Equipment Set

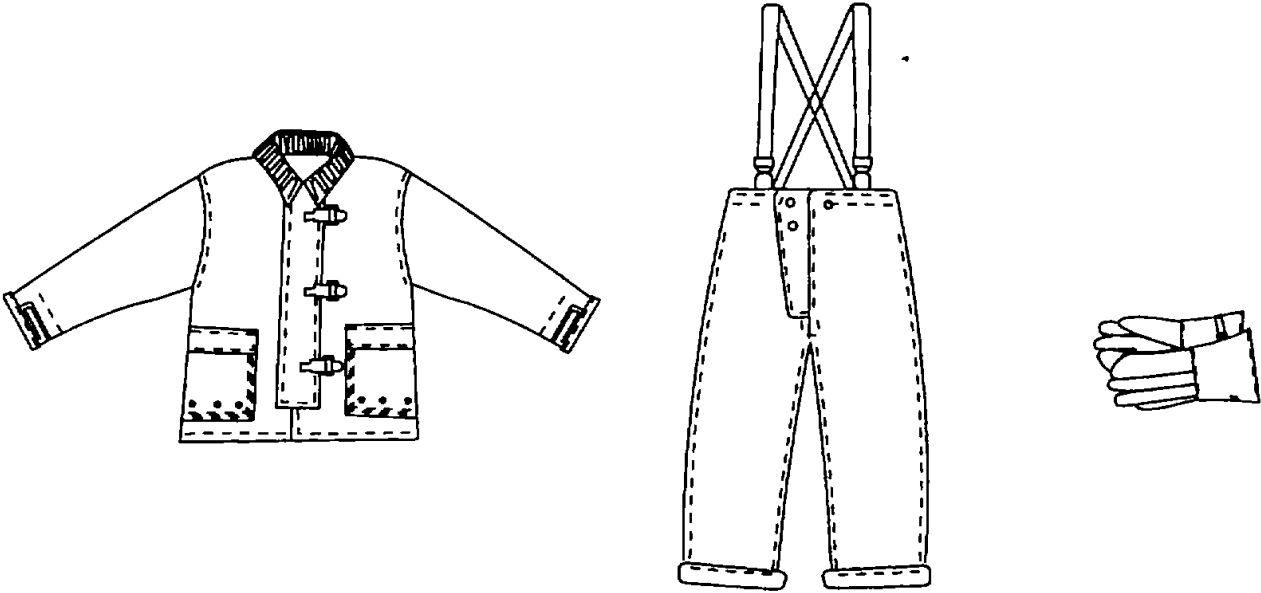
Item No	Interval	Location	Procedure	Not Fully Mission Capable If:
		Item To Be Check/Service		
				
1	Before	Coats, Trousers, Gloves	<p>a. Check that one each or pair is available per crew member.</p> <p>b. Inspect for tears, broken or missing fastening devices, flaking aluminum coating, mold, or mildew.</p> <p style="text-align: center;">WARNING</p> <p>Clothing items must be kept dry. Steam produced by high heat can cause severe burns.</p> <p>c. Liners should be dry and in place.</p>	Protective clothing missing, damaged, or damp.

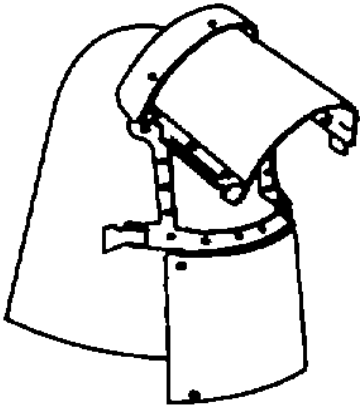
Item No	Interval	Location	Procedure	Not Fully Mission Capable If:
		Item To Be Check/Service		
2	Before	Hoods	 <ul style="list-style-type: none"> a. Check that one is available per crew member. b. Inspect for tears, flaking aluminum coating, mold, or mildew. <p style="text-align: center;">WARNING Clothing items must be kept dry. Steam produced by high heat can cause severe burns.</p> <ul style="list-style-type: none"> c. Hoods should be dry. d. Check that face shield is not broken or cracked, missing, melted, or visually distorted. e. Check that internal helmet functions properly and is not missing or damaged and that the chin strap is not missing or 	Hoods missing, damaged, or damp.

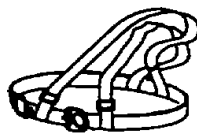
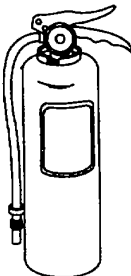
Item No	Interval	Location	Procedure	Not Fully Mission Capable If:
		Item To Be Check/Service		
3	Before	Boots	 <ol style="list-style-type: none"> Check that one pair is available per crew member. Inspect for holes, tears, flaking aluminum coating, evidence of melting, mold, or mildew. <p style="text-align: center;">WARNING</p> <p>Clothing items must be kept dry. Steam produced by high heat can cause severe burns.</p> <ol style="list-style-type: none"> Boots should be dry. 	Boots missing, damaged, or damp.
4	Before	Harness	 <p>Check that harness is not missing or damage</p>	
5	Before	Hand Held Free Extinguishers	 <ol style="list-style-type: none"> Check for dents, tears, damaged or missing hose, and broken or missing handle. Check if fully charged. 	

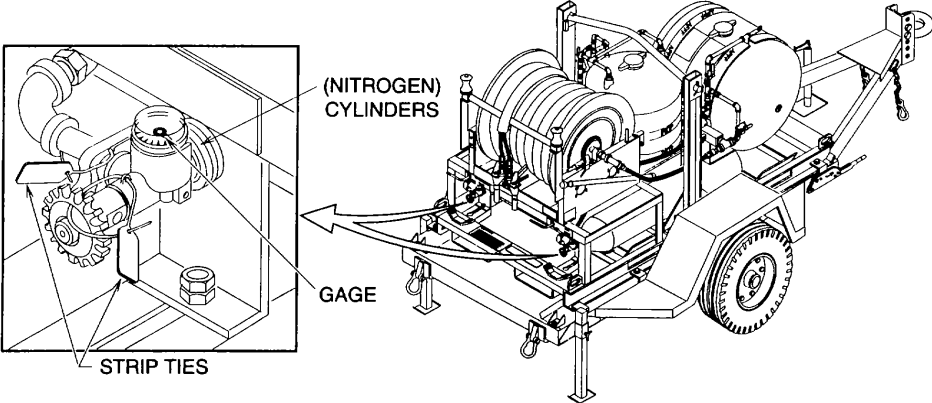
Item No	Interval	Location	Procedure	Not Fully Mission Capable If:	
		Item To Be Check/Service			
6	Before	Cylinders		<p>Check that two cylinders are installed.</p> <p>Check that strip ties are in place. Check if gage lens is cracked, broken, or missing.</p> <p>a. Normal operation:</p> <p>Check that gage indicates 1750 psi (12075 kPa) or more. Notify supervisor if below 1750 psi.</p> <p>b. Cold weather operation:</p> <p>Check that gage indicates pressures at or above those listed below for current temperature.</p> <p style="text-align: center;"><u>COLD WEATHER RANGE</u></p> <p style="text-align: center;">-40 = 1575 psi (10868 kPa) -20 = 1650 psi (11385 kPa) 0 = 1725 psi (11903 kPa) 10 = 1750 psi (12075 kPa)</p>	<p>Not installed.</p> <p>Strip ties broken or missing. Gage lens broken or missing.</p> <p>Cylinder pressure is below 1750 psi. (12075 kPa) for normal operation. (12075 kPa).</p> <p>Cylinder pressure is below cold weather operation ranges.</p>

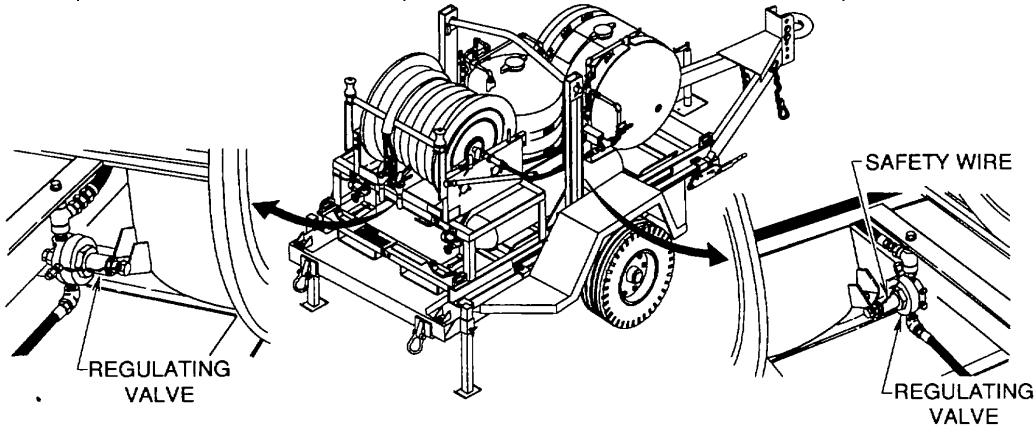
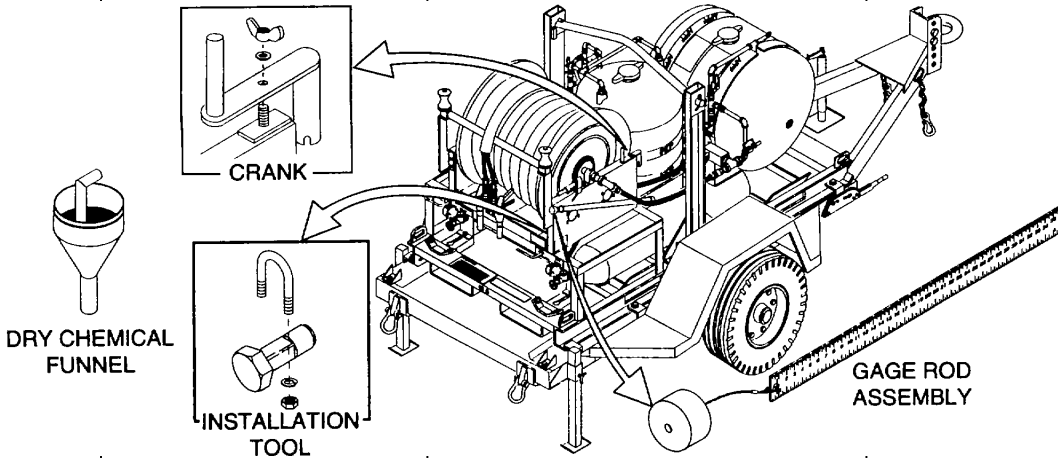
Item No	Interval	Location	Procedure	Not Fully Mission Capable If:
		Item To Be Check/Service		
				
7	Before	Regulating valves	Check for any visible damage and broken or missing safety wire.	Visibly damaged or safety wire missing.
8	Before	Name and Instruction Plates	Check that name and instruction plates are legible and in place. See figure 2-23.	
				
9	Before	Accessories	<p>Check that the following accessories are available, in good condition, and free of rust.</p> <ol style="list-style-type: none"> 1) Dry Chemical Funnel 2) Crank 3) Gage Rod Assembly 4) Installation Tool 	

Item No	Interval	Location	Procedure	Not Fully Mission Capable If:
		Item To Be Check/Service		
				
10	Before	Fire Hose Nozzle	<p>Check for obstruction in fire hose nozzle outlet.</p> <p>Check that fire hose nozzle valve levers squeeze smoothly with no binding. any gas escapes.</p> <p>Be sure fire hose nozzle is secure on nozzle bracket.</p>	<p>Fire hose nozzle is obstructed.</p> <p>Valve lever binds or is difficult to operate. Notify your supervisor if</p> <p>See paragraph 2-10.</p>
11	Before	Hose Assemblies	<p>Check that hose assemblies are tight and in good condition with no evidence of leaking or dry rot. visible damage.</p>	<p>If any hose assembly shows evidence of leakage, loose connections, dry rot, or other</p>
12	Before	Valves and Piping	<p>Check for evidence of leaking or visible damage and if strip ties are missing.</p>	<p>Damaged, leaking, or strip ties missing.</p>
13	Before	Hose Assembly	<p>Check that hose assembly is evenly wound on drum.</p> <p>Check visible portion of hose assembly to see if it is tight and in good condition with no evidence of leaking or dry rot.</p>	<p>Hose assembly not evenly wound on drum.</p> <p>If hose assembly shows evidence of leakage, loose connections, dry rot or other visible damage.</p>

Table 2-1. Operator Preventive Maintenance Checks and Services for Fire Suppression Equipment Set - continued

Item No	Interval	Location	Procedure	Not Fully Mission Capable If:
		Item To Be Check/Service		
14	Before	Roller Assembly	Check that roller assembly is in place, secure and free of binding or rust.	
15	Before	Hose Reel	Check that hose reel is secure, free of rust, and drum turns freely with rewind brake released.	Drum does not turn freely.
16	Before	Rewind Brake	Check Rewind brake to be sure it is free of rust and holds drum stationary when applied and does not bind drum when released.	Rewind brake prevents drum from turning freely when released.
17	Before	Lift Bar	Check that lift bar is free of rust, in place, and secure.	
18	Before	Dry Chemical Tank	<p>WARNING</p> <p>Cap must not be removed until tank pressure has been relieved. Severe injury can result if cap is removed while tank is pressurized.</p> <p>Check for obstruction in cap vent holes.</p> <p>Check quantity of dry chemical per paragraph 2-9 and 2-10.</p> <p>Check that cap is in place and that tank is free of rust and in good condition.</p>	<p>Cap vent holes obstructed.</p> <p>Dry chemical supply low.</p> <p>Cap missing or tank damaged.</p>

Item No	Interval	Location	Procedure	Not Fully Mission Capable If:
		Item To Be Check/Service		
19	Before	AFFF Tank	<p>WARNING</p> <p>Cap must not be removed until tank pressure has been relieved. Severe injury can result if cap is removed while tank is pressurized</p> <p>Check for obstruction in cap vent holes.</p> <p>a. Normal operation:</p> <p>Check quantity of foam liquid solution per paragraph 2-9 and 2-10</p> <p>Check that cap is in place and that tank is free of rust and in good condition.</p> <p>b. Cold weather operation:</p> <p>Check that foam liquid solution is not frozen.</p> <p>Check quantity of foam liquid solution per paragraph 2-9 and 2-14.</p> <p>Check that cap is in place and that tank is free of rust and in good condition.</p>	<p>Cap vent holes obstructed.</p> <p>Foam liquid solution low.</p> <p>Cap missing or tank damaged.</p> <p>Foam liquid solution frozen.</p> <p>Foam liquid solution low.</p> <p>Cap missing or tank damaged.</p>
20	Before	AFFF Tank Heaters	<p>Check that power cord is connected to power source at temperatures below 400 F (4 °C).</p>	<p>Foam liquid solution freezes.</p>
21	Before	Skid Frame	<p>Check that skid frame is free of rust, bends, broken welds, and missing or damaged mounting hardware.</p>	
22	Before	Trailer	<p>Check that trailer is free of rust, bends, or broken welds. Check for missing or damaged shackles, safety chains, lunette eye pintle, axle, springs, or hardware.</p>	<p>Trailer damage that would interfere with positioning equipment.</p>

Table 2-1. Operator Preventive Maintenance Checks and Services for Fire Suppression Equipment Set - continued

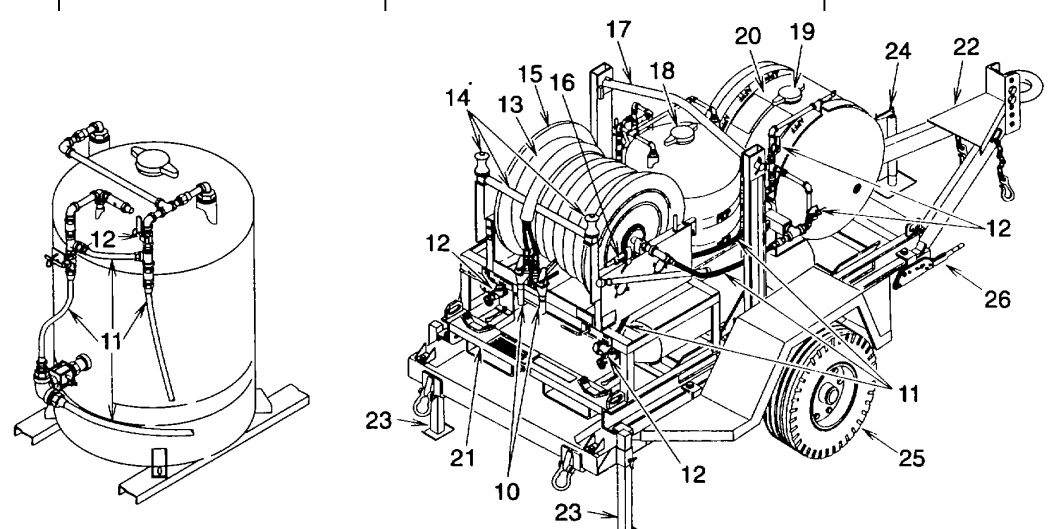
Item No	Interval	Location	Procedure	Not Fully Mission Capable If:
		Item To Be Check/Service		
23	Before	Rear Jack Stands	Check that rear jack stands are free of rust and in place. Check that handles and feet are not damaged or missing.	Damage that would interfere with positioning equipment or missing.
24	Before	Jack	Check that jack is free of rust, in place, and operates properly. Check that pin and chain and foot is not damaged or missing.	Damage that would interfere with positioning equipment or missing.
25	Before	Tires & Wheels	Check that tires are inflated and show no evidence of dry rot or excessive wear. Check that wheels are free of rust and damage. Check that nuts and studs are not damaged or missing.	Damage that would interfere with positioning equipment or missing.
26	Before	Parking Brakes	Check that parking brakes prevent wheels from turning when applied and wheels turn freely when released	

Item No	Interval	Location	Procedure	Not Fully Mission Capable If:
		Item To Be Check/Service		
28	Before	Hose Assembly	<p>Check that fire hose nozzle valve levers squeeze smoothly with no binding. Notify your supervisor if any gas escapes.</p> <p>Be sure fire hose nozzle is secure on nozzle bracket. See paragraph 2-10.</p> <p>Check that hose assembly is evenly wound on drum.</p> <p>Check visible portion of hose assembly to see if It Is tight and in good condition with no evidence of leaking or dry rot</p>	<p>Valve lever binds or is difficult to operate.</p> <p>Hose assembly not evenly wound on drum.</p> <p>If hose assembly shows evidence of leakage, loose connections, dry rot, or other visible damage.</p>
29	Before	Hose Assemblies	<p>Check that hose assemblies are tight and in good condition with no evidence of leaking or dry rot. visible damage.</p>	<p>If any hose assembly shows evidence of leakage, loose connections, dry rot, or other</p>
30	Before	Hose Reel	<p>Check that hose reel Is secure, free of rust, and drum turns freely with rewind brake released.</p>	<p>Drum does not turn freely.</p>
31	Before	Rewind Brake	<p>Check Rewind brake to be sure It is free of rust and holds drum stationary when applied and does not bind drum when released.</p>	<p>Rewind brake prevents drum from turning freely when released.</p>
32	Before	Cart	<p>Check that cart and wheels are free of rust and evidence of cracking. Check for missing or damaged tires. Check wheels for binding when turned.</p>	<p>Cart damage that would interfere with positioning equipment.</p>
33	After	Fire Suppression Equipment Set	<p>Thoroughly clean with water and mild soap. Dry thoroughly.</p>	

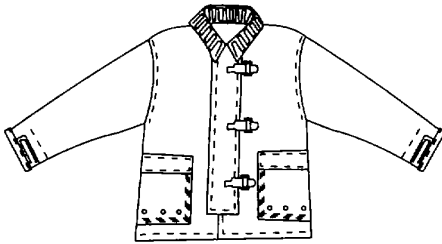
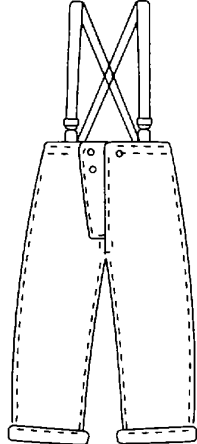
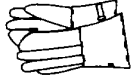
Item No	Interval	Location	Procedure	Not Fully Mission Capable If:
		Item To Be Check/Service		
34	After	   Coats, Trousers, Gloves	<ol style="list-style-type: none"> a. Clean with water and mild soap. Air dry thoroughly. b. Check that one each or pair is available per crew member. c. Inspect for tears, broken or missing fastening devices, flaking aluminum coating, mold, or mildew. <p style="text-align: center;">WARNING</p> <p>Clothing items must be kept dry. Steam produced by high heat can cause severe burns.</p> <ol style="list-style-type: none"> d. Liners should be dry and in place. 	Protective clothing missing, damaged, or damp.

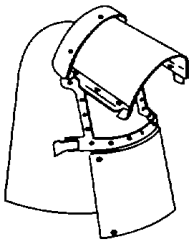
Item No	Interval	Location	Procedure	Not Fully Mission Capable If:
		Item To Be Check/Service		
35	After	Hoods	 <p>a Clean with water and mild soap. Hoods missing, damaged, or damp. Air dry thoroughly.</p> <p>b. Check that one is available per crew member.</p> <p>c. Inspect for tears, flaking aluminum coating, mold, or mildew.</p> <p>WARNING Clothing items must be kept dry. Steam produced by high heat can cause severe burns.</p> <p>d. Hoods should be dry.</p> <p>e. Check that face shield is not broken or cracked, missing, melted, or visually distorted.</p> <p>f. Check that internal helmet functions properly and is not missing or damaged and that the chin strap is not missing or damaged.</p>	

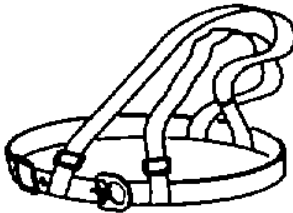
Item No	Interval	Location	Procedure	Not Fully Mission Capable If:
		Item To Be Check/Service		
36	After	Boots	 <p>a. Clean with water and mild soap. Air dry thoroughly.</p> <p>b. Check that one pair is available per crew member.</p> <p>c. Inspect for holes, tears, flaking aluminum coating, evidence of melting, mold, or mildew.</p> <p style="text-align: center;">WARNING</p> <p>Clothing Items must be kept dry. Steam produced by high heat can cause severe burns.</p> <p>d. Boots should be dry.</p>	Boots missing, damaged, or damp.
37	After	Harness	 <p>Check that harness is not missing or damaged.</p>	

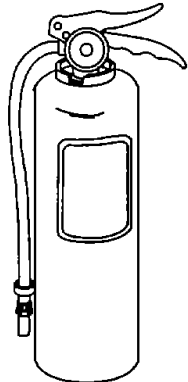
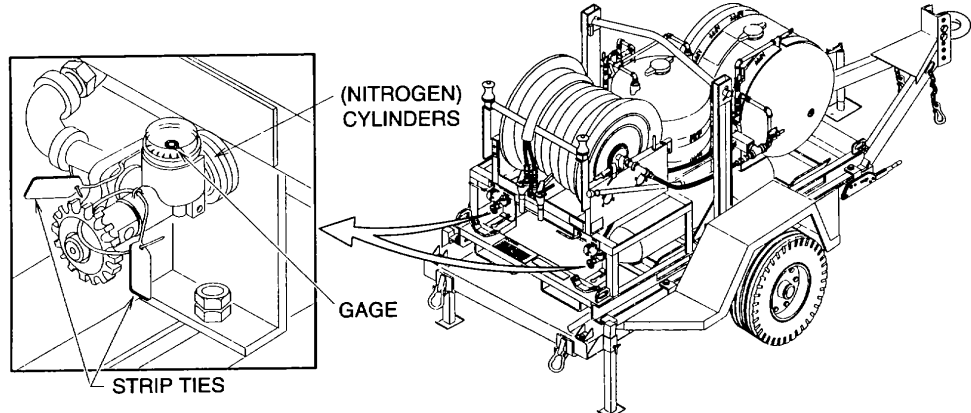
Item No	Interval	Location	Procedure	Not Fully Mission Capable If:
		Item To Be Check/Service		
38	After	Hand Held Fire Extinguishers	 <p>a. Check for dents, tears, damaged or missing hose, and broken or missing handle. b. Check if fully charged.</p>	
39	After	Cylinders	 <p>Check that two cylinders are installed. Check that strip ties are in place. Check if gage lens is cracked, broken, or missing.</p>	<p>Not installed.</p> <p>Strip ties broken or missing. Gage lens broken or missing.</p>

Item No	Interval	Location	Procedure	Not Fully Mission Capable If:
		Item To Be Check/Service		
39	After	Cylinders - continued	<p>a. Normal operation</p> <p>Check that gage indicates 1750 psi (12075 kPa) or more. Notify supervisor if below 1750 psi. (12075 kPa)</p> <p>b. Cold weather operation:</p> <p>Check that gage indicates pressures at or above those listed below for current temperature.</p> <p><u>COLD WEATHER RANGE</u></p> <p>-40=1575 psi (10868 kPa) -20=1650 psi (11385 kPa) 0=1725 psi (11903 kPa) 10=1750 psi (12075 kPa)</p>	<p>Cylinder pressure is below 1750 psi. (12075 kPa) for normal operation.</p> <p>Cylinder pressure is below cold weather operation ranges</p>

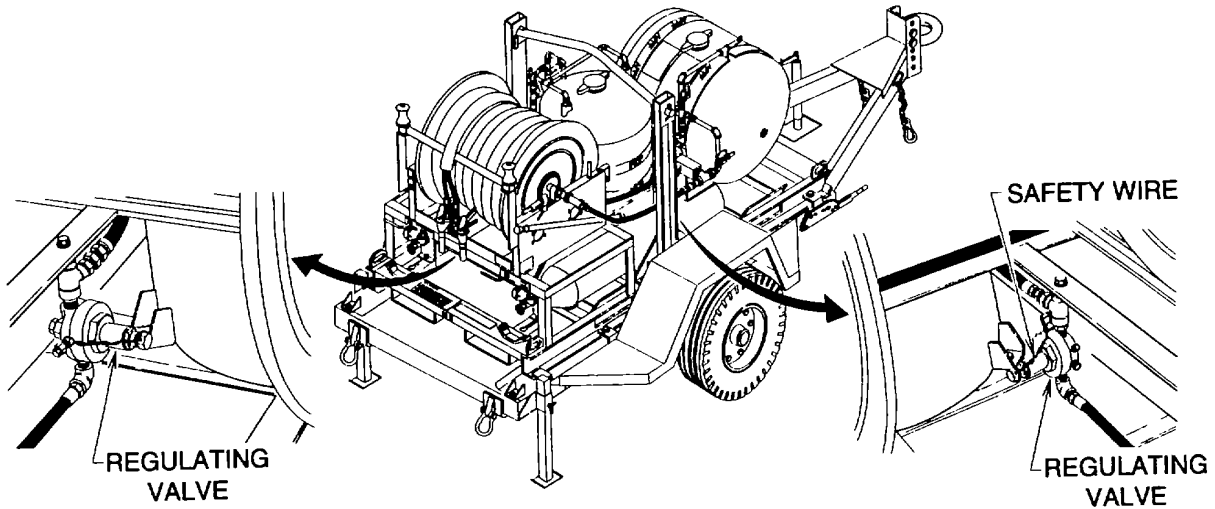

40	After	Regulating valves	Check for any visible damage and broken or missing safety wire	Visibly damaged or safety wire missing.
41	After	Name and Instruction Plates	Check that name and instruction plates are legible and in place. See figure 2-23	

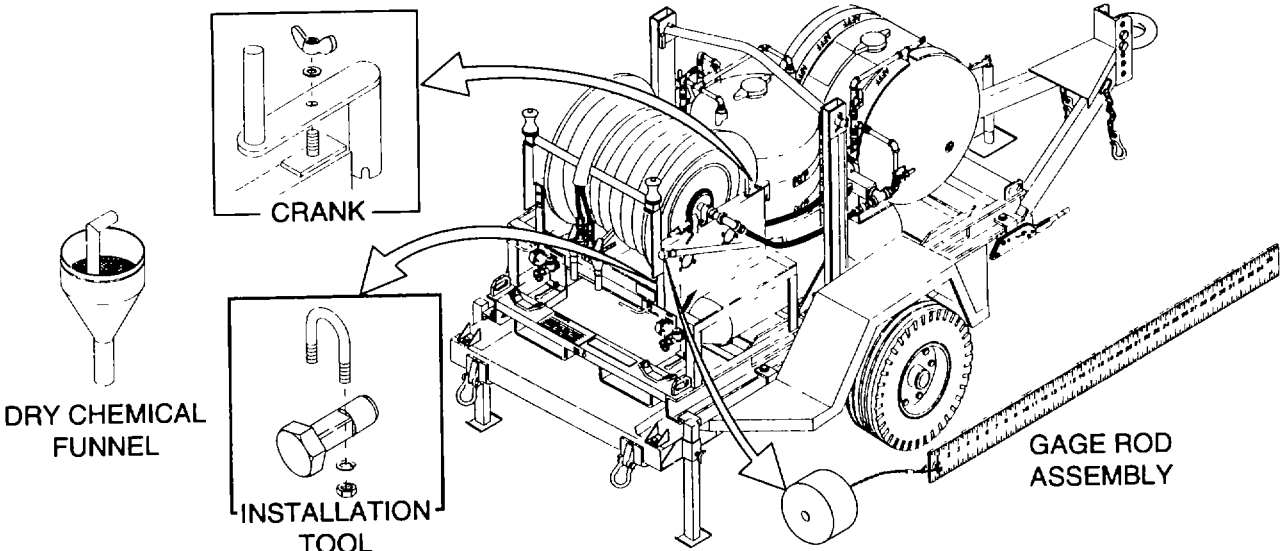
Item No	Interval	Location	Procedure	Not Fully Mission Capable If:
		Item To Be Check/Service		
42	After	Accessories	 <p>Check that the following accessories are available, in good condition, and free of rust.</p> <ol style="list-style-type: none"> 1) Dry Chemical Funnel 2) Crank 3) Gage Rod Assembly 4) Installation Tool 	

Item No	Interval	Location	Procedure	Not Fully Mission Capable If:
		Item To Be Check/Service		
43	After	Fire Hose Nozzle	<p>Check for obstruction in fire hose nozzle outlet.</p> <p>Check that fire hose nozzle valve levers squeeze smoothly with no binding. Notify your supervisor if any gas escapes.</p> <p>Be sure fire hose nozzle is secure on nozzle bracket. See paragraph 2-10.</p>	<p>Fire hose nozzle is obstructed.</p> <p>Valve lever binds or is difficult to operate.</p>
44	After	Hose Assemblies	<p>Check that hose assemblies are tight and in good condition with no evidence of leaking or dry rot visible damage.</p>	<p>If any hose assembly shows evidence of leakage, loose connections, dry rot, or other</p>
45	After	Valves and Piping	<p>Check for evidence of leaking or visible damage and if strip ties are missing.</p>	<p>Damaged, leaking, or strip ties missing.</p>

Item No	Interval	Location	Procedure	Not Fully Mission Capable If:
		Item To Be Check/Service		
46	After	Hose Assembly	<p>Unwind hose assembly, if It was used, and clean with water and mild soap. Dry thoroughly.</p> <p>Check visible portion of hose assembly to see if it is tight and in good condition with no evidence of leaking or dry rot</p> <p>If unwound from drum, rewind back onto drum.</p> <p>Check that hose assembly is evenly wound on drum.</p>	<p>If hose assembly shows evidence of leakage, loose connections, dry rot, or other visible damage.</p> <p>Hose assembly not evenly wound on drum.</p>
47	After	Roller Assembly	<p>Check that roller assembly is in place, secure and free of binding or rust.</p>	
48	After	Hose Reel	<p>Check that hose reel is secure, free of rust, and drum turns freely with rewind brake released.</p>	<p>Drum does not turn freely.</p>
49	After	Rewind Brake	<p>Check Rewind brake to be sure it is free of rust and holds drum stationary when applied and does not bind drum when released.</p>	<p>Rewind brake prevents drum from turning freely when released.</p>
50	After	Lift Bar	<p>Check that lift bar is free of rust, In place, and secure.</p>	
51	After	Dry Chemical Tank	<p>WARNING</p> <p>Cap must not be removed until tank pressure has been relieved. Severe injury can result if cap is removed while tank is pressurized.</p> <p>Check for obstruction in cap vent holes.</p> <p>Check quantity of dry chemical per paragraph 2-9 and 2-10.</p> <p>Check that cap is In place and that tank is free of rust and in good condition.</p>	<p>Cap vent holes obstructed.</p> <p>Dry chemical supply low.</p> <p>Cap missing or tank damaged.</p>

Item No	Interval	Location	Procedure	Not Fully Mission Capable If:
		Item To Be Check/Service		
52	After	AFFF Tank	<p>WARNING</p> <p>Cap must not be removed until tank pressure has been relieved. Severe injury can result if cap is removed while tank is pressurized</p> <p>Check for obstruction in cap vent holes.</p> <p>a. Normal operation: Check quantity of foam liquid solution per paragraph 2-9 and 2-10.</p> <p>Check that cap is in place and that tank is free of rust and in good condition.</p> <p>b. Cold weather operation: Check if foam liquid solution is frozen.</p> <p>Check quantity of foam liquid solution per paragraph 2-9 and 2-10.</p> <p>Check that cap is in place and that tank is free of rust and in good condition.</p>	<p>Cap vent holes obstructed.</p> <p>Foam liquid solution low.</p> <p>Cap missing or tank damaged</p> <p>Foam liquid solution frozen.</p> <p>Foam liquid solution low.</p> <p>Cap missing or tank damaged.</p>
53	After	AFFF Tank Heaters	<p>Check that power cord is connected to power source at temperatures below 40° F (4 °C).</p>	<p>Foam liquid solution freezes.</p>
54	After	Skid Frame	<p>Check that skid frame is free of rust, bends, broken welds, and missing or damaged mounting hardware.</p>	
55	After	Trailer	<p>Check that trailer is free of rust, bends, or broken welds. Check for missing or damaged shackles, safety chains, lunette eye pintle, axle, springs, or hardware.</p>	<p>Trailer damage that would interfere with positioning equipment.</p>

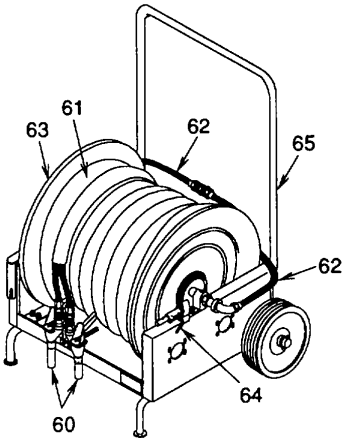
Item No	Interval	Location	Procedure	Not Fully Mission Capable If:
		Item To Be Check/Service		
56	After	Rear Jack Stands	Check that rear jack stands are free of rust and in place. Check that handles and feet are not damaged or missing.	Damage that would interfere with positioning equipment or missing.
57	After	Jack	Check that jack is free of rust, in place, and operates properly. Check that pin and chain and foot is not damaged or missing.	Damage that would interfere with positioning equipment or missing.
58	After	Tires & Wheels	Check that tires are inflated and show no evidence of dry rot or excessive wear. Check that wheels are free of rust and damage. Check that nuts and studs are not damaged or missing.	Damage that would interfere with positioning equipment or missing.
59	After	Parking Brakes	Check that parking brakes prevent wheels from turning when applied and wheels turn freely when released.	
60	After	Fire Hose Nozzle	 <p>Check for obstruction in fire hose nozzle outlet.</p> <p>Check that fire hose nozzle valve levers squeeze smoothly with no binding. Notify your supervisor if any gas escapes.</p> <p>Be sure fire hose nozzle is secure on nozzle bracket See paragraph 2-10</p>	<p>Fire hose nozzle is obstructed.</p> <p>Valve lever binds or is difficult to operate.</p>

Item No	Interval	Location	Procedure	Not Fully Mission Capable If:
		Item To Be Check/Service		
61	After	Hose Assembly	<p>Unwind hose assembly, if it was used, and clean with water and mild soap. Dry thoroughly.</p> <p>Check visible portion of hose assembly to see if it is tight and in good condition with no evidence of leaking or dry rot.</p> <p>If unwound from drum, rewind back onto drum.</p> <p>Check that hose assembly is evenly wound on drum.</p>	<p>If hose assembly shows evidence of leakage, loose connections, dry rot, or other visible damage.</p> <p>Hose assembly not evenly wound on drum.</p>
62	After	Hose Assemblies	<p>Check that hose assemblies are tight and in good condition with no evidence of leaking or dry rot visible damage.</p>	<p>If any hose assembly shows evidence of leakage, loose connections, dry rot, or other</p>
63	After	Hose Reel	<p>Check that hose reel is secure, free of rust, and drum turns freely with rewind brake released.</p>	<p>Drum does not turn freely.</p>
64	After	Rewind Brake	<p>Check Rewind brake to be sure it is free of rust and holds drum stationary when applied and does not bind drum when released.</p>	<p>Rewind brake prevents drum from turning freely when released.</p>
65	After	Cart	<p>Check that cart and wheels are free of rust and evidence of cracking.</p> <p>Check for missing or damaged tires.</p> <p>Check wheels for binding when turned.</p>	<p>Cart damage that would interfere with positioning equipment.</p>

Section III. OPERATION UNDER USUAL CONDITIONS

2-9 ASSEMBLY AND PREPARATION FOR USE.

a. Assembly.

CAUTION

Always fill the dry chemical tank first and ensure the dry chemical funnel is completely dry prior to use so no water is introduced into the tank. Any moisture in the dry chemical can cause it to clog due to caking.

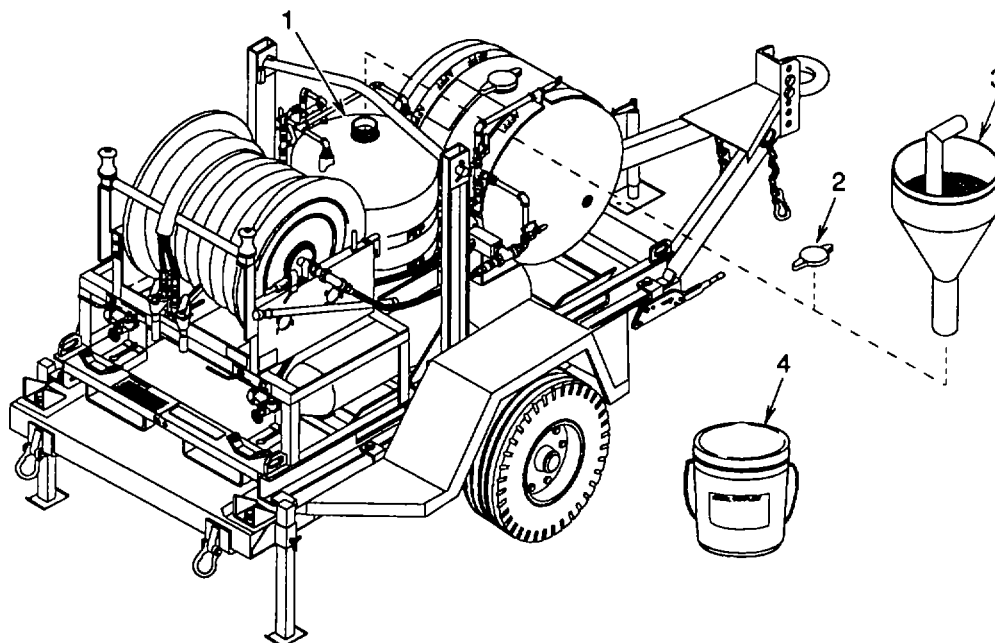

Figure 2-6. Filling Dry Chemical Tank

(1) The dry chemical tank (1) is filled with 450 pounds (204 kilograms) dry chemical prior to shipment. Check the dry chemical for "caking".

(2) Remove the cap (2) from the dry chemical tank (1). Stir the dry chemical to break up any lumps and loosen it if it has packed from shipping.

(3) Check the dry chemical for hard lumps that would prevent the system from operating. If lumps are found, remove one and drop it from a height of four inches (10 centimeters) onto a hard surface. If the lump completely breaks apart, the dry chemical is only packed from settling and is in satisfactory condition. If the lump does not break apart completely, caking is present and the dry chemical must be replaced.

2-9. ASSEMBLY AND PREPARATION FOR USE. - continued

NOTE

When refilling dry chemical tank be sure no water is introduced into the tank. If the dry chemical funnel has been used to fill the AFFF tank, ensure that it is completely dry prior to using it with the dry chemical.

(4) Using dry chemical funnel (3), top off or refill the dry chemical tank with dry chemical (4) if needed per table 2-2.

Table 2-2. Dry Chemical Tank Refill Table

Distance from top of fill collar to surface of dry chemical		Amount of dry chemical to add.
<i>Fresh</i>	<i>Settled (Packed)</i>	
Inches (Centimeters)	Inches (Centimeters)	Pounds (Kilograms)
4.5 (11.4)	8.5 (21.6)	None
8.5 (21.6)	11.5 (29.2)	50 (23)
11.5 (29.2)	14 (36)	100 (45)
14.5 (36.8)	17 (43)	150 (68)
18 (46)	20 (51)	200 (91)
21.5 (54.6)	23 (58)	250 (113)
24.5 (62.2)	25.5 (64.8)	300 (136)
28 (71)	28.5 (72.4)	350 (159)
31 (79)	31.5 (80.0)	400(181)
36 (91)	36 (91)	450 (204)

(5) Replace cap (2) and tighten hand tight.

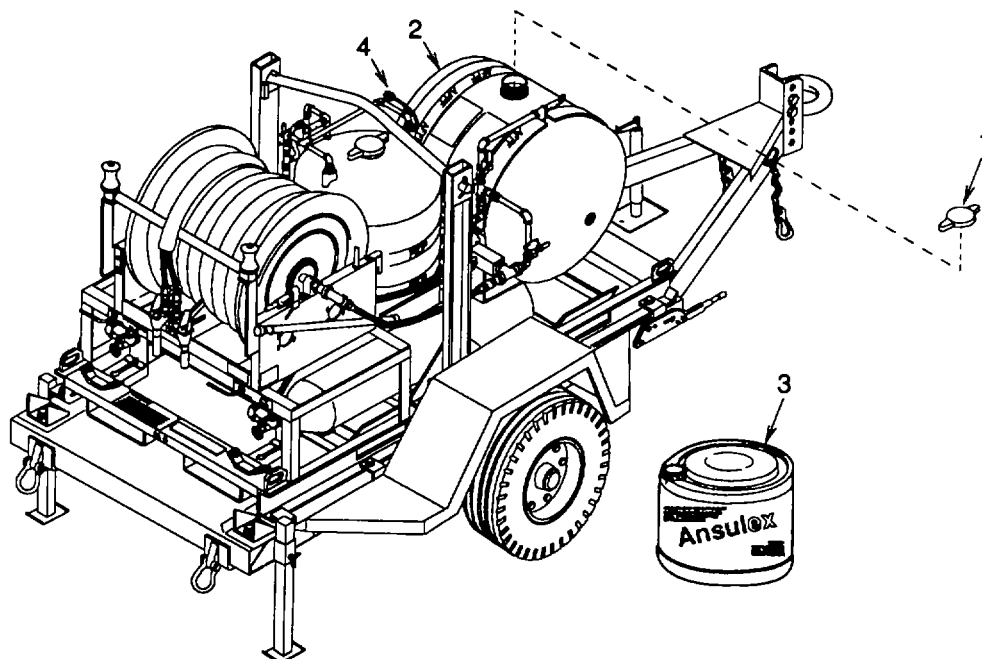

Figure 2-7. Filling AFFF Tank

NOTE

The foam liquid and water mixture is subject to freezing. If freezing weather conditions exist do not service the AFFF tank until the power cord is connected to a power source.

- (6) Remove the cap (1) from the AFFF tank (2).

2-9 ASSEMBLY AND PREPARATION FOR USE. - continued

CAUTION

Be careful not to damage the AFFF tank lining with metal hose ends or connections. The lining can be scratched or scored resulting in corrosion of the AFFF tank

NOTE

- Foam liquid will freeze, but the plastic container(s) used for shipment will expand safely with the ice. The foam liquid can be used after it thaws.
- Foam liquid must be disposed of in compliance with local, state, and federal regulations. Rinse any spill thoroughly with water as the foam liquid is slippery.
- The foam liquid poses no direct hazard, however it should be disposed of in limited quantities at a time to avoid nuisance foaming in sewer or waterway

(7) When refilling the AFFF tank, insert a hose against the bottom of the tank and add water to within nine inches (23 cm) of the fill collar top, pour in the required amount of foam liquid per table 2-3, then fill the AFFF tank with water until the foam liquid and water mixture is 4.5 inches (11.4 centimeters) from top of fill collar. No further mixing of the solution is required after the initial filling

Table 2-3. AFFF Tank Refill Table

Distance from top of fill collar to surface of foam liquid and water mixture. Inches (Centimeters)	Amount of foam liquid to add. Gallons (Liters)
4.5 (11.4)	None
7 (18)	0.5 (1.9)
9.25 (23.50)	1 (4)
11.5 (29.2)	1.5 (5.7)
13.5 (34.3)	2 (8)
15.5 (39.4)	2.5 (9.5)
17 (43.2)	3 (11)
18.5 (47.0)	3.5 (13.3)
20.5 (52.1)	4 (15)
22.5 (57.2)	4.5 (17.0)
24.75 (62.87)	5 (19)
27 (68.6)	5.5 (20.8)
31.75 (80.65)	6 (23)

- (8) Replace fill cap (1) and tighten hand tight
- (9) If freezing weather exists, or is expected, connect the AFFF tank heater power cord (4) to power source.

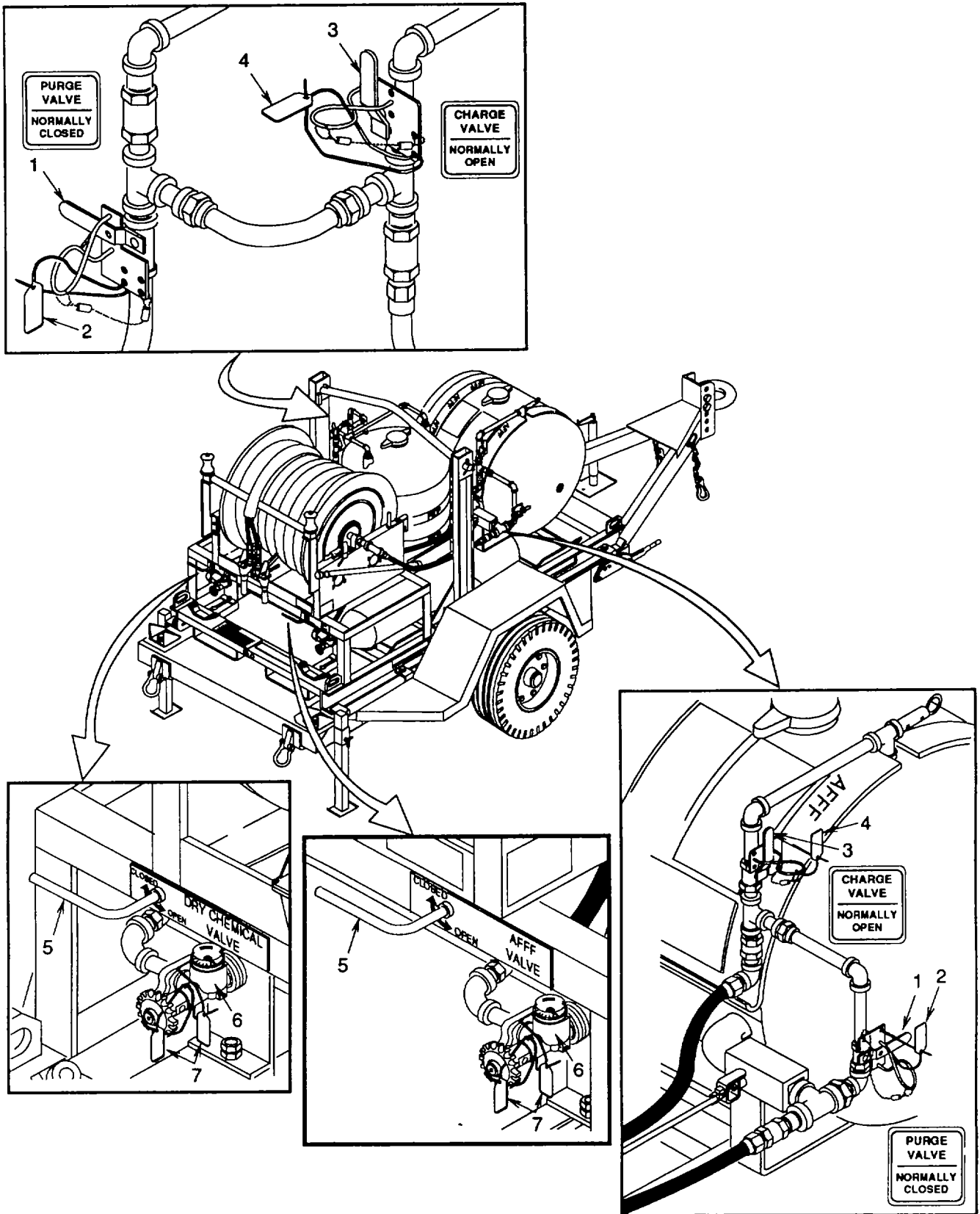

Figure 2-8. Ready State Valve Position

2-9. ASSEMBLY AND PREPARATION FOR USE. - continued

- (10) Check that the system valves are In the proper ready state position.
 - (a) Both purge ball valves (1) should be CLOSED. Strip ties (2) In place
 - (b) Both charge ball valves (3) should be OPEN. Strip ties (4) In place
 - (c) Valve rods (5) should be CLOSED.
 - (d) Both nitrogen cylinder valves (6) have two each strip ties (7) in place

b. Installation.

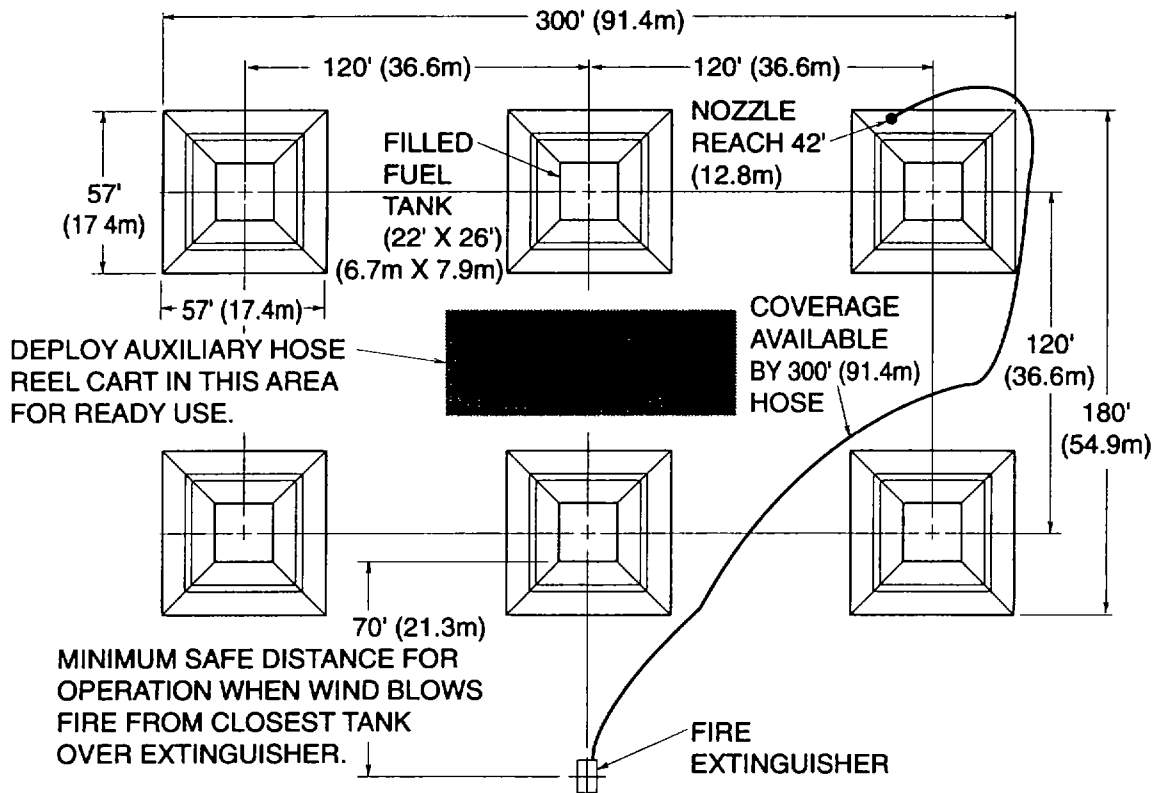

Figure 2-9. Location of Trailer Mounted Fire Extinguisher and Auxiliary Hose Reel Cart

- (1) Site selection.

NOTE

Figure 2-9 is a typical installation configuration. See system manual for additional configurations.

- (a) The trailer mounted extinguisher assembly can be used as a portable unit being towed or set-up for stationary use. The unit does not need to be precisely leveled. Refer to figure 2-8 for recommended locations with respect to bulk fuel tanks and auxiliary mobile hose reel cart to provide safety of operation and maximum effectiveness

(b) The trailer mounted extinguisher assembly is self-contained and requires minimal space. Room for effective operation and maintenance is all that is required. A source of electrical power (120/240 volt, 1 phase, 60 hertz, AC) for the AFFF tank heater and water to recharge the AFFF tank is the only external support needed from the using organization.

(c) The fire suppression equipment set must be properly set up for stationary use.

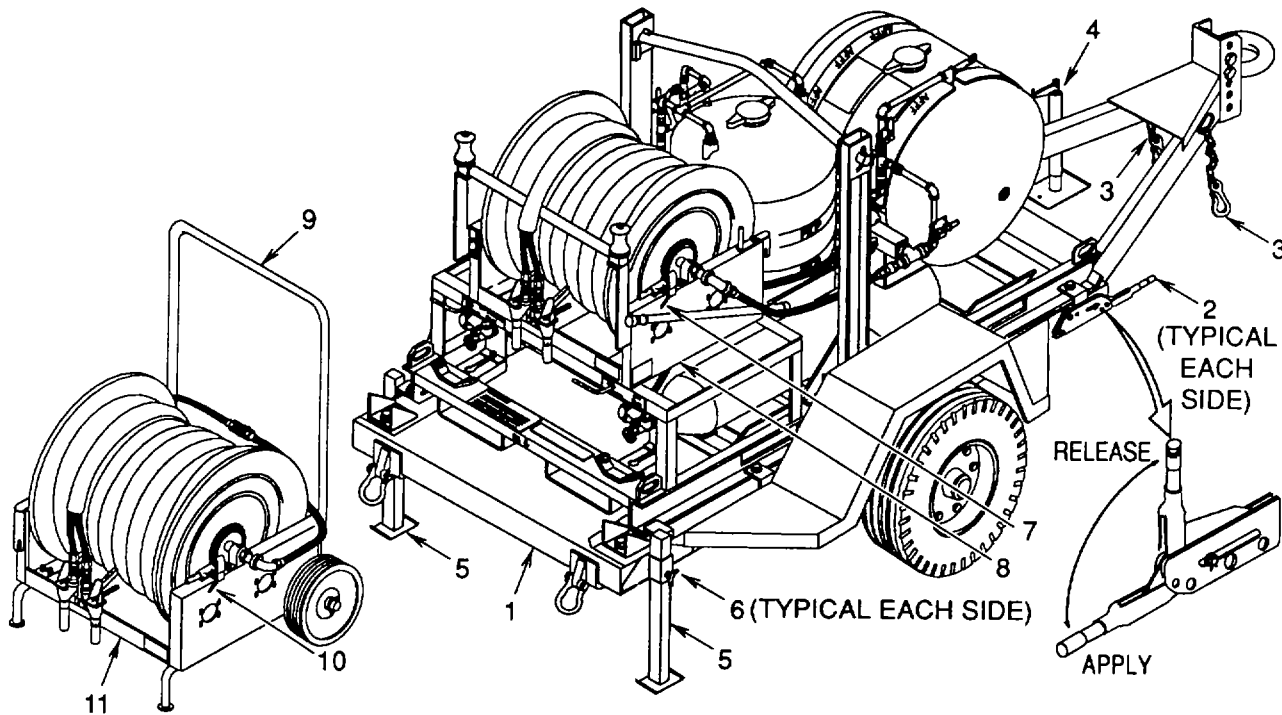

Figure 2-10. Equipment Setup

(2) Equipment setup.

WARNING

The equipment is made of metal. Wear gloves when operating or servicing as surfaces can become very hot if unprotected from the sun in extremely hot climates.

(a) Remove the trailer mounted extinguisher assembly (1) from the towing vehicle.

1 Apply both parking brakes (2).

2 Disconnect safety chains (3).

3 Position the jack (4) from the towing (horizontal) position to the support (vertical) position and use to lift the front of the trailer mounted extinguisher assembly (1) off the towing vehicle. When loose, move the vehicle away.

4 Lower the jack (4) enough to allow the two rear jack stands (5) to drop to the extended position. Loosen the two handles (6) and lower each rear jack stand. Tighten handle into upper hole of each jack stand.

2-9. ASSEMBLY AND PREPARATION FOR USE. - continued

5 Raise jack (4) to support and stabilize the trailer mounted extinguisher assembly (1).

6 Release rewind brake (7) on the hose reel (8).

(b) Position the auxiliary mobile hose reel cart (9) no more than 125 feet (38 meters) from trailer mounted extinguisher assembly (1) with the cart handle toward the back of the trailer mounted extinguisher assembly. Release rewind brake (10) on the hose reel (11).

WARNINGS

Clothing items must be kept dry. Steam produced by high heat can cause severe burns.

c. Initial Checks.

Perform your before PMCS.

2-10 OPERATING PROCEDURES.

The instructions in this paragraph are for information and guidance of the personnel responsible for the operation of the fire suppression equipment set. It is essential that the operators and all assisting personnel know how to successfully extinguish various fires. Refer to TM 5-315 for additional fire fighting techniques. The fire suppression equipment set, as emergency equipment, is always maintained in an operational ready status.

WARNING

Special heat resistant clothing, including hood, coat, pants, gloves and boots, must be worn while fighting any large scale petroleum fire. Injury to personnel can result if not properly protected. Burning hydrocarbons produce toxic smoke. Avoid smoke to prevent personal injury. A minimum of two and preferably three personnel are required to operate the fire suppression equipment trailer set. Injury can result from moving hoses when in operation.

a. Equipment application.

NOTE

The fire suppression equipment trailer set holds 150 feet (46 meters) of twin agent hose assembly and the auxiliary mobile hose reel cart carries 150 feet (46 meters) of twin agent hose assembly. Connecting the auxiliary mobile hose reel cart will give a maximum reach of 300 feet (91 meters). Flow rate with 300 feet (91 meters) of hose will be reduced.

- (1) Put on protective clothing.
- (2) Determine if the auxiliary hose reel cart is needed.
- (3) If cart is to be used proceed to step b. If not, go to step c.

- b. Operation with remote hose reel cart.

WARNING

Nitrogen valves must be closed. Injury to personnel can result if hoses are disconnected with system at operating pressure.

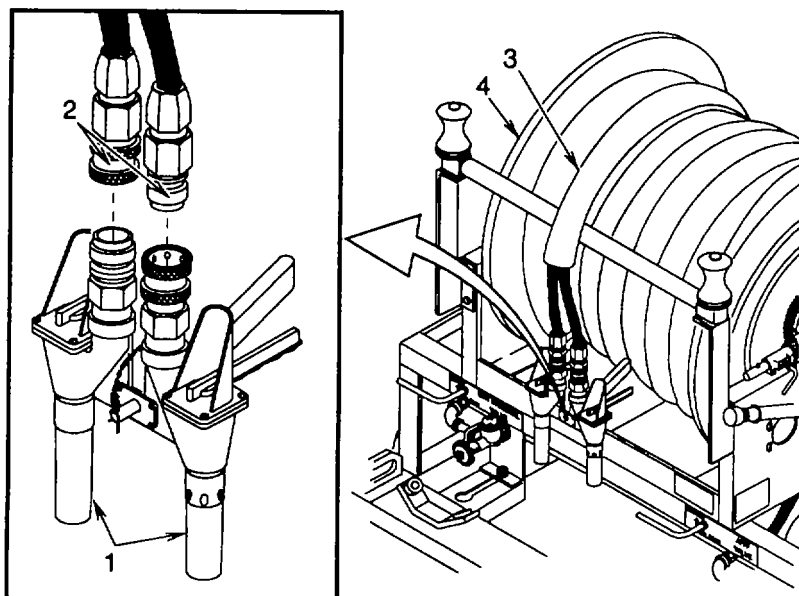

Figure 2-11. Unwind Hose Assembly From Trailer Mounted Extinguisher Assembly

2-10. OPERATING PROCEDURES - continued

- (1) Squeeze both fire hose nozzle (1) (fig. 2-11) valve levers to release any residual pressure.
- (2) Release coupling halves (2) and remove hose assembly (3) from fire hose nozzle (1)
- (3) Pull all the hose assembly (3) from drum (4).

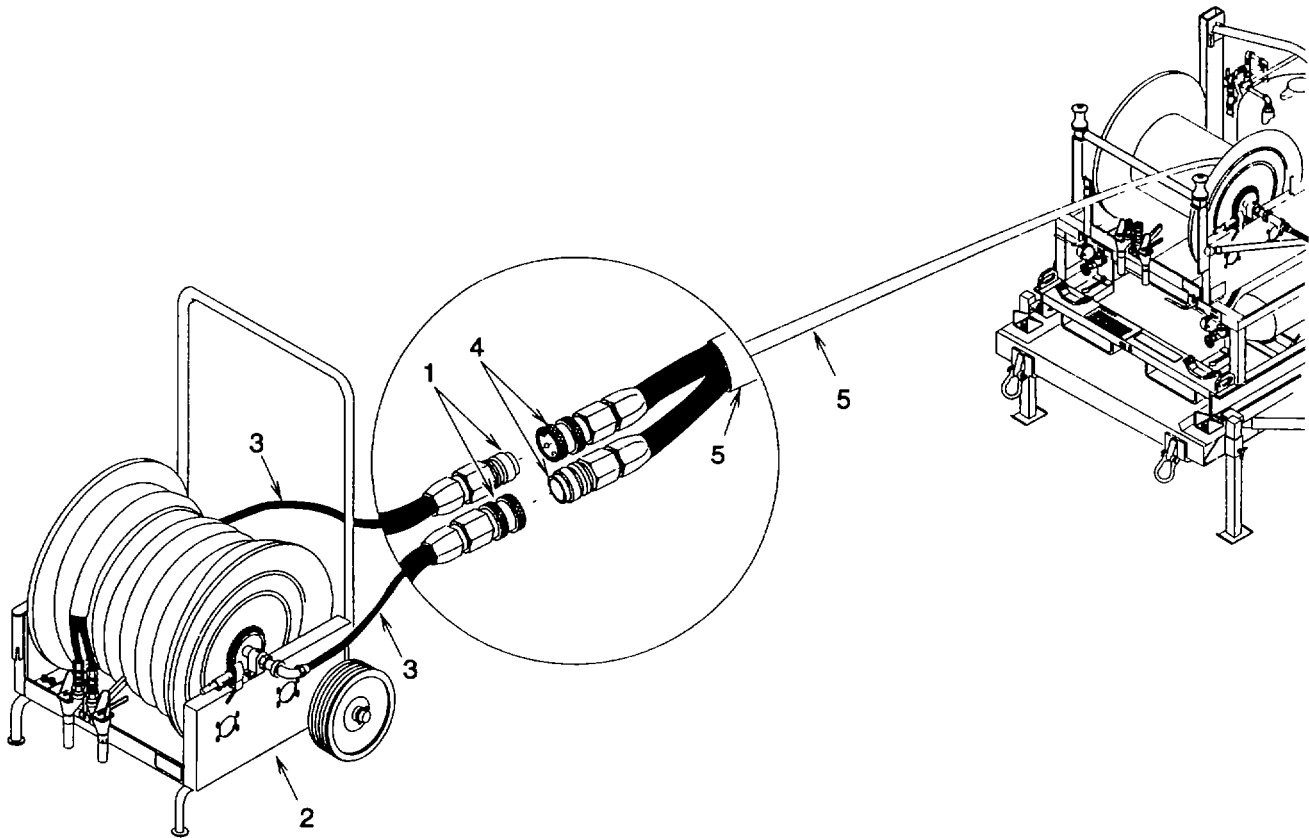

Figure 2-12. Auxiliary Mobile Hose Reel Cart Hose Connection

- (4) Release coupling halves (1) (fig. 2-12) on auxiliary mobile hose reel cart (2) and separate hose assemblies (3).
- (5) Connect coupling halves (4), from hose assembly (5), to hose assemblies (3).
- (6) Proceed to step c.

c. Operation with trailer mounted extinguisher assembly only and continued operation with auxiliary mobile hose reel cart

NOTE

If auxiliary mobile hose reel cart is needed to reach the fire, connect it to the trailer mounted extinguisher assembly per paragraph b. before opening the nitrogen cylinder valves.

Strip ties have been put on critical valves to indicate tampering with ready status settings. The strip ties will easily break when operating valves.

- (1) Break strip ties (1) (fig. 2-13).

(2) Open both nitrogen cylinder quick release valves (2) The AFFF tank will pressurize in 1-2 seconds, the dry chemical tank should pressurize within 10 seconds.

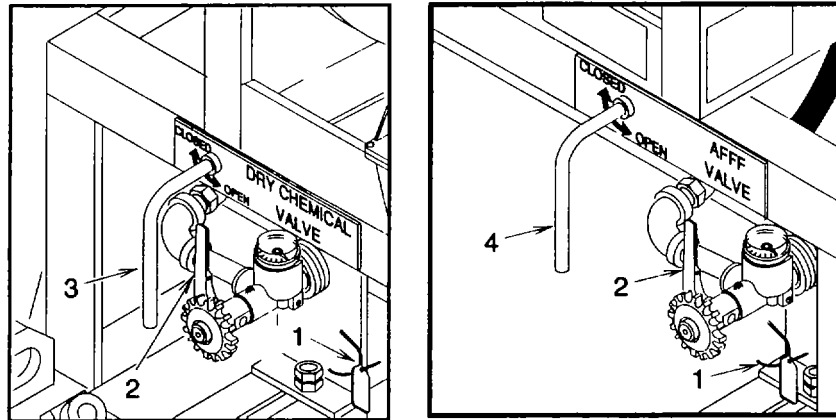

Figure 2-13. Nitrogen Cylinder Valves and Valve Rods Operational Setting

(3) Rotate the dry chemical tank ball valve rod (3) and the AFFF tank ball valve rod (4) to full open position. The system hose assemblies will pressurize up to the fire hose nozzles.

(4) Remove lock pin (1) (fig. 2-14) and fire hose nozzles (2) from nozzle bracket (3).

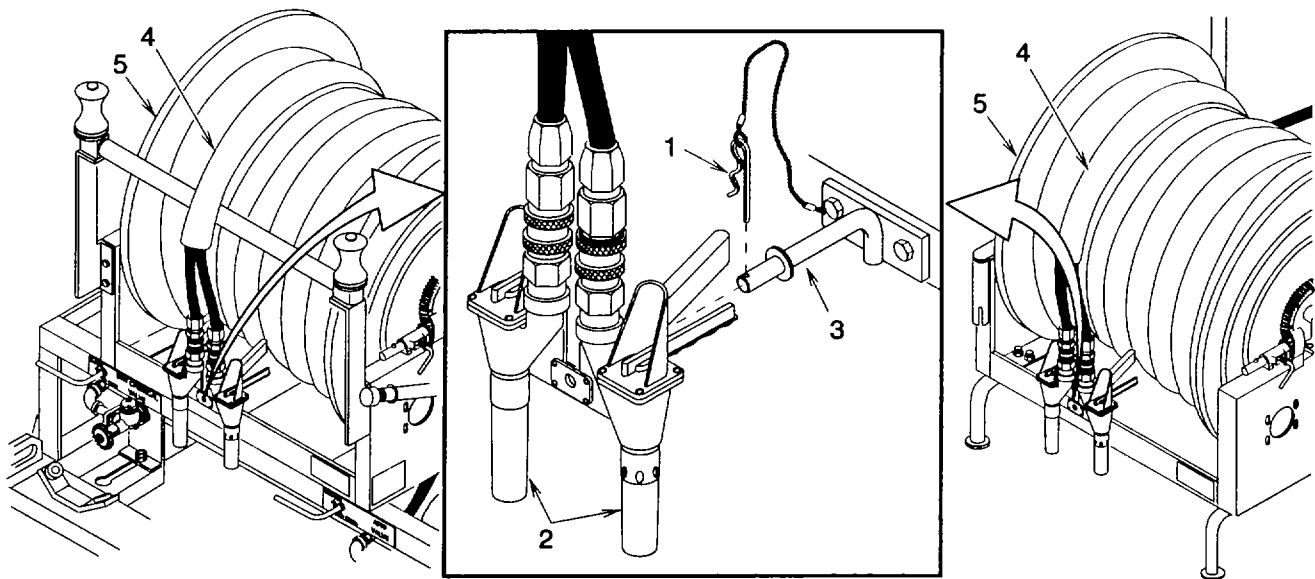

Figure 2-14. Unwind Hose Assembly from Drum

(5) Pull all the hose assembly (4) from drum (5).

2-10. OPERATING PROCEDURES - continued

WARNING

Do not enter berm, to avoid serious burns.

Do not disturb the AFFF blanket applied over a fire. Disturbing the AFFF blanket by stepping through it, spraying on it, etc. can allow hot vapors to escape that could ignite

(6) Approach the fire from upwind. Lean toward fire and aim the fire hose nozzles (2) toward the left side base of the fire. Squeeze dry chemical fire hose nozzle valve lever (right hand) and apply dry chemical by sweeping across base of fire to the right. Release dry chemical fire hose nozzle valve lever and squeeze AFFF fire hose nozzle valve lever (left hand) and apply AFFF by sweeping to the left covering dry chemical.

(7) When headway is gained on fire, continue side by side sweeping across base of fire while alternating dry chemical (right hand, sweep right) and covering with AFFF (left hand, sweep left) until fire is extinguished.

NOTE

Continuous flow of fire fighting agents can only be maintained for less than 2 minutes.

(8) When the area clears, extinguish any smoldering pockets that may re-ignite the fuel.

(9) Engineer fire fighting detachment must verify that fire is totally extinguished.

d. Returning fire suppression equipment set to operational ready (normal) or stand-by status The fire suppression equipment set must be returned to ready status Immediately after use.

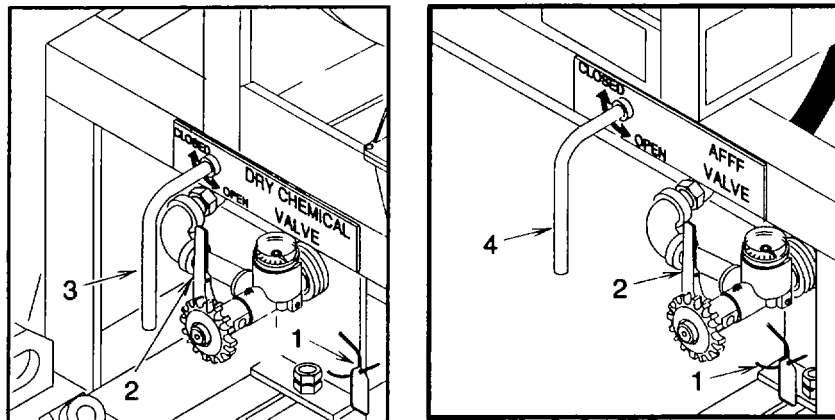

Figure 2-15. Close Chemical Agent Shut-off Valves

CAUTION

Hose assembly clean-out must take place immediately after tank has been completely or partially discharged.

- (1) Completely unwind hose assembly from drum. If auxiliary mobile hose reel cart was used, both hose assemblies must be unwound.
- (2) Close dry chemical and AFFF tank ball valve rods (1) (fig. 2-15).
- (3) Break strip ties (1) (fig. 2-16). Remove retaining clips (2) and close charge ball valves (3)
- (4) Break strip ties (4). Remove retaining clips (5) and open both purge ball valves (6)

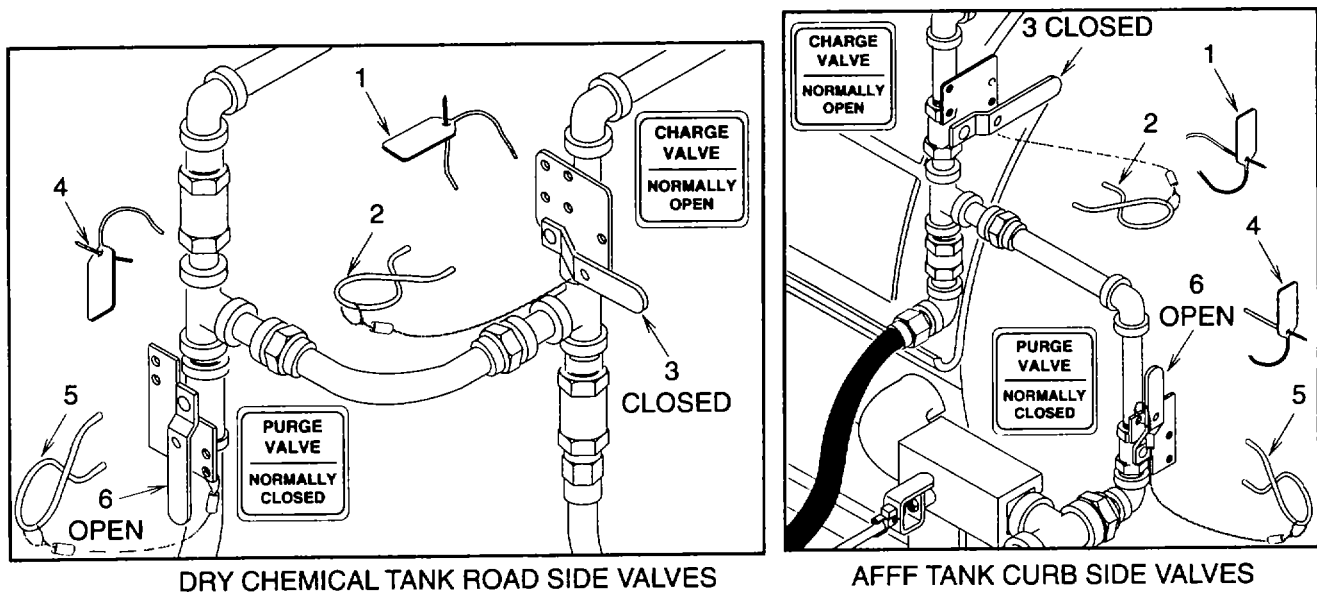

Figure 2-16. Ball Valve Settings for Clearing Hoses

2-10. OPERATING PROCEDURES. - continued

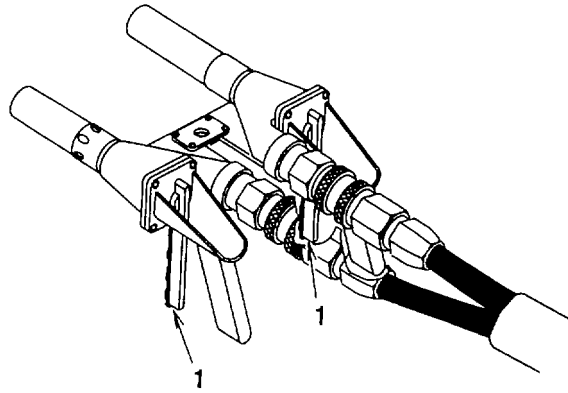

Figure 2-17. Fire Hose Nozzles

NOTE

Foam liquid must be disposed of in compliance with local, state, and federal regulations. Rinse any spill thoroughly with water as the foam liquid is slippery. The foam liquid poses no direct hazard, however it should be disposed of in limited quantities at a time to avoid nuisance foaming in sewer or waterway

(5) Slowly squeeze fire hose nozzle valve levers (1) (fig. 2-17) one at a time until each hose is cleared. The fire hose nozzle should discharge gas only for 10 seconds.

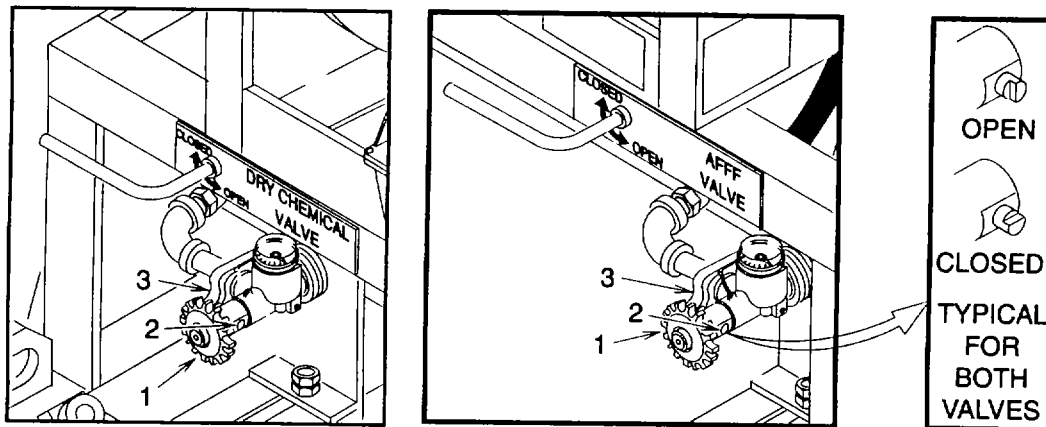

Figure 2-18. Reset Cylinder Valves to Operational Ready Condition

(7) Turn each nitrogen cylinder valve hand wheel (1) (fig. 2-18) fully counterclockwise (open). Lower quick-release lever (2). Rotate cross shaft (3) until flat is horizontal. Turn hand wheel fully clockwise (closed).

(8) Squeeze both fire hose nozzle valve levers (1) (fig. 2-17) to relieve system pressure

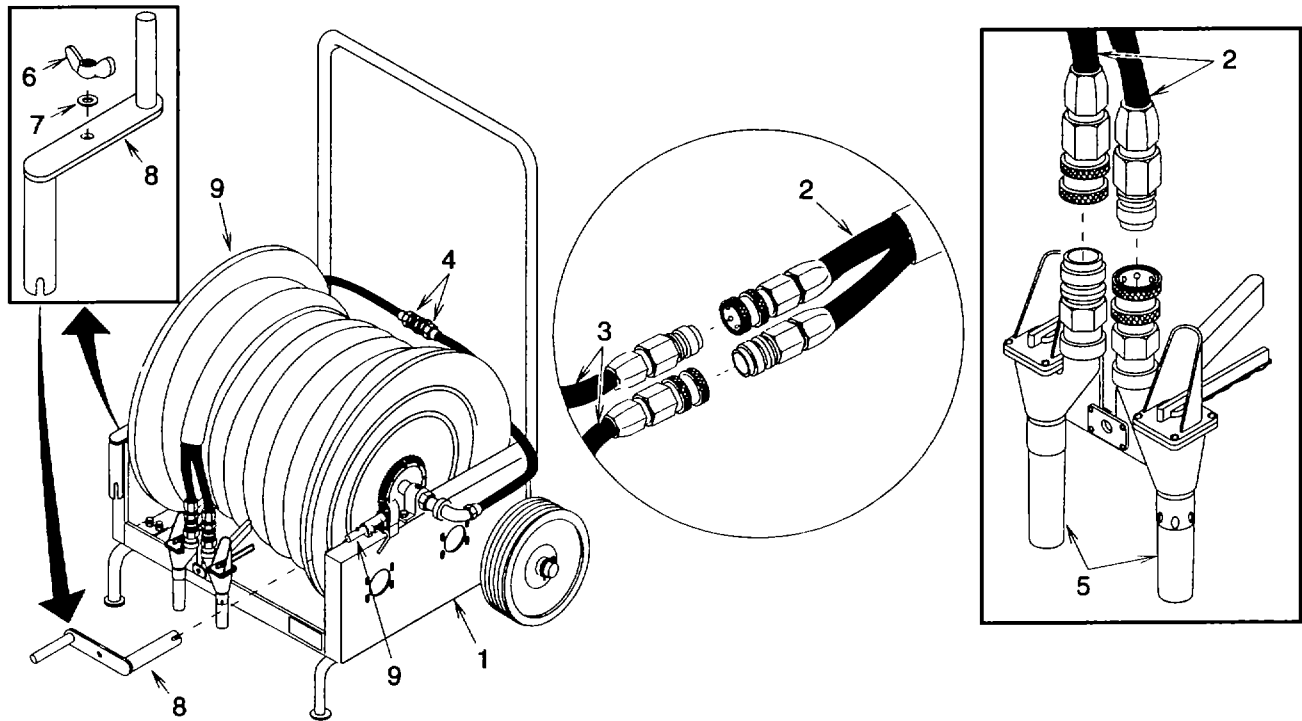

Figure 2-19. Return Auxiliary Hose Reel Cart to Ready Condition

- (9) If auxiliary mobile hose reel cart (1) (fig. 2-19) was used, disconnect the hose assembly (2) from the hose assemblies (3) Connect the hose assembly coupling halves (4) to each other.
- (10) Connect the fire hose nozzles (5) to the hose assembly (2).

NOTE

Steps (11) through (14) apply to both auxiliary mobile hose reel cart and trailer mounted extinguisher assembly.

- (11) Remove wing nut (6) and flat washer (7). Remove crank (8) from storage position and place on rewind brake shaft (9)
- (12) Using crank (8), wind hose assembly (2) onto drum (10).
- (13) Secure fire hose nozzle (1) (fig 2-20) to nozzle bracket (2) with lock pin (3).

NOTE

If auxiliary mobile hose reel cart crank was used, prior to placing it back in storage position, use it to crank trailer mounted extinguisher assembly hose assembly onto drum.

2-10. OPERATING PROCEDURES. - continued

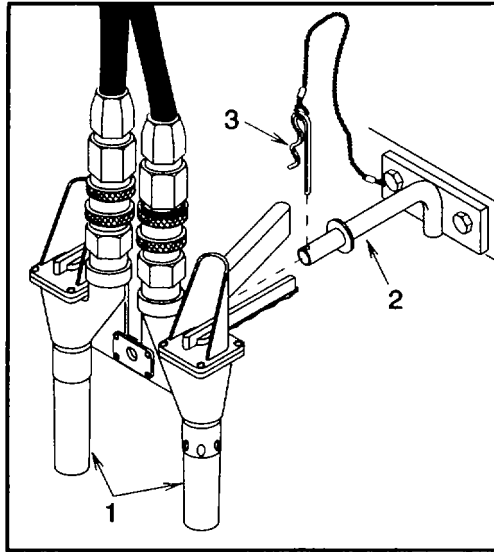

Figure 2-20. Return Fire Hose Nozzle to Operational Ready Condition

- (14) Secure crank (8) (fig. 2-19) to auxiliary mobile hose reel cart or trailer mounted extinguisher assembly with wing nut (6) and flat washer (7).
- (15) Notify unit maintenance for unit recharge.
- (16) Refill dry chemical tank.

WARNING

Cap must not be removed until tank pressure has been relieved. Severe injury can result if cap is removed while tank is pressurized.

CAUTION

When refilling dry chemical tank be sure NO water is introduced into the tank. Ensure that the dry chemical funnel and gage rod are completely dry prior to using them with the dry chemical. Moisture will cause the chemical to cake causing the system to fail.

- (a) Remove the cap (1) (fig. 2-21) from the dry chemical tank (2) Stir the dry chemical to break up any lumps and loosen if it has packed.
- (b) Check the dry chemical for hard lumps that would prevent the system from operating. If lumps are found, remove one and drop it from a height of four inches (10 centimeters) onto a hard surface. If the lump completely breaks apart, the dry chemical is only packed from settling and is in satisfactory condition. If the lump does not break apart completely, caking is present and the dry chemical must be replaced.

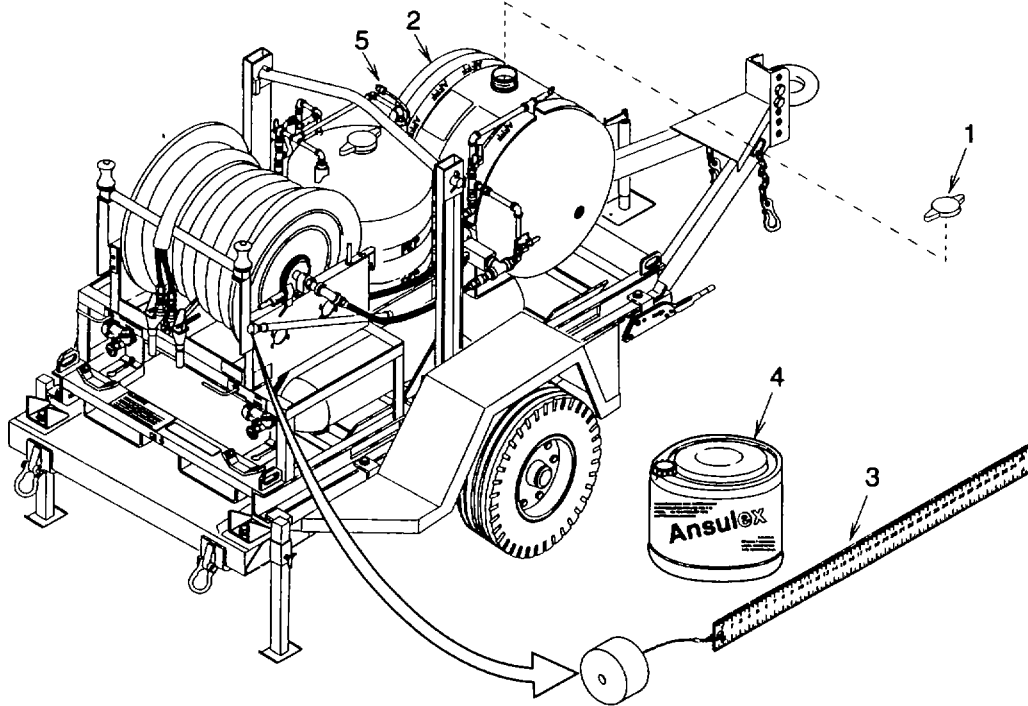

Figure 2-21. Refill Dry Chemical Tank

(c) Top off or refill the dry chemical tank (2) as needed with dry chemical (3) per table 2-4. Use dry chemical funnel (4) to add dry chemical and gage rod assembly (5) to check level.

Table 2-4. Dry Chemical Tank Refill Table

Distance from top of fill collar to surface of dry chemical.		Amount of dry chemical to add.
<i>Fresh</i>	<i>Settled (Packed)</i>	
Inches (Centimeters)	Inches (Centimeters)	Pounds (Kilograms)
45(11.4)	85(21.6)	None
8 5 (21.6)	11 5 (29 2)	50 (23)
11 5 (29.2)	14 (36)	100 (45)
14.5 (36.8)	17 (43)	150 (68)
18 (46)	20 (51)	200 (91)
21 5 (54.6)	23 (58)	250 (113)
24 5 (62.2)	25 5 (64.8)	300 (136)
28 (71)	28 5 (72.4)	350 (159)
31 (79)	31 5 (80.0)	400 (181)
36 (91)	36 (91)	450 (204)

(d) Replace cap (1) and tighten hand tight only

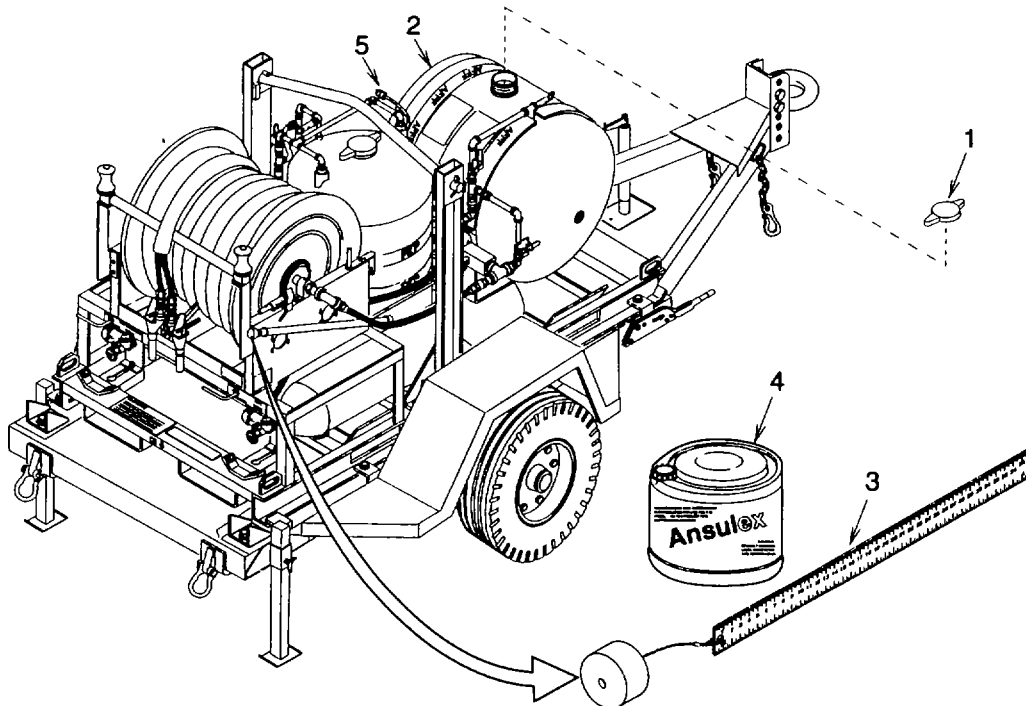
2-10. OPERATING PROCEDURES. - continued**(17) Refill AFFF tank.****Figure 2-22. Refill AFFF Tank****WARNING**

Cap must not be removed until tank pressure has been relieved. Severe injury can result if cap is removed while tank is pressurized.

- (a) Remove the cap (1) (fig. 2-22) from the AFFF tank (2).

CAUTION

Be careful not to damage the AFFF tank lining with metal hose ends or connections. The lining can be scratched or scored resulting in corrosion of the AFFF tank

NOTE

- Foam liquid will freeze, but the plastic container(s) used for shipment will expand safely with the ice. The foam liquid can be used after it thaws.
- Foam liquid must be disposed of in compliance with local, state, and federal regulations. Rinse any spill thoroughly with water as the foam liquid is slippery. The foam liquid poses no direct hazard, however it should be disposed of in limited quantities at a time to avoid nuisance foaming in sewer or waterway.

- (b) When refilling the AFFF tank (2), insert a hose against the bottom of the tank and add water to within nine inches (23 cm) of the fill collar top using gage rod (3) to measure distance, pour in the required amount of foam liquid (4) per table 2-5, then fill the AFFF tank with water until the foam liquid and water mixture is 4.5 inches (11.4 centimeters) from top of fill collar using gage rod to measure distance No further mixing of the solution is required after filling.

Table 2-5. AFFF Tank Refill Table

Distance from top of fill collar to surface of foam liquid and water mixture.	Amount of foam liquid to add.
Inches (Centimeters)	Gallons (Liters)
4.5 (11.4)	None
7 (18)	0.5 (1.9)
9.25 (23.50)	1 (4)
11.5 (29.2)	1.5 (5.7)
13.5 (34.3)	2 (8)
15.5 (39.4)	2.5 (9.5)
17 (43.2)	3 (11)
18.5 (47.0)	3.5 (13.3)
20.5 (52.1)	4 (15)
22.5 (57.2)	4.5 (17.0)
24.75 (62.87)	5 (19)
27 (68.6)	5.5 (20.8)
31.75 (80.65)	6 (23)

- (d) Replace cap (1) and tighten hand tight only.
- (e) If freezing weather exists, or is expected, connect the AFFF tank heater power cord (5) to power source.

2-11. DECALS AND INSTRUCTION PLATES.

Decals and instruction plates are attached on or near all valves, controls, tanks and the unit frame to indicate function and use of controls or identify the equipment with specific data.

PKP LEVEL REFILL TABLE		
PKP LEVEL:	TO REFILL TANK, ADD	
FROM TOP OF FILL COLLAR TO SURFACE OF PKP		
FRESH FILL CONDITION	-TO-	SETTLED CONDITION
4 1/2"	-	8 1/2"
8 1/2"	-	11 1/2"
11 1/2"	-	14"
14 1/2"	-	17"
18"	-	20"
21 1/2"	-	23"
24 1/2"	-	25 1/2"
28"	-	28 1/2"
31"	-	31 1/2"
36"	-	36"
		-FULL- 50 LBS. PKP.

SERIAL NO	DATE
MODEL NO 13229E3504	
GAWR EACH AXLE 6000	VEHICLE TYPE TRAILER EXTINGUISHER
LT235-85R16	This vehicle conforms to all applicable federal motor vehicle safety standards in effect on date of manufacture
16 X6 RIMS @ 80 PSI COLD SINGLE	

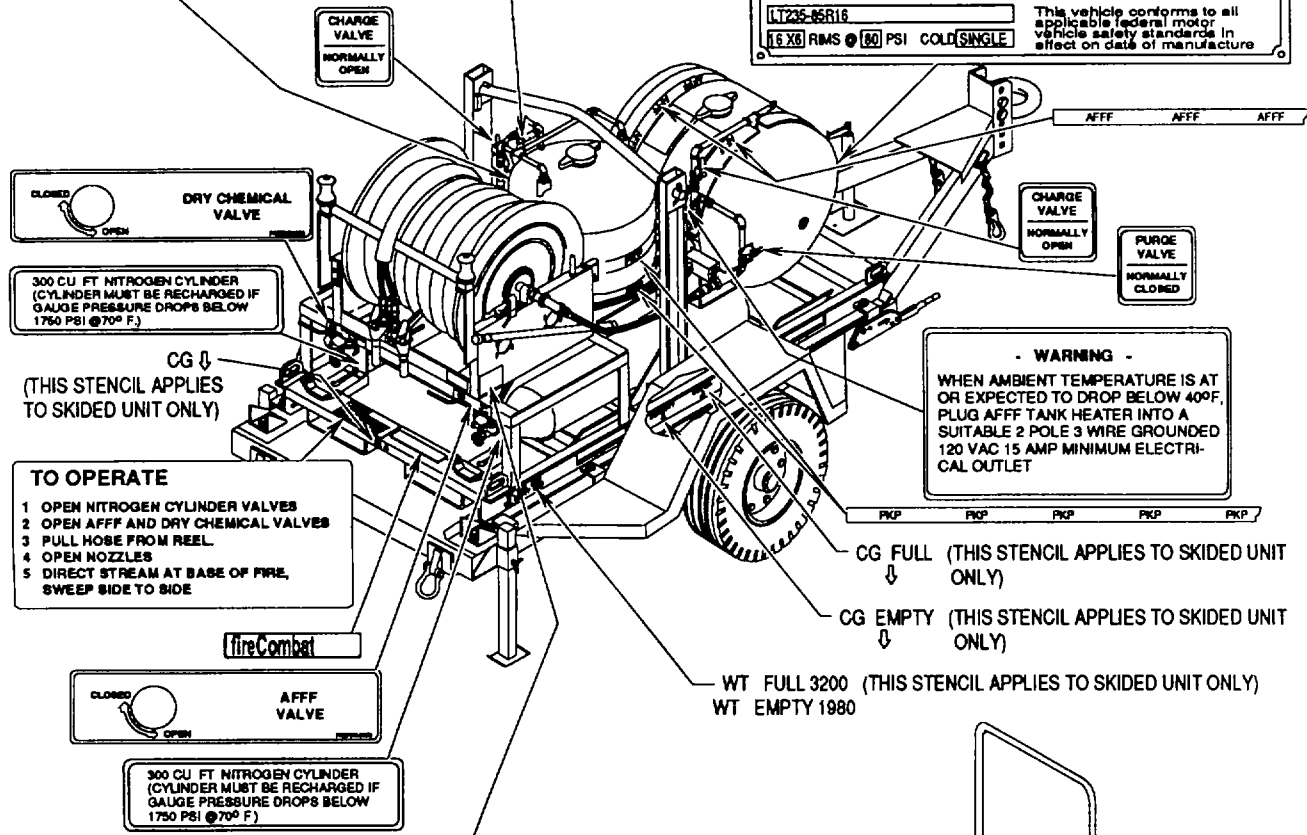

- TO OPERATE**
- 1 OPEN NITROGEN CYLINDER VALVES
 - 2 OPEN AFFF AND DRY CHEMICAL VALVES
 - 3 PULL HOSE FROM REEL
 - 4 OPEN NOZZLES
 - 5 DIRECT STREAM AT BASE OF FIRE, SWEEP SIDE TO SIDE

- WARNING -
WHEN AMBIENT TEMPERATURE IS AT OR EXPECTED TO DROP BELOW 40°F, PLUG AFFF TANK HEATER INTO A SUITABLE 2 POLE 3 WIRE GROUNDED 120 VAC 15 AMP MINIMUM ELECTRICAL OUTLET

U.S.	
EXTINGUISHER, FIRE, DRY CHEMICAL AND AQUEOUS FILM FORMING FOAM, SELF CONTAINED	
MODEL 450700 0884	CAPACITY 450 PKP 100 GA AFFF
SERIAL NO	YEAR OF MANUFACTURE
N.S.N. 4201 01-370-4212	CONT NO DAAG01 92 D-2082
SHIPPING WT 2880	LB. GROSS WT 3280
OVERALL HEIGHT 66	IN WIDTH 48 LENGTH 96
WARRANTY	MO DATE SHIPPED
MFD FIRE COMBAT, MARINETTE WI	INSP STAMP
BY USA CAGC NO. 84908	

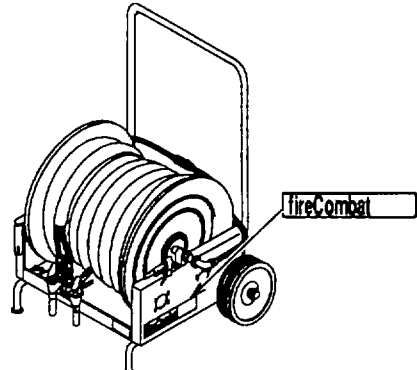

Figure 2-23. Information Plates (Sheet 1 of 2)

	STEP	NORMAL	AFTER USING	TO RECHARGE
NITROGEN CYLINDER(S)	1 VALVES	CLOSE	OPEN	CLOSE REFER TO NITROGEN CYLINDER PRESSURE TEMP CHART FOR REPLACEMENT NEED
	STEP	NORMAL	AFTER USING	TO RECHARGE
DRY CHEMICAL TANK	1 DRY CHEMICAL VALVE	CLOSED	CLOSE	CLOSED
	2 CHARGE VALVE	OPEN	CLOSE	CLOSED
	3 PURGE VALVE	CLOSED	OPEN	CLOSE
	4 DRY CHEMICAL HAND LINE NOZZLE(S)	CLOSED	OPEN NOZZLE(S) TO CLEAR HOSE LINE(S) OF DRY CHEMICAL. ALL HOSE LINES MUST BE CLEAR OF DRY CHEMICAL.	CLOSE
	5		RELIEVE ALL PRESSURE FROM TANK THROUGH HOSE LINE(S) BEFORE REMOVING FILL CAP	REPLACE CHEMICAL USED (TANK CAPACITY LBS)
	6		CLEAN FILL CAP COLLAR & GASKET GREASE THREADS AND GASKET WITH A GOOD GRADE OF HIGH TEMP GREASE	
	7		REPLACE FILL CAP SECURELY	
MODEL	NOTE SEE SERVICE MANUAL FOR MAINTENANCE AND PERIODIC INSPECTION INFORMATION			

fireCombat PART NO 04842

3% OR 6% AFFF LIQUID LEVEL REFILL TABLE

LIQUID LEVEL FROM TOP OF FILL COLLAR TO SURFACE OF LIQUID.	TO REFILL TANK, ADD:			
	AFFF U.S. GAL		WATER U.S. GAL	
	6%	3%	6%	3%
4 1/2 INCHES	FULL			
7	1/2	1/4	8	8 1/4
9 1/4	1	1/2	15 1/2	16
11 1/2	1 1/2	3/4	23 1/2	24 1/4
13 1/2	2	1	31	32
15 1/2	2 1/2	1 1/4	39	40 1/4
17	3	1 1/2	47	48 1/2
18 1/2	3 1/2	1 3/4	55	56 3/4
20 1/2	4	2	63	65
22 1/2	4 1/2	2 1/4	70 1/2	72 3/4
24 3/4	5	2 1/2	78	80 1/2
27	5 1/2	2 3/4	86	88 3/4
31 3/4	6	3	94	97

NOTE: 100 GALLON TANK TO BE REFILLED ON LEVEL GROUND

PART NO 08121

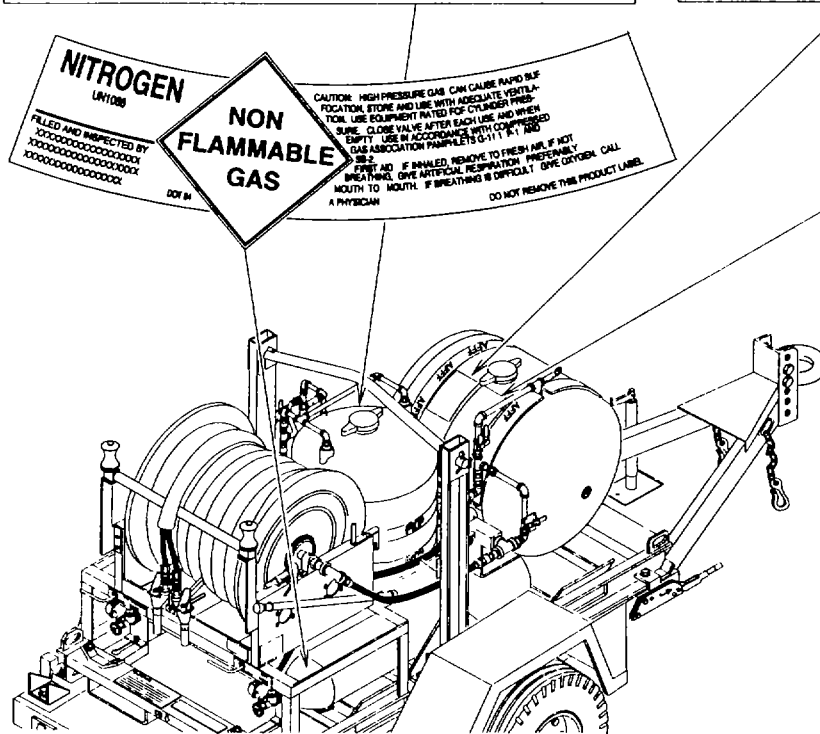

	STEP	NORMAL	AFTER USING	TO RECHARGE
NITROGEN CYLINDER(S)	1 VALVES	CLOSE	CLOSE	CLOSE REFER TO NITROGEN CYLINDER PRESSURE TEMP CHART FOR REPLACEMENT NEED
	STEP	NORMAL	AFTER USING	TO RECHARGE
DRY CHEMICAL TANK	1 AFFF VALVE	CLOSED	CLOSE	CLOSED
	2 CHARGE VALVE	OPEN	OPEN	CLOSE
	3 PURGE VALVE	CLOSED	OPEN	CLOSE
	4 AFFF HAND LINE	CLOSED	OPEN NOZZLE(S) TO CLEAR HOSE LINE(S) OF AFFF. ALL HOSE LINES MUST BE CLEAR OF AFFF.	CLOSE
	5		RELIEVE ALL PRESSURE FROM TANK THROUGH HOSE LINE(S) BEFORE REMOVING FILL CAP	REPLACE SOLUTION USED (TANK CAPACITY US GALS) RATIO 1 GAL AFFF CONCENTRATE TO 14 GAL WATER OR AFFF OR RATIO 1 GAL AFFF CONCENTRATE TO 28 GAL WATER OR AFFF SOLUTION PREPARED AT 3% - FILL TO 2 INCHES BELOW BOTTOM OF FILL COLLAR. STOP FOR 30 SECONDS WITH HORIZONTAL NOZ.
	6		CLEAN FILL CAP COLLAR & GASKET GREASE THREADS AND GASKET WITH A GOOD GRADE OF HIGH TEMP GREASE	
	7		REPLACE FILL CAP SECURELY	
MODEL	NOTE SEE SERVICE MANUAL FOR MAINTENANCE AND PERIODIC INSPECTION INFORMATION			

fireCombat PART NO 08114

Figure 2-23. Information Plates (Sheet 2 of 2)

2-12. PREPARATION FOR MOVEMENT

- a. Disconnect AFFF tank heater power cord (1) from power source, if connected, and secure power cord.
- b. The AFFF tank (2) must be drained if there is a danger of freezing while moving. Notify unit maintenance.
- c. Secure hose assemblies (3) on both auxiliary mobile hose reel cart (4) and trailer mounted extinguisher assembly (5) drums (6) and tighten rewind brakes (7) securely to prevent unwinding.
- d. The trailer mounted extinguisher assembly (5) can be towed short distances while the auxiliary mobile hose reel cart (4) can be rolled very short distances or lifted by its frame and placed on a truck or similar vehicle.

(1) Lower the jack (8) to remove pressure from the two rear jack stands (9). Loosen the two handles (10) and raise each rear jack stand. Tighten handle into lower hole of each jack stand.

(2) Use the jack (8) to position the lunette eye pintle (11) onto the towing vehicle. Secure towing vehicle hitch.

(3) Connect safety chains (12) to towing vehicle.

(4) Retract the jack (8) completely and position from the support (vertical) position to the towing (horizontal) position.

WARNING

Equipment is provided with hand brakes only and is not equipped with lights or reflectors. Not intended for over the road towing, personal injury can result. (5) Release both parking brakes (13). When released, vehicle can be moved.

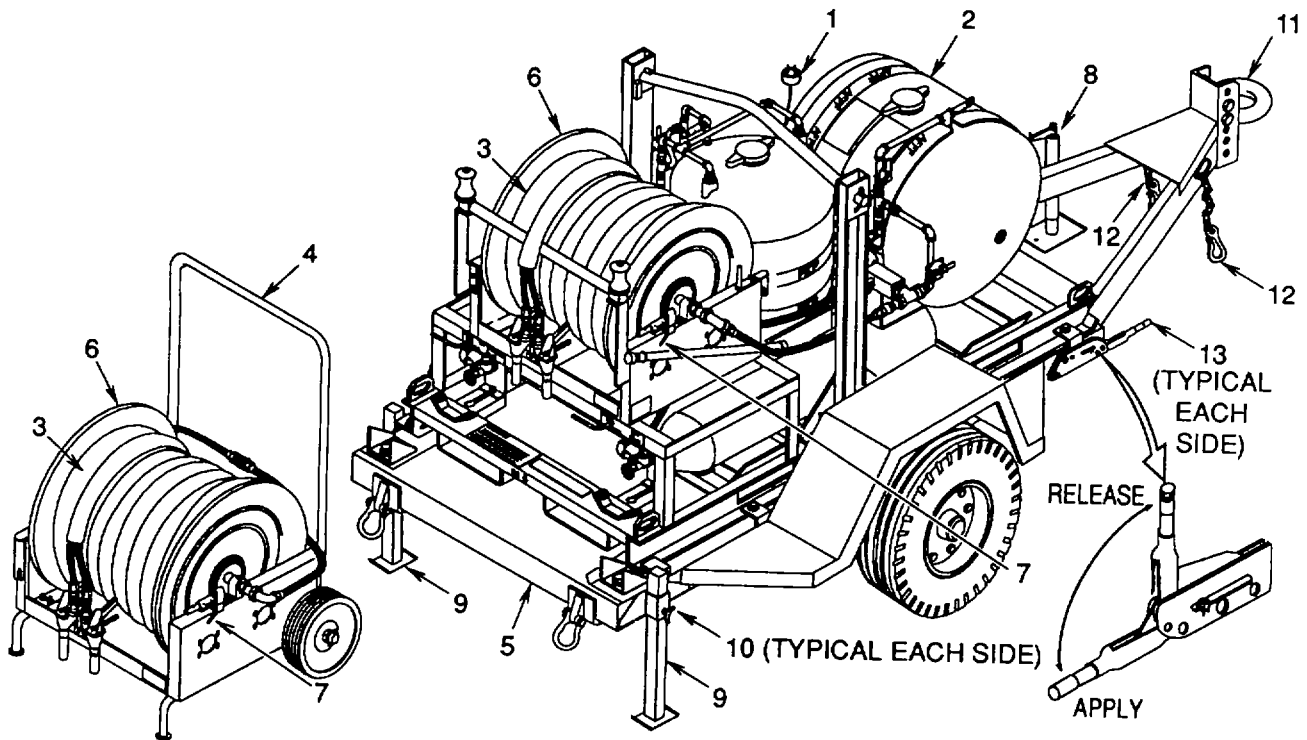

Figure 2-24. Preparation for Movement

e. For long distance, the trailer mounted extinguisher assembly (5) and auxiliary mobile hose reel cart (4) must be loaded and secured onto a truck, trailer, or other suitable carrier

WARNING

Clothing items must be kept dry. Steam produced by high heat can cause severe burns f. Be sure manuals, dry chemical funnel, clothing items, chemicals, and nitrogen cylinders are properly packed and secured from being lost or damaged when moving equipment.

Section IV. OPERATION UNDER UNUSUAL CONDITIONS

2-13. EXTREME HEAT.

a. The Fire Suppression Equipment Set is designed to operate effectively in any tropical climate. Shade should be provided for the equipment and/or personnel should wear gloves as protection from hot metal surfaces b. The nitrogen cylinder pressure is affected by temperature changes. See table 2-6 for recommended operating pressures at various temperatures.

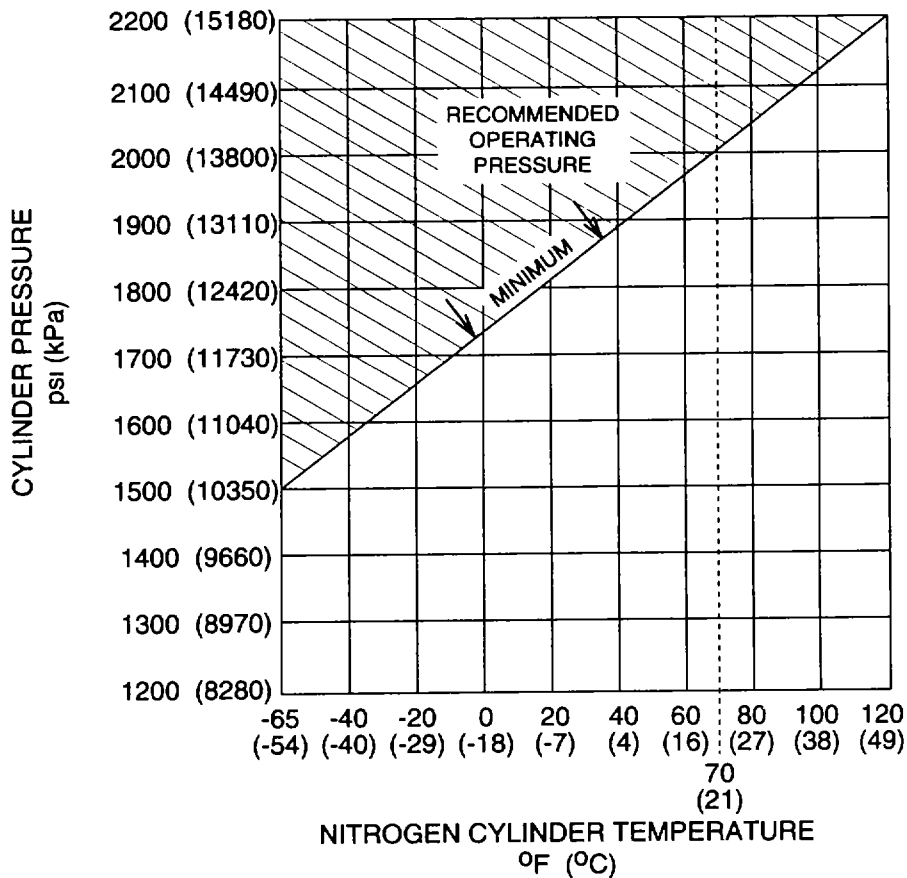

Table 2-6. Nitrogen Cylinder Pressure/Temperature Chart

2-14. EXTREME COLD.

a. In freezing weather operation, the AFFF tank heater must be used at all times. The heater is only designed to maintain the temperature of the AFFF chemical agent above freezing in temperatures down to -40° F (-40° C)

b. The nitrogen cylinder pressure is affected by temperature changes. See table 2-6 for recommended operating pressures at various temperatures.

2-15. SALT AIR OR SEA SPRAY

Salt presents a serious corrosion problem and all equipment coming in contact with salt water or salt fog should be flushed or sponged with fresh clean water as soon as possible then dried thoroughly.

2-16. DUSTY OR SANDY ENVIRONMENT.

In desert regions, protection should be provided to shield the Fire Suppression Equipment Set from blowing sand.

2-17. EMERGENCY PROCEDURES.

If either the AFFF or dry chemical system fails to operate or becomes inoperative during operation, the remaining system may be used to extinguish the fire. The systems operate completely independent of each other.

2-18. NUCLEAR, BIOLOGICAL, AND CHEMICAL (NBC) DECONTAMINATION PROCEDURES**NOTE**

Detailed decon procedures can be found in: FM 3-3, FM 3-4, and FM 3-5.

Decon procedures take time. Do as much as you can based on the tactical situation.

- a. General The following emergency procedures can be performed until field NBC decon facilities are available.
- b. Emergency Procedures: If NBC attack is known or suspected Mask at once and continue mission If outside, follow decon procedures below to avoid taking contamination into controlled area Do not unmask until told to do so.

(1) Nuclear decontamination. Brush fallout from skin, clothing, and equipment with available brushes, rags, and tree branches Wash skin and have radiation check made as soon as tactical situation permits.

(2) Biological decontamination Remain masked and continue mission until told to unmask

WARNING

Do not use decontamination spray on personnel It could cause personal injury.

(3) Chemical detection and decontamination:

(a) Use M8 paper from the M256 Chemical Agent Detector Kit or M9 paper to determine If liquid agent is present on the equipment

(b) If exposure to liquid agent is known or suspected, clean exposed skin, clothing, personal gear, and equipment, in that order using M258A1 kit. Use the buddy system. Wash exposed skin and thoroughly decontaminate as soon as tactical situation permits.

(c) If the M8 or M9 paper indicates that liquid chemical agent is present on the equipment, use the NBCM 11 decon apparatus for decon of equipment

2-55/(2-56 blank)

CHAPTER 3 OPERATOR MAINTENANCE INSTRUCTIONS

Section I. LUBRICATION INSTRUCTIONS

Lubrication instructions are in appendix F, of this TM. All lubrication instructions are mandatory.

Section II. OPERATOR TROUBLESHOOTING PROCEDURES

3-1. GENERAL.

The branching logic tree diagrams list common malfunctions that you may find with your equipment. Follow the instructions given in the order they appear.

The branching logic tree diagrams cannot list all the malfunctions that may occur, all the steps needed to find the fault, or all the corrective actions needed to correct the fault. If the equipment malfunction is not listed or corrective actions taken do not correct the fault, notify your supervisor.



3-2. FIRE FIGHTING AGENTS WILL NOT DISCHARGE FROM THE NOZZLES.

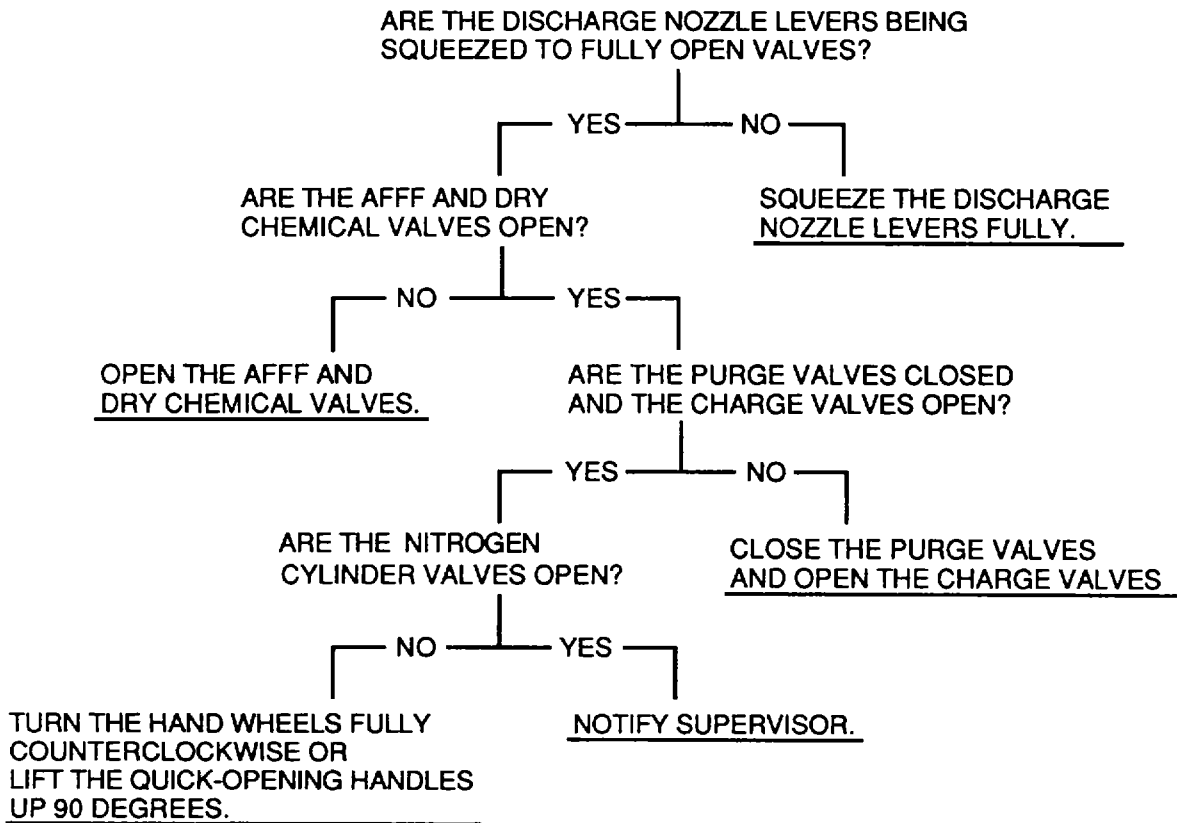

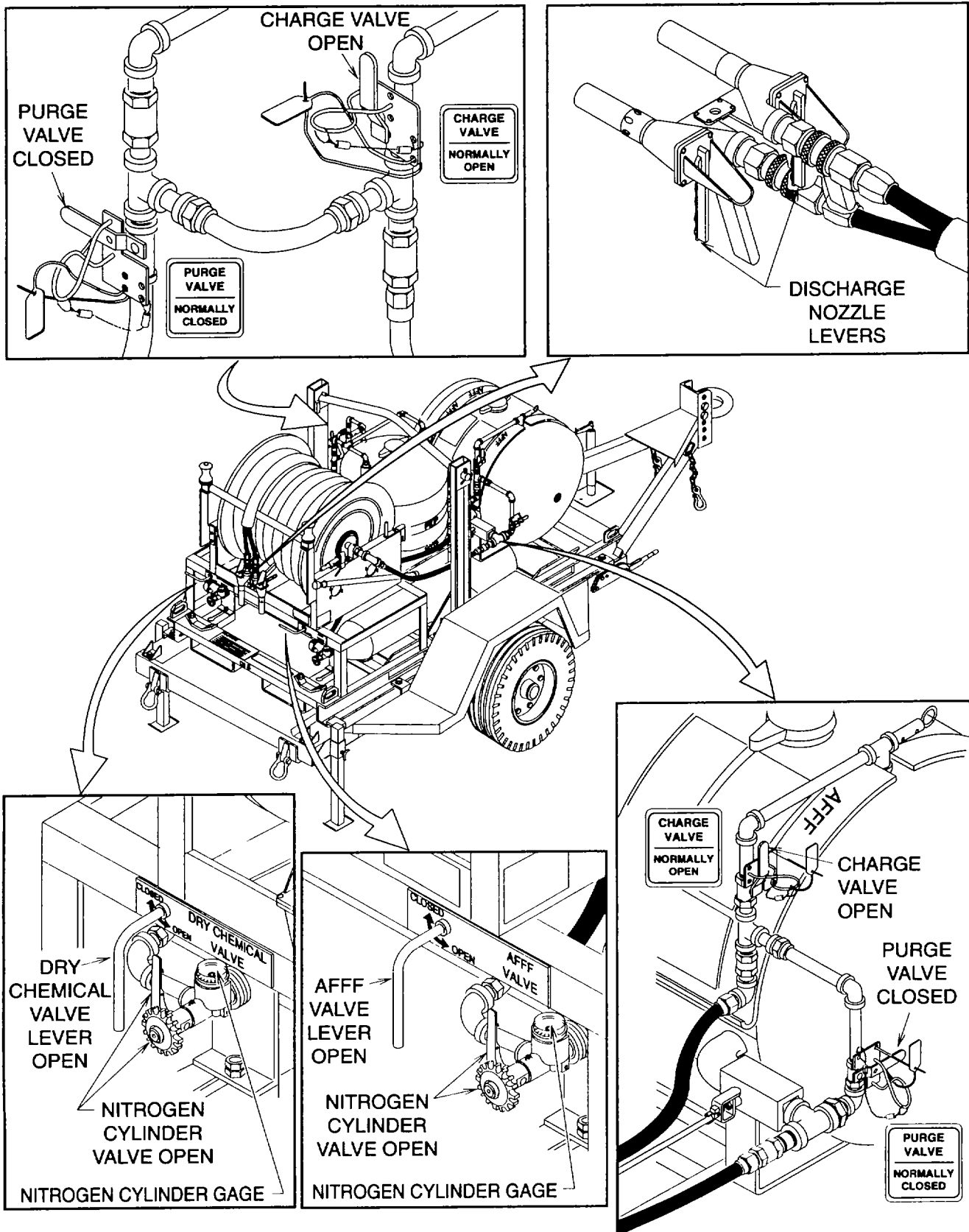

Figure 3-1. Operator Troubleshooting Items

Section III. MAINTENANCE PROCEDURES

3-3. GENERAL.

Operator maintenance is limited to the inspections referred to in Operator Preventive Maintenance Checks Table 2-1 and servicing performed during operational checks. See paragraph 2-8.

CHAPTER 4 UNIT MAINTENANCE INSTRUCTIONS

Section I. LUBRICATION INSTRUCTIONS

Lubrication instructions are in appendix F, of this TM. All lubrication instructions are mandatory.

Section II. REPAIR PARTS, TOOLS, SPECIAL TOOLS, TEST, MEASUREMENT AND DIAGNOSTIC EQUIPMENT (TMDE), AND SUPPORT EQUIPMENT

For authorized common tools and equipment refer to the Modified Table of Organization and Equipment (MTOE) CTA 50-970 or CTA 8-100 as applicable to your unit.

4-1. SPECIAL TOOLS.

The following special tool is required for unit maintenance Use of this tool is described in Section VI of this chapter.

Tank Lifting Tool (94833) 140K0084.

Section III. SERVICE UPON RECEIPT

4-2. UNLOADING.

(1) The fire suppression equipment set is packed securely inside an ISO container and consists of the following:

One auxiliary mobile hose reel cart.

One trailer mounted extinguisher assembly.

One crate containing: Five dry chemical fire extinguishers.

Three aluminized fireman's hoods.

Five pair fireman's boots (size: 6, 7, 8, 9, and 10).

Three aluminized fireman's trousers (size: small, medium, and large).

Three aluminized fireman's gloves (size: large).

Three aluminized fireman's coats (size: small, medium, and large).

One shoulder harness.

One dry chemical funnel.

One manual(s).

4-2. UNLOADING - continued

Five liquid foam containers (five gallons (19 liters) each) and 36 dry chemical containers (50 pounds (23 kilograms) each) Six nitrogen cylinders (300 cubic feet (85 cubic meters) each).

WARNING

Be sure lifting device is capable of lifting the specified weight or personal injury could result.

CAUTION

If hoisting the auxiliary mobile hose reel cart, use sufficiently long slings and spreader bars or equipment damage can result.

(2) Remove tiedowns and braces or supports used to secure equipment in ISO container. Remove all equipment from container.

(3) The trailer mounted extinguisher assembly weighs approximately 3454 pounds (1567 kilograms) and has a lifting bar attached to allow for hoisting. The auxiliary mobile hose reel cart weighs approximately 455 pounds (206 kilograms) and can be hoisted using slings and spreader bars.

4-3. UNPACKING.

Remove pin and fire hose nozzle assemblies from post and release rewind brake assembly and completely unwind the hose assembly from the both the trailer and cart mounted hose reels. Remove the protective plastic covering from each hose assembly. Using crank, rewind hose assembly onto hose reel and tighten rewind brake assembly just enough to prevent hose from unwinding under its own weight but not too tight preventing the hose assembly from being pulled off reel. Secure fire hose nozzle assemblies to post with pin.

4-4. PROCESSING.

a. Inspect the equipment for damage incurred during shipment. If the equipment has been damaged, report the damage on SF 364, Report of Discrepancy.

b. Check the equipment against the packing slip to see if shipment is complete. Report all discrepancies in accordance with instructions of DA Pam 738-751 as applicable.

c. Issue protective clothing to appropriate operating personnel.

d. Perform both unit and operator "Before" PMCS.

4-5. INSTALLATION.

- a. Remove shipping cap (1) and store with accessory equipment
- b. Remove valve plug (2)
- c. Connect hose assembly fitting (3) to cylinder valve (4) and tighten.

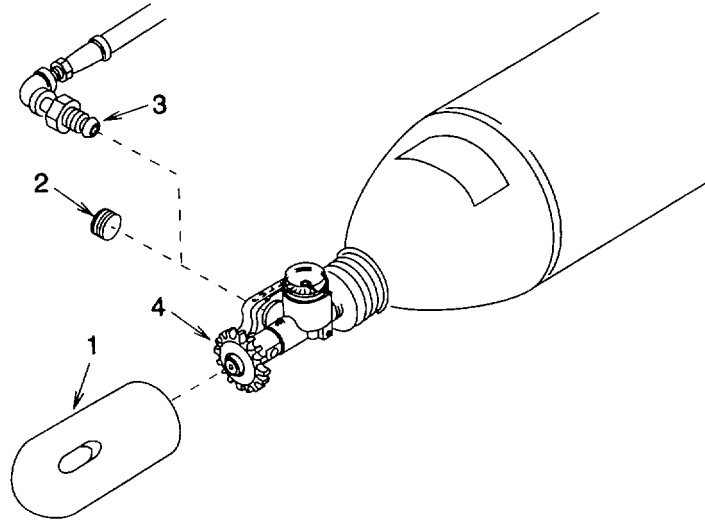

Figure 4-1. Cylinder Hose Connection

- d. Orient the equipment on site per paragraph 2-8.
- e. Setup, check, and service the equipment per paragraph 2-8.
- f. Lubricate per Appendix F
- g. Check tire pressure (80 psig (552 kPa))
- h. Perform functional check on parking brakes per paragraph 4-29

Section IV. UNIT PREVENTIVE MAINTENANCE CHECKS AND SERVICES (PMCS)

4-6. GENERAL.

a. Systematic, periodic, preventive maintenance checks and services (PMCS) are essential to insure that the fire suppression equipment set is ready for operation at all times. The purpose of a preventive maintenance program is to discover and correct defects and deficiencies before they can cause serious damage or complete failure of the equipment. Any effective preventive maintenance program must begin with training the operators to report all unusual conditions that they note during their PMCS or actual operation.

b. A schedule for unit preventive maintenance inspection and service should be established immediately after installation of the fire suppression equipment set. A quarterly interval, equal to three calendar months, is recommended for usual operating conditions. When operating under unusual conditions, such as a very dusty, sandy, wet, or humid environment, it may be necessary to reduce the interval to monthly or even less if conditions are extreme.

c. Table 4-1 lists the unit preventive maintenance checks and services that should be performed at quarterly (or otherwise established) intervals. The PMCS items in the table have been arranged and numbered in a logical sequence to provide for greater personnel efficiency and least amount of required maintenance downtime. The paragraph reference information included in the procedure column provides the paragraph number where detailed, step-by-step disassembly/reassembly maintenance procedures may be found.

d. Be sure to perform your PMCS each time the Fire Suppression Equipment Set is used.

e. Use DA Form 2404 (Equipment Inspection and Maintenance Worksheet) to record any faults that you discover performing your PMCS. The item number column in table 4-1 will be used as a source of item numbers for the TM Number Column on this form. You DO NOT need to record faults that you fix.

4-7. PMCS PROCEDURES.

- a. The "INTERVAL" column of table 4-1 tells you when to do a certain check or service.
- b. The "PROCEDURE" column of table 4-1 tells you how to do required checks and services.

NOTE

Terms "ready/available" and "mission capable" refer to same status: Equipment is on hand and ready to perform its mission. (See DA Pam 738-750.)

c. The "NOT FULLY MISSION CAPABLE IF:" column in table 4-1 tells you when your equipment is non-mission capable and why it cannot be used.

Table 4-1. Unit Preventive Maintenance Checks and Services for Fire Suppression Equipment Trailer Set

ITEM NO	INTERVAL	ITEM TO BE CHECKED OR SERVICED	PROCEDURE	NOT FULLY MISSION CAPABLE IF:
1	Weekly	Dry Chemical	Stir dry chemical to break up any lumps.	Dry chemical will not break up.
2	Quarterly	Nipple/Couplers	Open coupling halves, visually inspect preformed packing open or close	Preformed packing missing or damaged. Coupling half will not
3	Quarterly	Regulating Valves	Check regulating valves for any physical damage or evidence of leaking.	Regulating valve is damaged or leaking

Table 4-1. Unit Preventive Maintenance Checks and Services for Fire Suppression Equipment Trailer Set - continued

ITEM NO	INTERVAL	ITEM TO BE CHECKED OR SERVICED	PROCEDURE	NOT FULLY MISSION CAPABLE IF:
4	Quarterly	Tires/Wheels	<p>a. Check trailer tires for proper inflation 75-80 psig (518-552 kPa) and any evidence of leaking.</p> <p>b. Check wheels for any physical damage and check that the nuts are tight.</p>	<p>Tires are very low</p> <p>Wheel nuts are loose or missing.</p>
5	Quarterly	Brakes	<p>a. Check condition of brakes. paragraph 4-29.</p> <p>b. Check adjustment of parking brake See paragraph 4-29.</p> <p>c. Use an oil can or other suitable means and apply oil as required to allow pivot points to move freely. Wipe off excess oil with a clean rag. Use SAE engine oil, OE-10.</p>	<p>See Brakes are worn too thin to prevent trailer from moving</p> <p>Parking brake will not prevent trailer from moving.</p>
6	Quarterly	Drive Gears	<p>Use an oil can or other suitable means and apply oil as required to allow gears to rotate freely. Wipe off excess oil with a clean rag. Use SAE engine oil, OE-10.</p>	
7	Quarterly	Crank	<p>Use an oil can or other suitable means and apply oil as required to allow hand swivel to rotate freely. Wipe off excess oil with a clean rag. Use SAE engine oil, OE-10.</p>	
8	Quarterly	Hose Rollers	<p>Use an oil can or other suitable means and apply oil as required to allow roller tube and spools to rotate freely. Wipe off excess oil with a clean rag Use SAE engine oil, OE-10.</p>	
9	Quarterly	Cart Wheel Bearings	<p>Attach grease gun to lubrication fitting and apply grease until it comes out around shaft. Remove grease gun and wipe off excess grease with clean rag. Use general purpose grease or equivalent.</p>	
10	Annually	Swivel Joints	<p>Lubricate swivel joint. See paragraph 4-15.</p>	

ITEM NO	INTERVAL	ITEM TO BE CHECKED OR SERVICED	PROCEDURE	NOT FULLY MISSION CAPABLE IF:
11	Annually	Hose Reel Bearings	Attach grease gun to lubrication fitting and apply grease until it comes out around shaft. Remove grease gun and wipe off excess grease with clean rag. Use general purpose grease or equivalent	
12	Annually	Rewind brake assembly	Attach grease gun to lubrication fitting and apply grease until it comes out around shaft. Remove grease gun and wipe off excess grease with clean rag. Use general purpose grease or equivalent	
13	Annually	Trailer Wheel Bearings	Lubricate, re-pack, wheel bearings. See paragraph 4-30.	

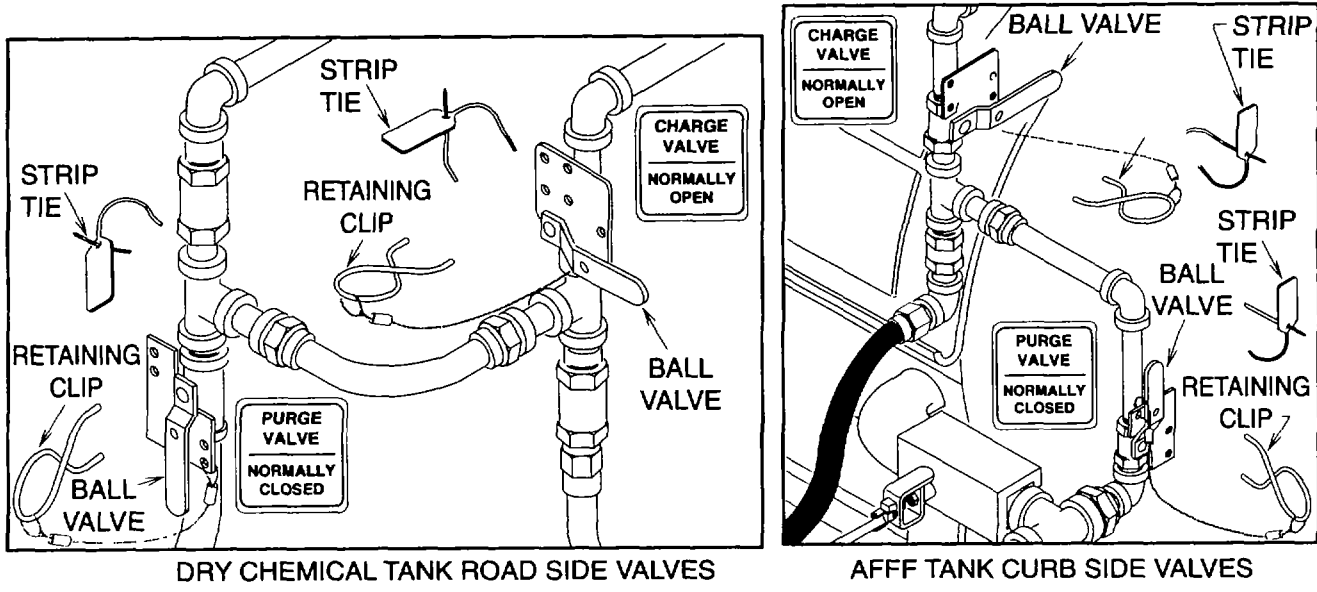

14	Annually	Unit Functional Check	<p style="text-align: center;">NOTE</p> <p>This check will not pressurize the Dry chemical or AFFF tanks, nor discharge any fire fighting chemical.</p> <p>a. Remove strip ties and pull retaining clips from two each ball valves.</p> <p>b. Close both charge ball valves and open both purge ball valves.</p>	
----	----------	-----------------------	--	--

Table 4-1. Unit Preventive Maintenance Checks and Services for Fire Suppression Equipment Trailer Set - continued

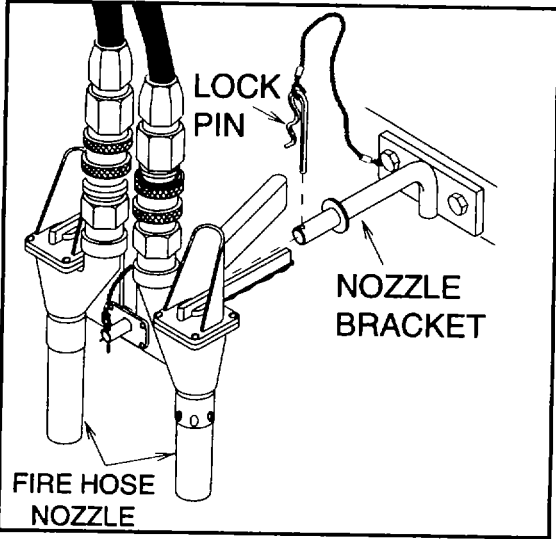
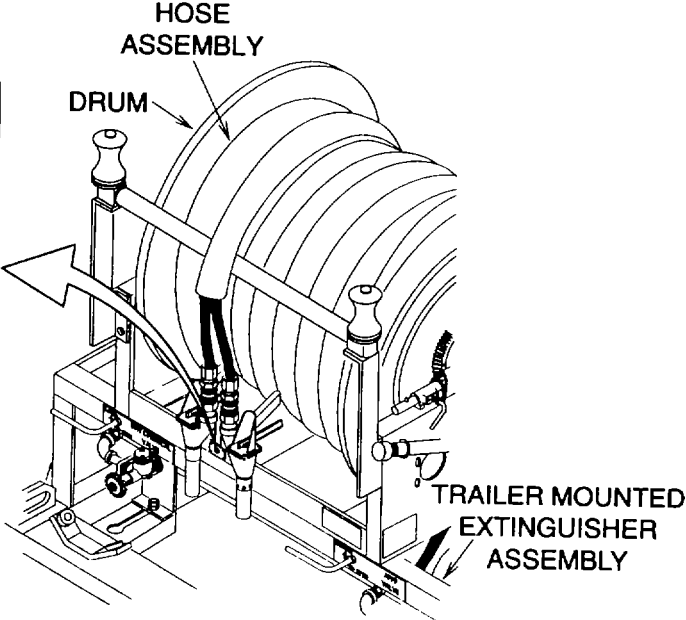
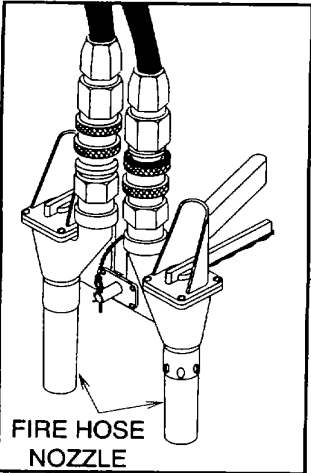
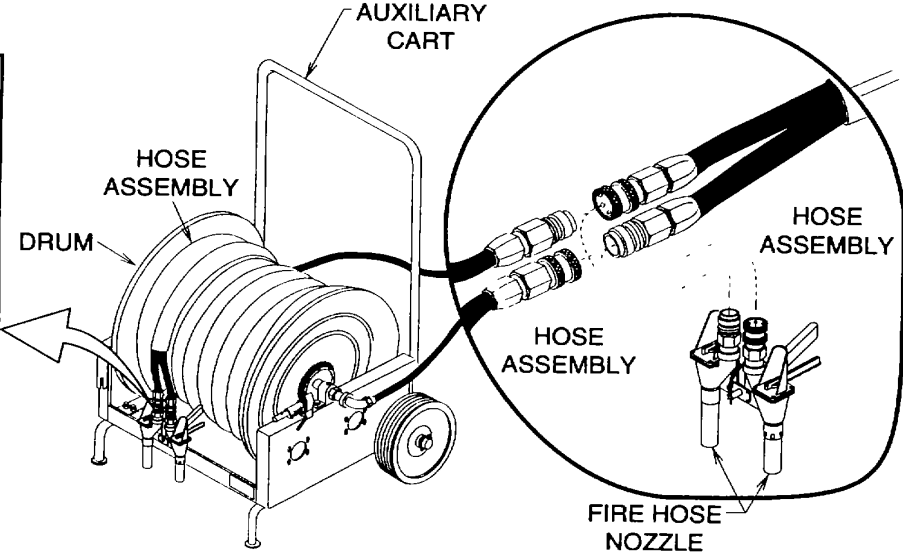
ITEM NO	INTERVAL	ITEM TO BE CHECKED OR SERVICED	PROCEDURE	NOT FULLY MISSION CAPABLE IF:
		 <p>LOCK PIN NOZZLE BRACKET FIRE HOSE NOZZLE</p>	 <p>HOSE ASSEMBLY DRUM TRAILER MOUNTED EXTINGUISHER ASSEMBLY</p> <p>c. On the trailer mounted extinguisher assembly, pull lock pin and remove fire hose nozzles from nozzle bracket Walk toward the auxiliary mobile hose reel cart while pulling the hose assembly completely off drum.</p>	
		<p>Unit Functional Check - continued</p>  <p>FIRE HOSE NOZZLE</p>	 <p>AUXILIARY CART HOSE ASSEMBLY DRUM HOSE ASSEMBLY FIRE HOSE NOZZLE</p>	

ITEM NO	INTERVAL	ITEM TO BE CHECKED OR SERVICED	PROCEDURE	NOT FULLY MISSION CAPABLE IF:
		<p>Unit Functional Check - continued</p>	<p>d. Remove fire hose nozzles from trailer mounted extinguisher assembly hose assembly. Separate the auxiliary mobile hose reel cart inlet hose assemblies and connect to trailer mounted extinguisher assembly hose assembly</p> <p>e. On the auxiliary mobile hose reel cart, pull lock pin and remove fire hose nozzles from nozzle bracket. Pull the hose assembly completely off drum.</p>	
<p>HAND WHEEL QUICK RELEASE LEVER GAUGE NITROGEN CYLINDERS CROSS SHAFT OPEN CLOSE STRIP TIES</p> <p>TYPICAL FOR BOTH NITROGEN CYLINDER VALVES</p>				
			<p>f. Remove two strip ties from each cylinder valve. Open (raise) both nitrogen cylinder valve quick release levers</p> <p>g. Listen for any leaks in system.</p> <p>h. Momentarily squeeze the fire hose nozzle valve levers one at a time and check fire hose nozzle discharge for any foreign material. Gas only should escape.</p> <p>i. Turn each cylinder valve hand wheel fully counterclockwise (open). Close (lower) quick release lever. Rotate cross shaft until flat is horizontal. Turn hand wheel fully clockwise (closed).</p>	<p>Any leaks are found.</p> <p>No gas escapes or any foreign material is discharged</p>

**Table 4-1. Unit Preventive Maintenance Checks and Services for Fire Suppression Equipment
Trailer Set - continued**

ITEM NO	INTERVAL	ITEM TO BE CHECKED OR SERVICED	PROCEDURE	NOT FULLY MISSION CAPABLE IF:
		Unit Functional Check - continued	<p>j. Squeeze both fire hose nozzle valve levers to relieve system pressure.</p> <p>k. Remove fire hose nozzles and install the ones removed from the trailer mounted extinguisher assembly hose assembly.</p> <p>l. Open (raise) both cylinder valve quick release levers.</p> <p>m. Repeat steps h. through j.</p> <p>n. Disconnect the trailer mounted extinguisher assembly hose assembly from the auxiliary mobile hose reel cart inlet hose assemblies. Connect the auxiliary mobile hose reel cart inlet hose assemblies together and install the loose fire hose nozzles to the trailer mounted extinguisher assembly hose assembly.</p> <p>o. On both the trailer mounted extinguisher assembly and the auxiliary mobile hose reel cart, install crank onto brake shaft and rewind hose assembly onto drum. Install fire hose nozzles onto nozzle bracket and secure with lock pin.</p> <p>p. Open both charge ball valves and close both purge ball valves. Place retaining clips over each ball valve handle.</p> <p>q. Install one new strip tie on each ball valve retaining clip.</p> <p>r. Install two new strip ties on each cylinder valve.</p>	

ITEM NO	INTERVAL	ITEM TO BE CHECKED OR SERVICED	PROCEDURE	NOT FULLY MISSION CAPABLE IF:
			<p>s. Check gage for pressure in each cylinder.</p>	<p>Normal operation: Pressure below 1750 psi. (12075 kPa). Cold weather operation: Pressure below that listed for current temperature.</p> <p><u>COLD WEATHER RANGE</u> -40 = 1575 psi (10868 kPa) -20 = 1650 psi (11385 kPa) 0 = 1725 psi (11903 kPa) 10 = 1750 psi (12075 kPa)</p>

Section V. UNIT TROUBLESHOOTING

4-8 GENERAL.

The branching logic tree diagrams list common malfunctions that you may find with your equipment. Follow the instructions given in the order they appear.

The branching logic tree diagrams cannot list all the malfunctions that may occur, all the steps needed to find the fault, or all the corrective actions needed to correct the fault. If the equipment malfunction is not listed or corrective actions taken do not correct the fault, notify your supervisor.

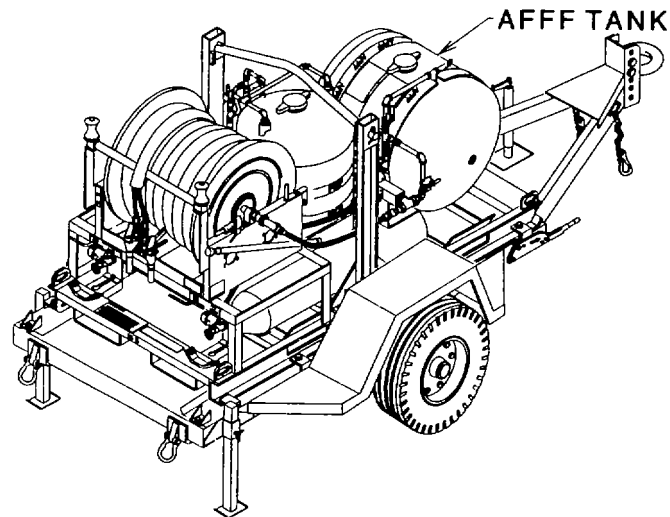
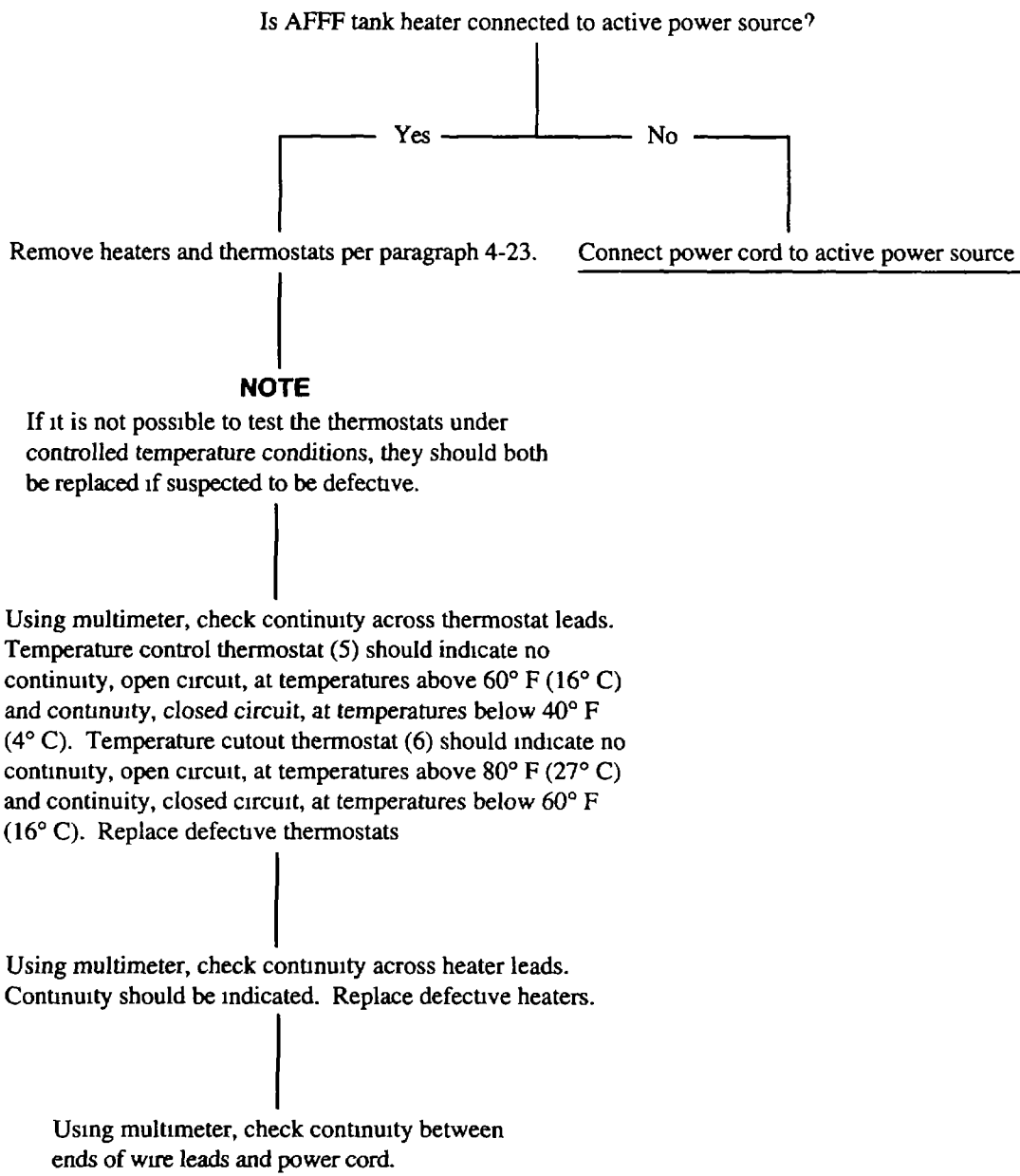

Figure 4-2. AFFF Solution

4-9. AFFF SOLUTION FROZEN.



Section VI. MAINTENANCE PROCEDURES

4-10. GENERAL.

The procedures in this section have been arranged in the order in which the items appear in the Unit (0) maintenance level column on the Maintenance Allocation Chart (MAC) which is provided in Appendix B. Step-by-step procedures have been provided for all actions authorized to be performed by unit maintenance in the order in which they appear on the MAC. Actions authorized to be performed by direct support maintenance have been duly noted step-by-step procedures for these actions may be found in chapter 5.

4-11. CYLINDER ASSEMBLY REPLACEMENT.

This task covers: a. Removal b Installation

INITIAL SETUP

Tools

General Mechanics Tool Kit, Appendix B, Section III,

Materials/Parts

Lock Washers (2), Appendix I, item 3

Strip Ties (3), Appendix I, Item 29

Personnel Required

Two

General Safety Instructions

WARNING

- **The pressure in a nitrogen cylinder can exceed 2000 psi (13800 kPa) which could cause serious personal injury. System pressure must be relieved before servicing the equipment.**
- **Nitrogen is an inert gas that can cause suffocation and must be discharged in a well ventilated area to avoid personal injury.**
- **To avoid injury to personnel, two people are required to lift cylinder.**
- **Be sure trailer is reasonably level and secure to prevent personal injury.**

a. Removal

Replace either nitrogen cylinder when pressure indicated is below 1750 psi. (12075 kPa)

WARNING

- **The pressure in a nitrogen cylinder can exceed 2000 psi (13800 kPa) which could cause serious personal injury. System pressure must be relieved before servicing the equipment.**
- **Nitrogen is an inert gas that can cause suffocation and must be discharged in a well ventilated area to avoid personal injury.**
- **To avoid injury to personnel, two people are required to lift cylinder.**
- **Be sure trailer is reasonably level and secure to prevent personal injury.**

NOTE

Procedures are the same for either the dry chemical or AFFF system.

- (1) Close cylinder valve if open
 - (a) Turn cylinder valve hand wheel (1) (fig. 4-3) fully counterclockwise (open).
 - (b) Close (lower) quick release lever (2) and rotate cross shaft (3) until flat is horizontal
 - (c) Turn hand wheel (1) fully clockwise (closed).

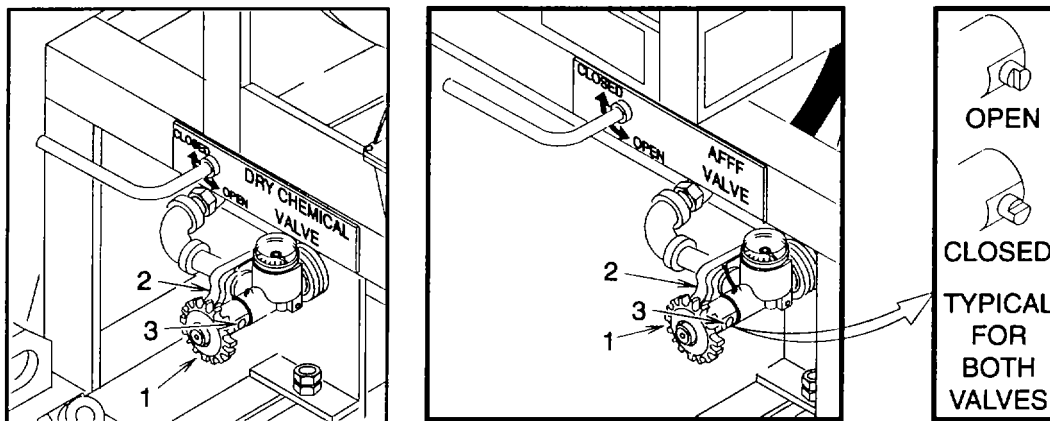

Figure 4-3. Cylinder Valves

- (2) Relieve system pressure
 - (a) Remove strip tie (1) (fig. 4-4).
 - (b) Pull retaining clip (2).
 - (c) Open ball valve (3).
 - (d) Squeeze fire hose nozzle valve lever (1) (fig 4-5) to relieve system pressure.
 - (e) Close ball valve (3) (fig 4-4)
 - (f) Install retaining clip (2) over ball valve (3) handle.
 - (g) Install new strip tie (1).

4-11. CYLINDER ASSEMBLY REPLACEMENT. - continued

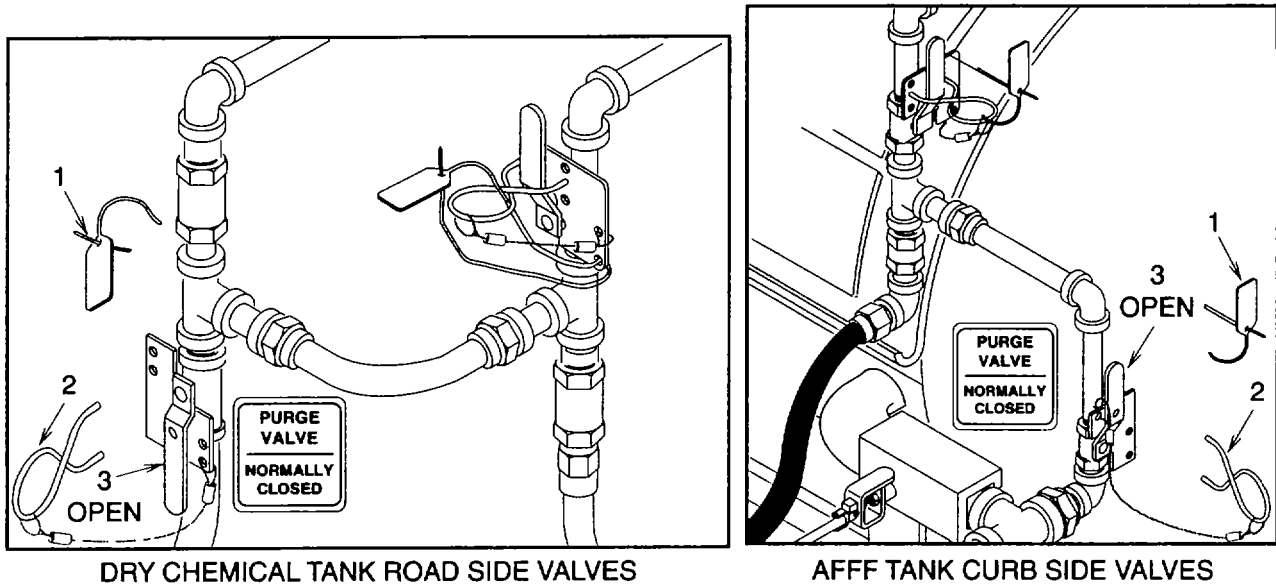

Figure 4-4. Ball Valves

- (3) Remove hose assembly (2) (fig 4-5) from valve (1) (fig. 4-3) and install shipping plug (3) (fig. 4-5). Care must be taken to protect the hose assembly fitting from damage when loose
- (4) Place shipping cap (4) over valve and secure to cylinder (5). Hand tighten only.

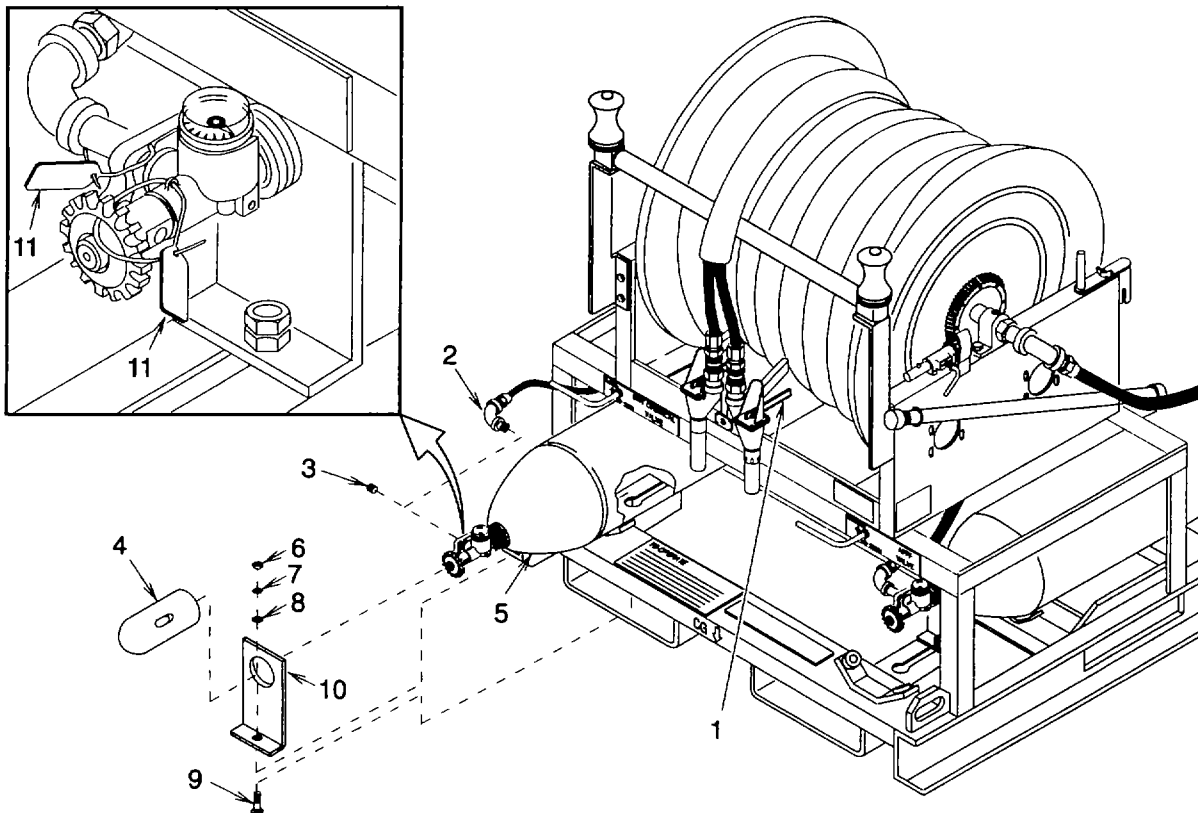

Figure 4-5. Cylinder Removal

WARNING

Trailer must be reasonably level and secure to prevent personal injury from loose cylinder sliding off unit

- (5) Remove nut (6), lock washer (7), flat washer (8), screw (9), and stop plate (10) Discard lock washer

WARNING

Two people are required to lift cylinder to avoid injury to personnel.

- (6) Carefully remove cylinder (5).

b. Installation

- (1) Close cylinder valve if open.

- (a) Turn cylinder valve hand wheel (1) (fig. 4-3) fully counterclockwise (open)
- (b) Close (lower) quick release lever (2) and rotate cross shaft (3) until flat is horizontal
- (c) Turn hand wheel (1) fully clockwise (closed).

- (2) Carefully install full cylinder (5) (fig. 4-5) with gage facing up.
- (3) Slide stop plate (10) onto cylinder (5). Install screw (9), flat washer (8), new lock washer (7), and nut (6)
- (4) Remove shipping cap (4) and store for re-use.
- (5) Remove shipping plug (3), if installed, and store with shipping cap (4) for re-use.
- (6) Install hose assembly (2) onto cylinder (5) valve and tighten securely.
- (7) Check that two strip ties (11) are installed on cylinder (5) valve. If not, install them.
- (8) Check gage for pressure in cylinder (5). Pressure must not be below 1750 psi. (12075 kPa) for normal operation or below that listed in table 4-2 for current temperature.

Table 4-2. Cold Weather Range

-40	= 1575 psi (10868 kPa)
-20	= 1650 psi (11385 kPa)
0	= 1725 psi (11903 kPa)
10	= 1750 psi (12075 kPa)

4-12. NAME PLATES REPLACEMENT.

This task covers **a. Removal** **b. Installation**

INITIAL SETUPTools

General Mechanics Tool Kit, Appendix B, Section III,
item 1

Drill, Appendix B, Section III, item 2

Materials/Parts

Safety Solvent Cleaner, Appendix E, Section II, item 1

Rags, Appendix E, Section II, item 2

Drive Screws (4), Appendix I, item 29

General Safety Instructions**WARNING**

- **Keep safety solvent cleaner away from sparks or flame. The solvent cleaner is flammable and the vapors can be explosive.**
- **Use safety solvent cleaner in a well ventilated area. Wear gloves and eye protection when using solvent cleaner. Repeated or prolonged skin contact or inhalation of solvent cleaner vapors can be toxic.**

NOTE

The ID name plate is secured with drive screws, the remaining name plates are secured with pressure sensitive backing.

a. Removal

(1) ID nameplate.

- (a) Remove four drive screws (1) using a drill bit slightly smaller than the drive screw body. See figure 4-6.
- (b) Remove the ID plate (2) and any remaining drive screw (1) material.

(2) Pressure sensitive backed name plates.

- (a) Carefully pull name plate from equipment.
- (b) Scrape off any remaining name plate material being careful not to scratch the metal surface.

WARNING

- **Keep safety solvent cleaner away from sparks or flame. The solvent cleaner is flammable and the vapors can be explosive.**
- **Use safety solvent cleaner in a well ventilated area. Wear gloves and eye protection when using solvent cleaner. Repeated or prolonged skin contact or inhalation of solvent cleaner vapors can be toxic**

(c) Remove any adhesive remaining on metal surface using safety solvent cleaner and a stiff brush or rag.

b. Installation**(1) ID nameplate**

Position the new ID plate (2) in place and secure with four drive screws (1).

(2) Pressure sensitive backed name plates

- (a) Be sure metal surface is clean and free of any dirt, oils, and residual safety solvent.
- (b) Peel protective backing paper off name plate and carefully place on metal surface Press firmly into place.

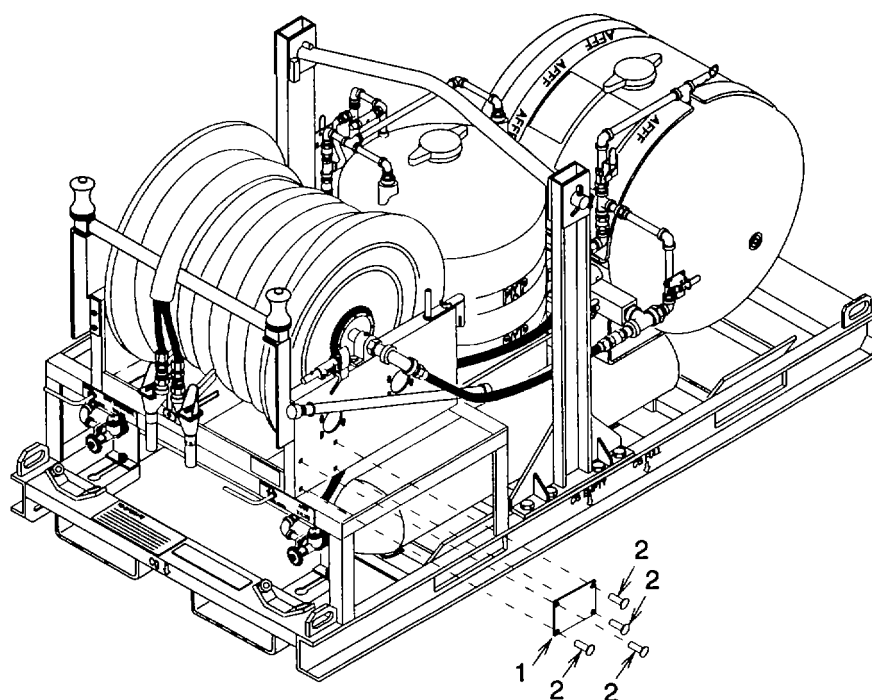

Figure 4-6. ID Plate

4-13. ACCESSORIES REPLACEMENT

This task covers **a. Removal** **b Installation**

INITIAL SETUPTools

General Mechanics Tool Kit, Appendix B, Section III, item 1

Drill, Appendix B, Section III, item 2

Materials/Parts

Lock Washers (2), Appendix H, item 1

Safety Solvent Cleaner, Appendix E, Section II, item 1

Rags, Appendix E, Section II, item 2

Adhesive, Appendix E, Section II, item 3

General Safety Instructions**WARNING**

- **Keep safety solvent cleaner away from sparks or flame. The safety solvent cleaner is flammable and the vapors can be explosive.**
- **Use safety solvent cleaner in a well ventilated area. Wear gloves and eye protection when using solvent cleaner. Repeated or prolonged skin contact or inhalation of solvent cleaner vapors can be toxic.**

a. Removal (See figure 4-7.)

NOTE

**Crank can be found on both the trailer hose reel assembly and the auxiliary hose assembly
The level gage and installation are found only on the trailer hose assembly.**

- (1) Remove wing nut (1), flat washer (2), and crank (3).
- (2) Remove pad (4) if damaged (a) Carefully pull pad (4) from frame (5).
- (b) Scrape off any remaining pad (4) material being careful not to scratch the frame (5) surface

WARNING

- **Keep safety solvent cleaner away from sparks or flame The solvent cleaner is flammable and the vapors can be explosive.**
 - **Use safety solvent cleaner in a well ventilated area Wear gloves and eye protection when using solvent cleaner Repeated or prolonged skin contact or inhalation of solvent cleaner vapors can be toxic.**
- (c) Remove any adhesive remaining on frame (5) surface using safety solvent cleaner and a stiff brush or rag.
 - (d) Be sure frame (5) surface is clean and free of any dirt or oils

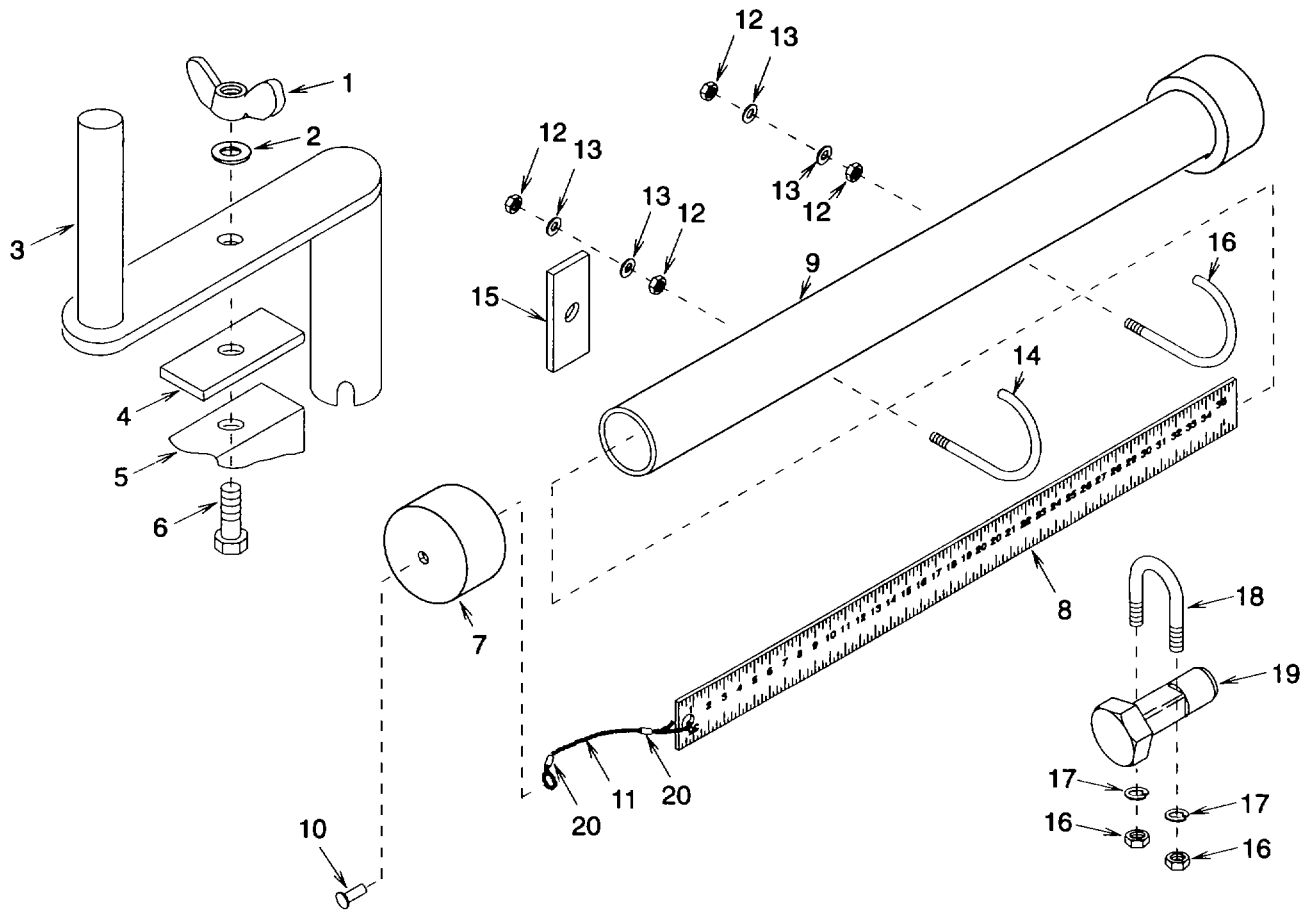

Figure 4-7. Accessories

4-13. ACCESSORIES REPLACEMENT. - continued**NOTE**

Hose reel frame has a threaded hole to hold crank mounting screw.

- (3) If screw (6) is damaged, remove it from frame (5)
- (4) Remove cap (7) and pull gage (8) from tube (9).
- (5) Disassemble liquid measure gage (8).
 - (a) Drill out pop rivet (10) using drill bit slightly smaller than rivet body Discard pop rivet.
 - (b) Remove any remaining pop rivet (10) material from cap (7).
 - (c) Cut cable (11) and remove from gage (8) Discard cable
- (6) Remove four nuts (12), flat washers (13), two hook bolts (14), tube (9), and pad (15).
- (7) Remove two nuts (16), lock washers (17), U-bolt (18), and installation tool (19). Discard lock washers.

b. Installation

NOTE

Crank can be found on both the trailer hose reel assembly and the auxiliary cart. The level gage and the installation tool can be found on the hose reel assembly

- (1) Install installation tool (19) and secure using U-bolt (18), two new lock washers (17), and nuts (16).
- (2) Install tube (9) and secure using two hook bolts (14), four flat washers (13), and nuts (12) Before tightening four nuts, install pad (15) under tube to prevent cap (7) from binding
- (3) Assemble liquid measure gage (8).
 - (a) Push new cable (11) through new cable sleeve (20) and then loop through hole in gage (8) Push cable end back into cable sleeve. Secure by crimping sleeve.
 - (b) Push loose cable (11) end through another new cable sleeve (20). Push cable end back into cable sleeve to form a loop just large enough to fit pop rivet (10) body through Secure by crimping sleeve
 - (c) Secure loose cable (11) end loop to inside of cap (7) using pop rivet (10).
- (4) Insert gage (8) into tube (9) and install cap (7) onto tube
- (5) Install screw (6) into frame (5)
- (6) Install pad (4).
 - (a) Coat mating surfaces of frame (5) and pad (4) with adhesive. Let both surfaces air dry until adhesive is tacky but will not stick to fingers.
 - (b) Carefully attach pad (4) to frame (5). Press into firm contact all over (7) Install crank (3), flat washer (2), and wing nut (1) onto screw (6).

4-14. NOZZLE BRACKET AND QUICK DISCONNECT REPLACEMENT

This task covers **a. Removal** **b Installation**

INITIAL SETUP

Tools

General Mechanics Tool Kit, Appendix B, Section III, item 1

Equipment Condition

Close cylinder valves and relieve system pressure per paragraph 4-11 steps (1) and (2).

Materials/Parts

Lock Washers (2), Appendix H, item 2

Antisieze Tape, Appendix E, Section II, item 4

a. Removal (See figure 4-8)

- (1) Release quick coupling half (1) and disconnect hose assembly (2).
- (2) Pull pin (3) and remove nozzle (4) assembly from bracket (5).
- (3) Remove four screws (6) securing nozzle (4) to tie bar (7)
- (4) Remove nipple (8) and coupler (1) from nozzle (4)
- (5) Remove O Ring(9) from coupler (1).
- (6) Remove two nuts (10), lock washers (11), screws (12), flat washers (13), cable (14), and bracket (5)
Discard lock washers.
- (7) Remove cable (14) from pin (3).

b. Installation

- (1) Assemble new cable (14).
 - (a) Push new cable (14) through new cable sleeve (15) and then loop tightly around pin (3) Push cable end back into cable sleeve Secure by crimping sleeve
 - (b) Push loose cable (14) end through another new cable sleeve (15). Push cable end back into cable sleeve to form a loop just large enough to fit screw (12) body through. Secure by crimping sleeve
- (2) Slip cable (14) onto pin (3)
- (3) Install bracket (5), cable (14), two screws (12), flat washers (13), new lock washers (11), and nuts (10)

4-14. NOZZLE BRACKET AND QUICK DISCONNECT REPLACEMENT - continued.

NOTE

Install coupler onto the AFFF chemical nozzle (holes in tip).

- (4) Wrap nipple (8) and coupler (1) threads with Antlsizee tape and install onto appropriate nozzles (4).
- (5) Install O Ring (9) into coupler (1).
- (6) Install tie bar (7) and four screws (6) onto nozzles (4).
- (7) Install nozzles (4) assembly onto bracket (5) and secure with pin (3).
- (8) Release quick coupling half (1) and connect hoses (2).

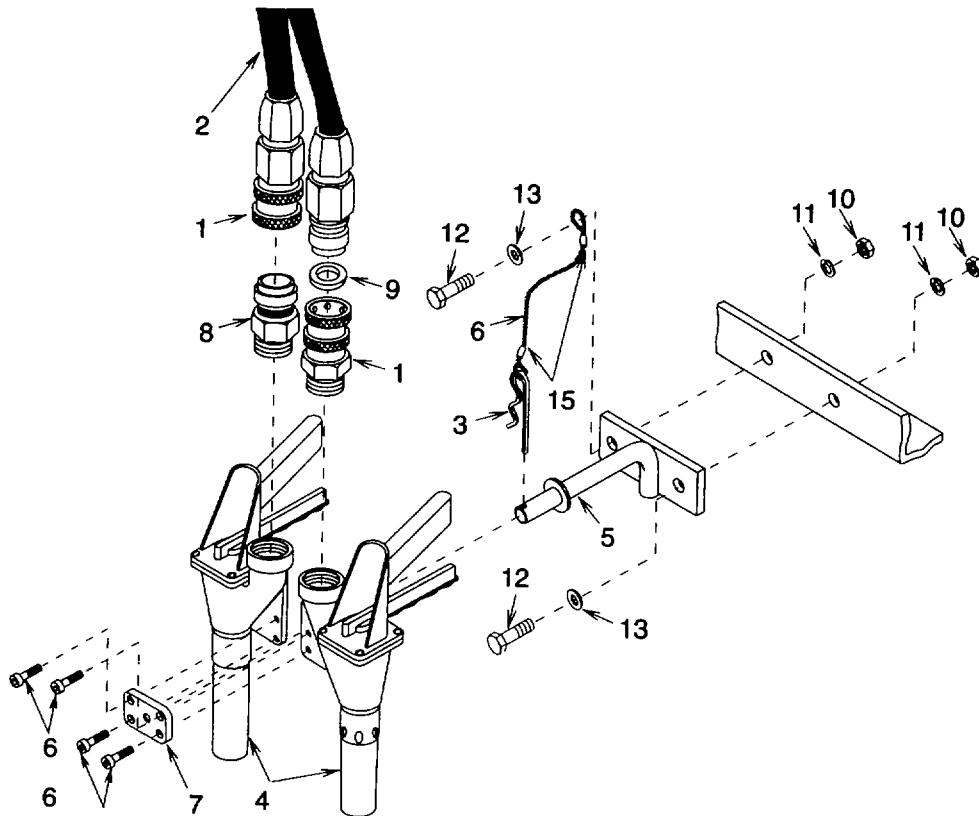

Figure 4-8. Nozzle Bracket and Quick Coupling Half Disconnect

4-15. HOSES REPLACEMENT

This task covers: **a Removal** **b Installation**

INITIAL SETUPTools

General Mechanics Tool Kit, Appendix B, Section III,
item 1

Pipe Wrench, 18 Inch, Appendix B, Section III, item 2

Automotive wrench, 18 inch, Appendix B, Section III,
item 2

Materials/Parts

Antisieze Tape, Appendix E, Section II, item 4

Neoprene Washer, Appendix H, item 28

Equipment Condition

Close cylinder valves and relieve system pressure per
paragraph 4-11 steps (1) and (2).

General Safety Instructions**WARNING**

**Servicing the equipment with the system pressurized
can result in serious personal injury.**

**Discharging nitrogen in an enclosed, unventilated space
can cause suffocation.**

- a. Removal (See figure 4-9.)

WARNING

Servicing the equipment with the system pressurized can result in serious personal injury.

Discharging nitrogen in an enclosed, unventilated space can cause suffocation

NOTE

Check that dry chemical and AFFF discharge ball valves are both closed.

- (1) Remove discharge hose assembly (1) if damaged.
 - (a) Disconnect fitting (2) from hose reel swivel elbow Remove and discard neoprene washer (3)
 - (b) Disconnect fitting (4) from discharge valve elbow.
- (2) Remove system cylinder hose assembly (5) If damaged.
 - (a) Disconnect fitting (6) from system cylinder valve.
 - (b) Disconnect fitting (7) from regulator elbow (8).

4-15. HOSES REPLACEMENT. - continued

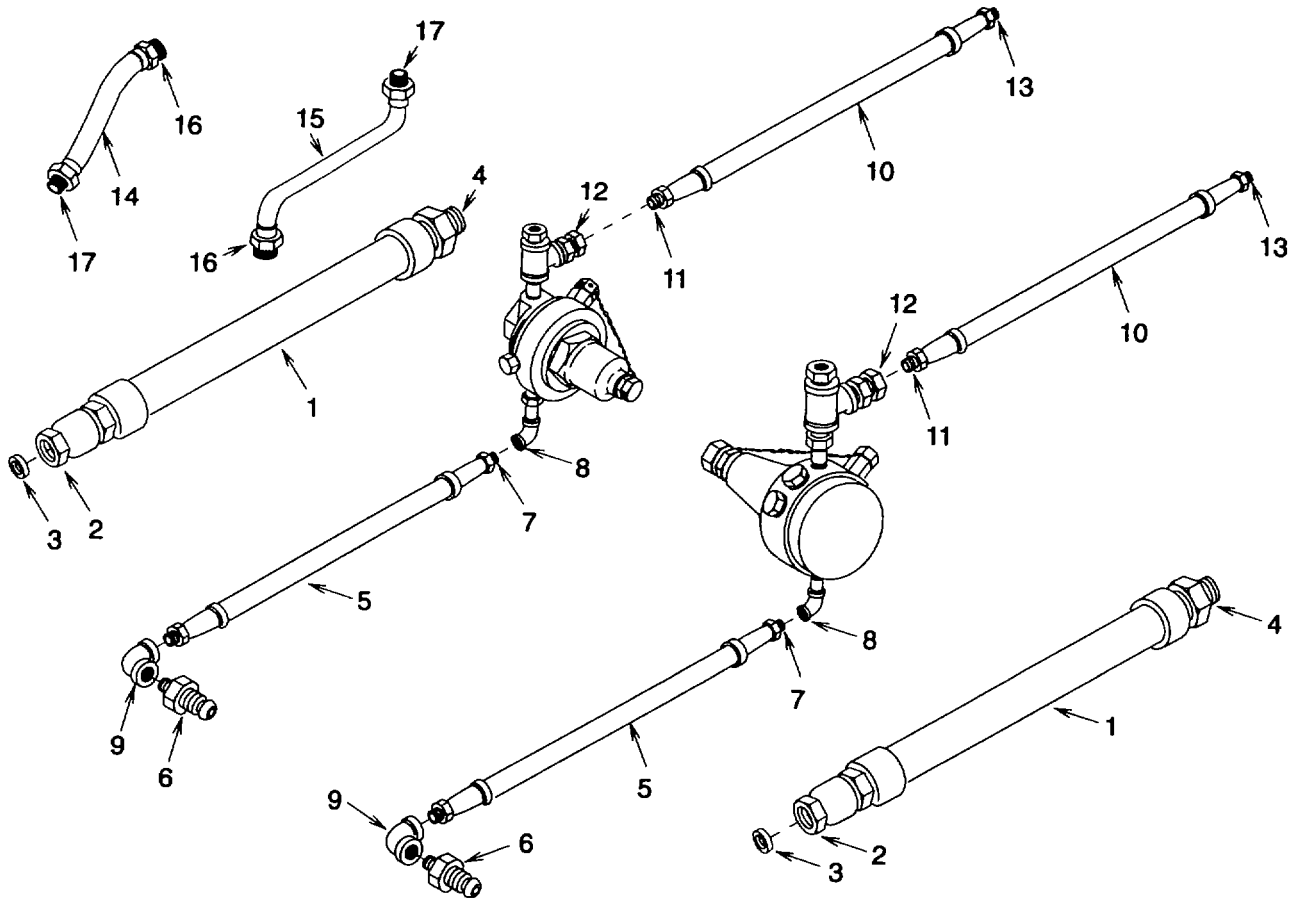

Figure 4-9. Hoses

- (c) Disconnect fitting (6) from elbow (9)
 - (d) Disconnect elbow (9) from hose assembly (5)
- (3) Remove charging hose assembly (10) if damaged.
- (a) Disconnect fitting (11) from regulator swivel adapter (12)
 - (b) Disconnect fitting (13) from tank check valve
- (4) Remove charging bypass hose assembly (14) or discharge bypass hose assembly (15) if damaged
- (a) Disconnect fitting (15) from swivel adapter
 - (b) Disconnect fitting (16) from tee fitting.

b. Installation

- (1) Install discharge hose assembly (1) if removed.
- (a) Wrap Antisieze tape around threaded fitting (4).
 - (b) Connect fitting (4) to discharge valve elbow.
 - (c) Install new neoprene washer (3) into fitting (2).
 - (d) Connect fitting (2) to hose reel swivel elbow.
- (2) Install system cylinder hose assembly (5) If removed
- (a) Connect elbow (9) to hose assembly (5)
 - (b) Connect fitting (6) to elbow (9)
 - (c) Connect fitting (7) to regulator elbow (8).
 - (d) Connect fitting (6) to system cylinder valve.
- (3) Install charging hose assembly (10) if removed.
- (a) Wrap Antisieze tape around threaded fitting (13)
 - (b) Connect fitting (13) to tank check valve.
 - (c) Connect fitting (11) to regulator swivel adapter (12)
- (4) Install charging bypass hose assembly (14) or discharge bypass hose assembly (15) if removed.
- (a) Connect fitting (16) to tee fitting.
 - (b) Connect fitting (15) to swivel adapter.

4-16. REGULATORS REPLACEMENT.

This task covers: **a Removal** **b. Installation**

INITIAL SETUPTools

General Mechanics Tool Kit, Appendix B, Section III, item 1

Pipe Wrench, 10 inch, Appendix B, Section III, item 2

Materials/Parts

Antisieze Tape, Appendix E, Section II, item 4

Lock Washers (2), Appendix H, item 3

Equipment Condition:

Close cylinder valves and relieve system pressure per paragraph 4-11 steps (1) and (2).

General Safety Instructions**WARNING**

Servicing the equipment with the system pressurized can result in serious personal injury.

Discharging nitrogen in an enclosed, un-ventilated space can cause suffocation.

WARNING

Servicing the equipment with the system pressurized can result in serious personal injury.

Discharging nitrogen in an enclosed, unventilated space can cause suffocation.

a. Removal (See figure4-10.)

- (1) Disconnect fitting (1) from swivel adapter (2).
- (2) Disconnect fitting (3) from cylinder valve.
- (3) Remove screw (4), lock washer (5) and regulator (6) assembly
- (4) Disconnect fitting (7) from elbow (8).
- (5) Disconnect elbow (8) from nipple (9).
- (6) Dry chemical system only:
 - (a) Disconnect nipple (9) from bushing (10).
 - (b) Disconnect bushing (10) from regulator (6)
- (7) AFFF system only:

Disconnect nipple (9) from regulator (6).

- (8) Disconnect swivel adapter (2) from tee fitting (11).
- (9) Disconnect plug (12) from tee fitting (11)
- (10) Dry chemical system only:
 Disconnect tee fitting (11) from nipple (13).
- (11) AFFF system only.
 - (a) Disconnect tee fitting (11) from bushing (14)
 - (b) Disconnect bushing (14) from nipple (13)
- (12) Disconnect nipple (13) from regulator (6).

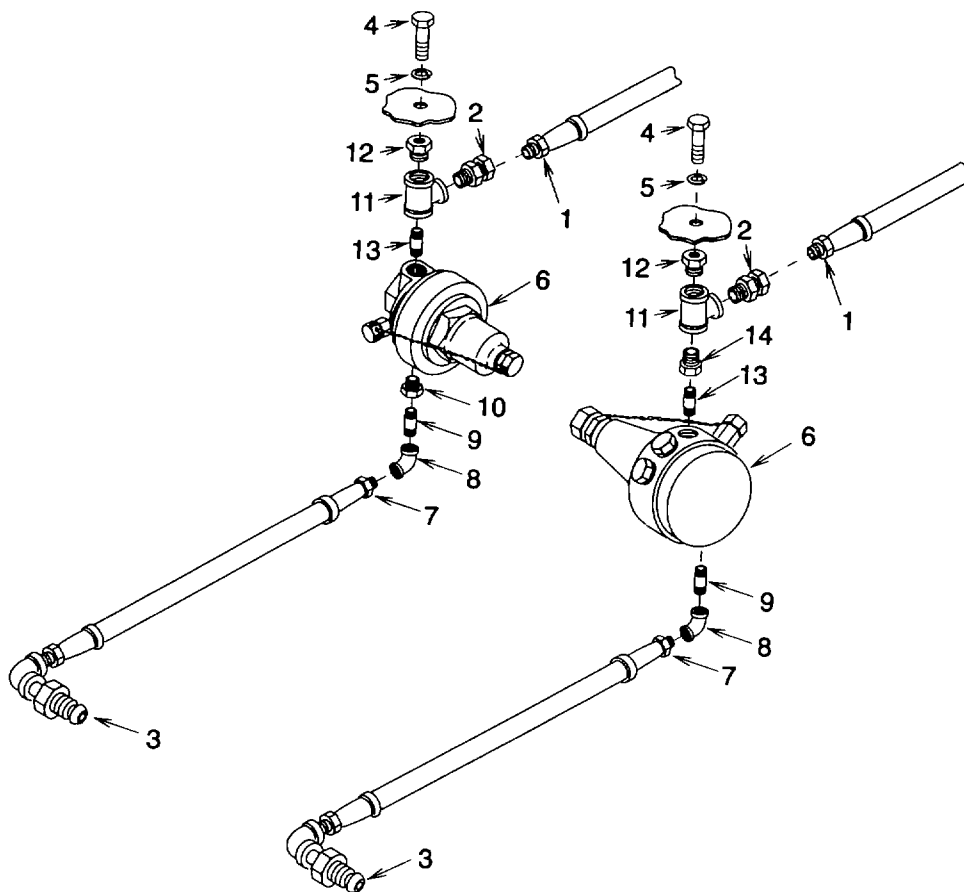

Figure 4-10. Regulators

4-16 REGULATORS REPLACEMENT - continuedb. Installation

- (1) Wrap Antisieze tape around nipple (13) threads (both ends) and connect to regulator (6)
- (2) Dry chemical system only-
 - Connect tee fitting (11) to nipple (13)
- (3) AFFF system only
 - (a) Connect bushing (14) to nipple (13)
 - (b) Wrap antisieze tape around bushing (14) threads and connect to tee fitting (11)
- (4) Wrap antisieze tape around plug (12) threads and connect to tee fitting (11).
- (5) Wrap antisieze tape around swivel adapter (2) threads and connect to tee fitting (11).
- (6) Dry chemical system only
 - (a) Wrap antisieze tape around bushing (10) threads and connect to regulator (6)
 - (b) Wrap antisieze tape around nipple (9) threads and connect to bushing (10)
- (7) AFFF system only
 - Wrap antisieze tape around nipple (9) threads and connect to regulator (6)
- (8) Wrap antisieze tape around nipple (9) threads and connect to elbow (8)
- (9) Wrap antisieze tape around fitting (7) threads and connect to elbow (8)
- (10) Install regulator (6) assembly, lock washer (5), and screw (4)
- (11) Connect fitting (3) to cylinder valve
- (12) Connect fitting (1) to swivel adapter (2).

4-17. FIRE HOSE REPLACEMENT AND REPAIR

This task covers:

a. Removal b. Disassembly c. Repair d. Assembly e. Installation

INITIAL SETUP:Tools

General Mechanics Tool Kit, Appendix B, Section III, item 1

Multimeter, Appendix B, Section III, item 2

Vise, Appendix B, Section III, item 2

Hacksaw, Appendix B, Section HI, item 2

Hose Fitting Installation Tool, Appendix B, Section III, Item 4

Materials/Parts

Antisieze Tape, Appendix E, Section II, item 4

Silicone Grease, Appendix E, Section II, item 10

Gasket, Appendix H, item 18

General Safety Instructions**WARNING**

Servicing the equipment with the system pressurized can result In serious personal injury

Discharging nitrogen in an enclosed, unventilated space can cause suffocation.

Operating without the internal grounding wire In contact with the hose fittings can result in severe static shock

Equipment Condition:

Remove hose fitting installation tool per paragraph 4-13.

Close cylinder valves and relieve system pressure per paragraph 4-11 steps (1) and (2)

NOTE

Disassemble equipment only to extent necessary for repair

- a. Removal (See Figure 4-11.)

WARNING

Servicing the equipment with the system pressurized can result In serious personal injury

Discharging nitrogen in an enclosed, unventilated space can cause suffocation.

- (1) Disconnect fire hose (1) from nozzles (2).
- (2) Release rewind brake assembly.
- (3) Pull fire hose (1) fully from hose reel.
- (4) Tag and disconnect fire hose (1) fittings from hose reel distributor (3) connections

4-17 FIRE HOSE REPLACEMENT AND REPAIR. - continued

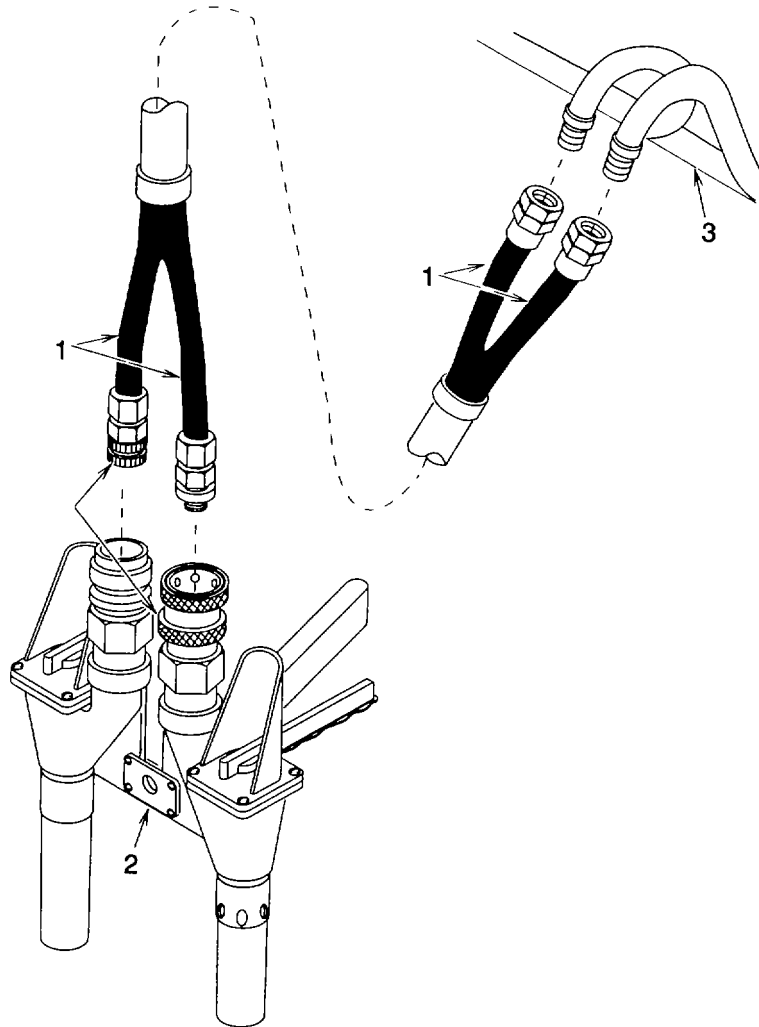

Figure 4-11. Hose Removal

b. Disassembly (See figure 4-12)

CAUTION

A final repaired hose length less than 140 feet can affect operational readiness.

- (1) Place ferrule (1) in a vice
- (2) Remove nipple (2) and coupler (3) as required.
- (3) Remove pre-formed packing (4) from coupler (3)
- (4) Use installation tool (5) to remove coupling (6) from ferrule (1).

- (5) Remove hose (7) from ferrule (1) and remove ferrule from vice.

NOTE

Hose ends must be kept even for proper installation

- (6) Repeat steps (1) through (5) for disassembly of second hose end
- (7) Remove and discard gasket (8).
- (8) Place ferrule (9) in vice Allow coupling (10) to extend beyond face of vice

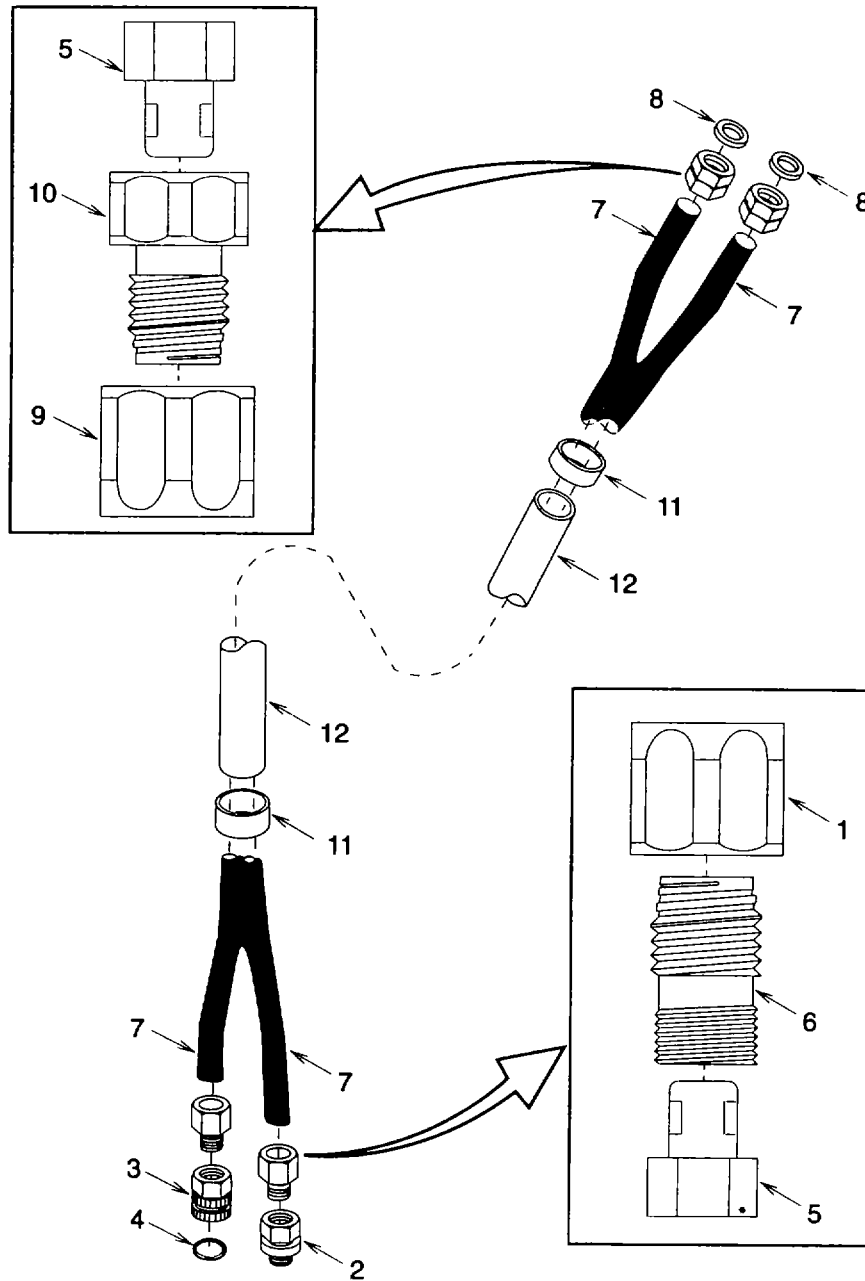

Figure 4-12. Hose Assembly

4-17 FIRE HOSE REPLACEMENT AND REPAIR. - continued

- (9) Use installation tool (5) to remove coupling (10) from ferrule (9).
- (10) Remove hose (7) from ferrule (9) and remove ferrule from vice.
- (11) Repeat steps (7) through (10) for disassembly of second hose end.
- (12) Carefully slip retainer bands (11) and hose Jacket (12) off hoses (7).

c. Repair**NOTE**

The straight adapter and pipe coupling are supplied as complete assemblies consisting of one each coupling and ferrule.

Replace all damaged or defective parts.

d. Assembly (See figure 4-12.)

- (1) If old hoses (7) are to be re-used, cut off any damaged portion of hose end.

NOTE

Be sure hoses are identical length after replacing a damaged fitting by removing and reinstalling adjoining fitting as well. This will assure proper installation to hose reel or nozzle. Hose end must be cut neat and square.

- (2) Cut ends of hoses (7) neat and square to equal lengths.
- (3) Carefully slip hose jacket (12) over hoses (7).
- (4) Allow approximately 20 inches (51 cm) of hose (7) to extend from end of hose jacket (12) and secure with retainer bands (11).

WARNING

Operating without the internal grounding wire in contact with the hose fittings can result in severe static shock.

- (5) Pull a 1/4 inch (0.64 centimeter) length of grounding wire from under hose (7) cover and fold back over outside of hose.
- (6) Install ferrules (1) and (9) onto hose (7) ends turning counterclockwise until the hose bottoms against ferrule end.
- (7) Lubricate the taper end of couplings (6) and (10) and insert into ferrules (1) and (9). Place ferrules in vise. Using insertion tool (5), turn clockwise until coupling bottoms against ferrule.
- (8) Wrap antisieze tape around hose coupling (6) threads and install nipple (2) and coupler (3). Tighten as required (9) Install pre-formed packing (4) into coupler (3).

- (10) Check continuity between nipple (2) and coupling (10) If contumely exists, tag and identify coupling as AFFF hose.
- (11) Check continuity between coupler (3) and coupling (10) If continuity exists, tag and identify coupling as dry chemical hose
- (12) Install new gaskets (8) into couplings (10).

e. Installation

CAUTION

Fire hose must be connected to the right hose reel distributor fitting or damage to the nozzles can result.

- (1) Check to be sure gaskets (8) (fig 4-12) are in place then connect fire hose (1) (fig 4-11) to hose reel distributor (3) connections with dry chemical hose connected to roadside distributor connection

NOTE

Dry chemical hose must connect to roadside distributor fitting

- (2) Rewind fire hose (1) onto hose reel and secure rewind brake assembly.
- (3) Connect fire hose (1) to nozzles (2).

4-18. HOSE ROLLER ASSEMBLY REPLACEMENT.

This task covers:

- a. Removal b. Disassembly c. Repair d. Assembly e. Installation**
-

INITIAL SETUP:

Tools

General Mechanics Tool Kit, Appendix B, Section III, item 1

Materials/Parts

Lock Washers (4), Appendix H, item 2
 Lock Washers (2), Appendix H, item 3

a. Removal (See figure 4-13)

Remove four nuts (1), lock washers (2), screws (3), flat washers (4), and bracket (5).

b. Disassembly (See figure 4-14)

- (1) Remove two hole plugs (1)
- (2) Remove two nuts (2), lock washers (3), and screws (4)
- (3) Remove two spools (5) and bushings (6).
- (4) Remove two pedestals (7), bearings (8), one tube (9), and axle (10)

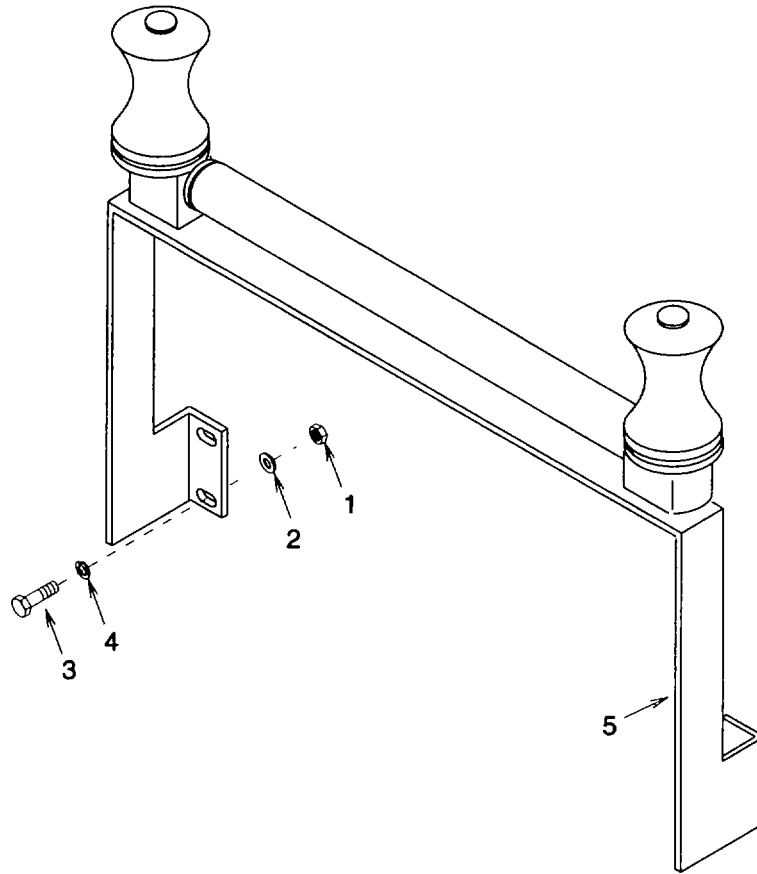

Figure 4-13. Hose Roller Assembly Removal

c. Repair

Repair is by replacement of defective or damaged components

d. Assembly (See figure 4-14.)

- (1) Install one pedestal (7), spool (5), bushing (6) screw (4) new lock washer (3), and nut (2).
- (2) Assemble tube (9), two bearings (8), axle (10), and remaining pedestal (7). Insert axle into pedestal installed on bracket 11
- (3) Install spool (5) and bushing (6) onto pedestal (7) and secure to bracket (11) using screw (4), new lock washer (3), and nut (2)
- (4) Install two hole plugs (1).

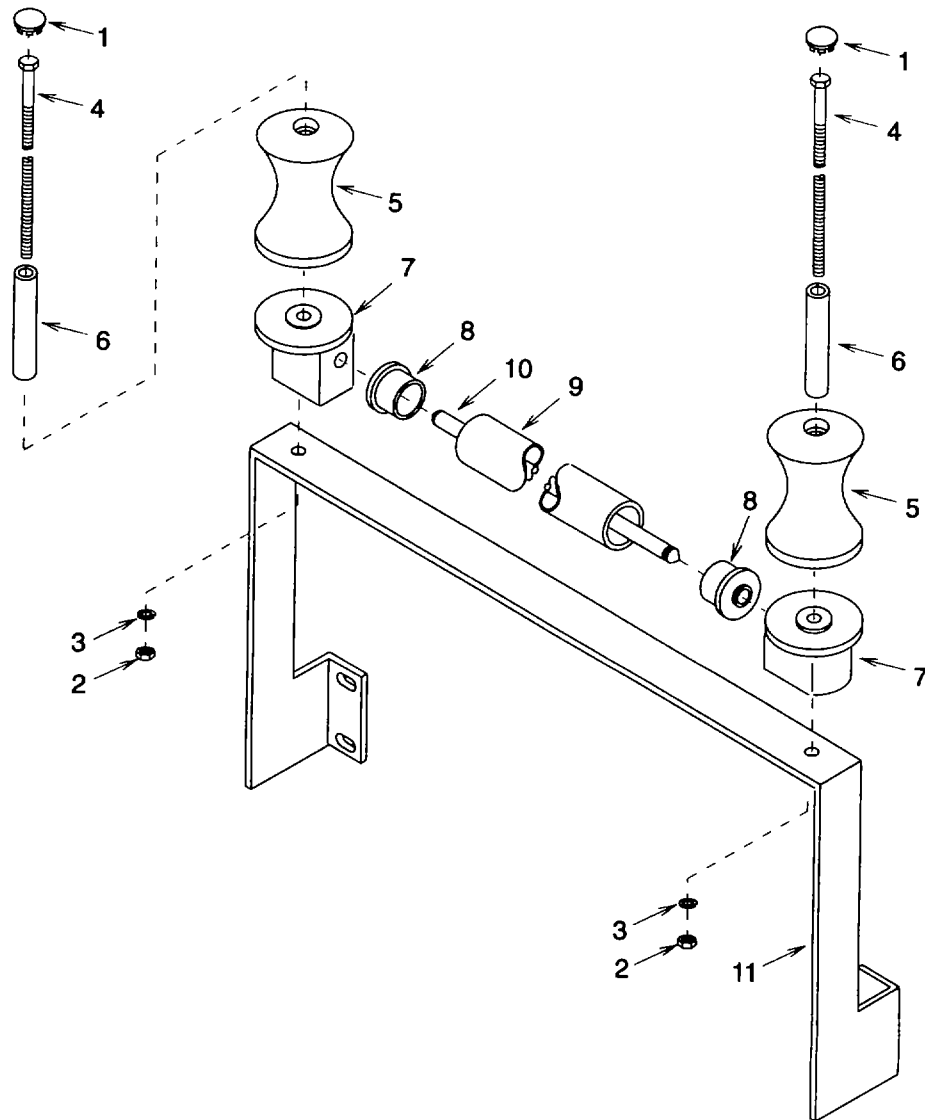

Figure 4-14. Hose Roller Assembly

e. Installation (See figure4-13.)

NOTE

Bracket must slip under fire hose when installed.

Install bracket (5), four screws (3), flat washers (4), new lock washers (2), and nuts (1).

4-19 HOSE REEL ASSEMBLY REPAIR AND REPLACEMENT

This task covers:

- a. Removal b. Disassembly c. Repair d. Assembly e. Installation**

INITIAL SETUP:

Tools

General Mechanics Tool Kit, Appendix B, Section III, Item 1

Equipment Condition

Remove installation tool from trailer mounted hose reel (para 4-13).

Remove gage case from trailer mounted hose reel (para 4-13)

Remove hand crank (para 4-13).

Remove nozzles and bracket (para 4-14).

Remove fire hose (para 4-17).

Remove hose roller assembly from trailer mounted hose reel (para 4-18).

Remove nozzle bracket (para 4-14)

Remove discharge hoses (para 4-15 and 4-31).

Remove rewind brake assembly (para 4-20)

Materials/Parts

Lock Washers (4) for trailer mounted extinguisher assembly or (8) for auxiliary mobile hose reel cart, Appendix H, item 2

Lock Nuts (12), Appendix H, item 13

Preformed Packing (2), Appendix H, item 19

Preformed Packing (2), Appendix H, item 20

Lock Washers (4), Appendix H, item 2

Antisieze Tape, Appendix E, Section II, item 4

Grease, Appendix E, Section II, item 11

Sand Paper (100 Grit), Appendix E, Section II, item 13

Personnel Required

Two

General Safety Instructions

WARNING

Lifting the hose reel assembly by yourself can result in serious personal injury.

a. Removal (See figure 4-15.)

- (1) Remove four nuts (1), lock washers (2), screws (3), and flat washers (4) for trailer mounted extinguisher assembly. Discard lock washers.
- (2) Remove two nuts (5), flat washers (6), and J-bolts (7) for auxiliary mobile hose reel cart.
- (3) Remove eight nuts (8), lock washers (9), and four U-bolts (10) for auxiliary mobile hose reel cart. Discard lock washers.

WARNING

Lifting the hose reel assembly by yourself can result in serious personal injury.

- (4) Using two personnel, carefully remove frame (11) from unit or cart as applicable.

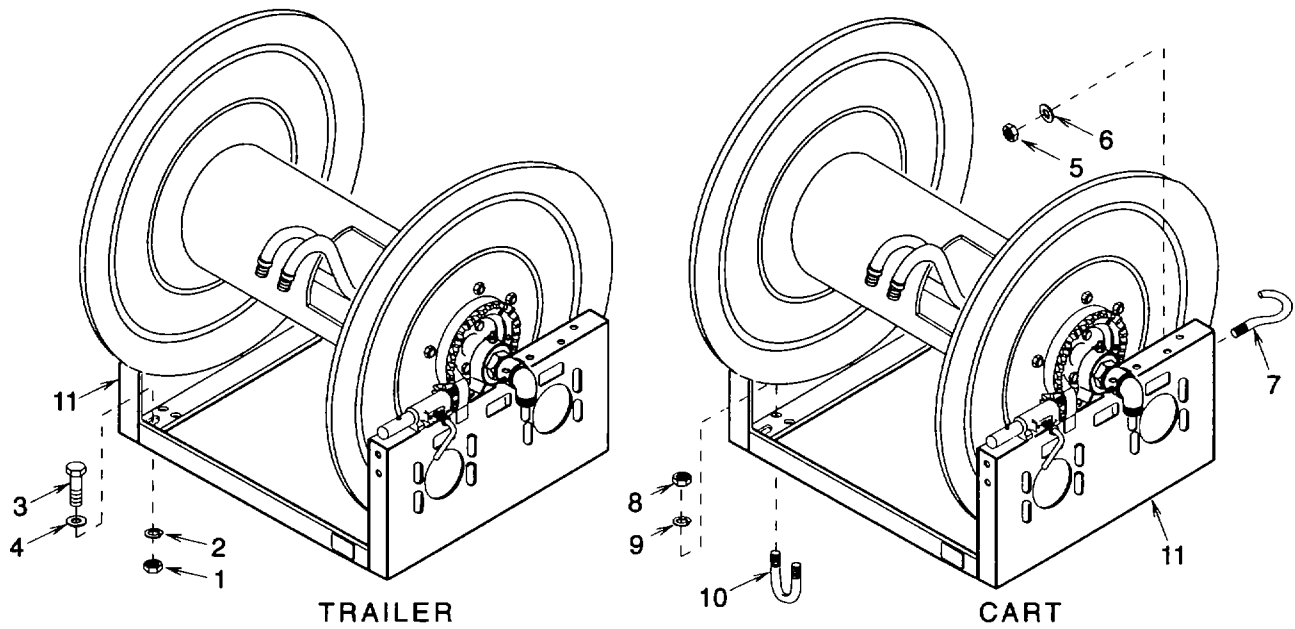

Figure 4-15. Hose Reel Assembly

b. Disassembly (See figure 4-16)

- (1) Disconnect two union tailpieces (1) from distributor (2).
- (2) Remove setscrew (3), lubrication fitting (4), and 30 ball bearings (5).
- (3) Carefully separate elbow (6) and union tailpiece (1).
- (4) Remove preformed packing (7) and (8). Discard preformed packing.
- (5) Remove four nuts (9), lock washers (10), eight flat washers (11), and four screws (12). Using sand paper, carefully remove paint from distributor (2) and slip two bearings (13) off. Discard lock washers
- (6) Remove eight screws (14), and gear (15)
- (7) Remove eight screws (16), 12 lock nuts (17), two discs (18), six spacers (19), distributor (2) flange (20), and spool (21). Discard lock nuts

c. Repair

Repairs are limited to replacement of individual components.

4-19. HOSE REEL ASSEMBLY REPAIR AND REPLACEMENT. - continued

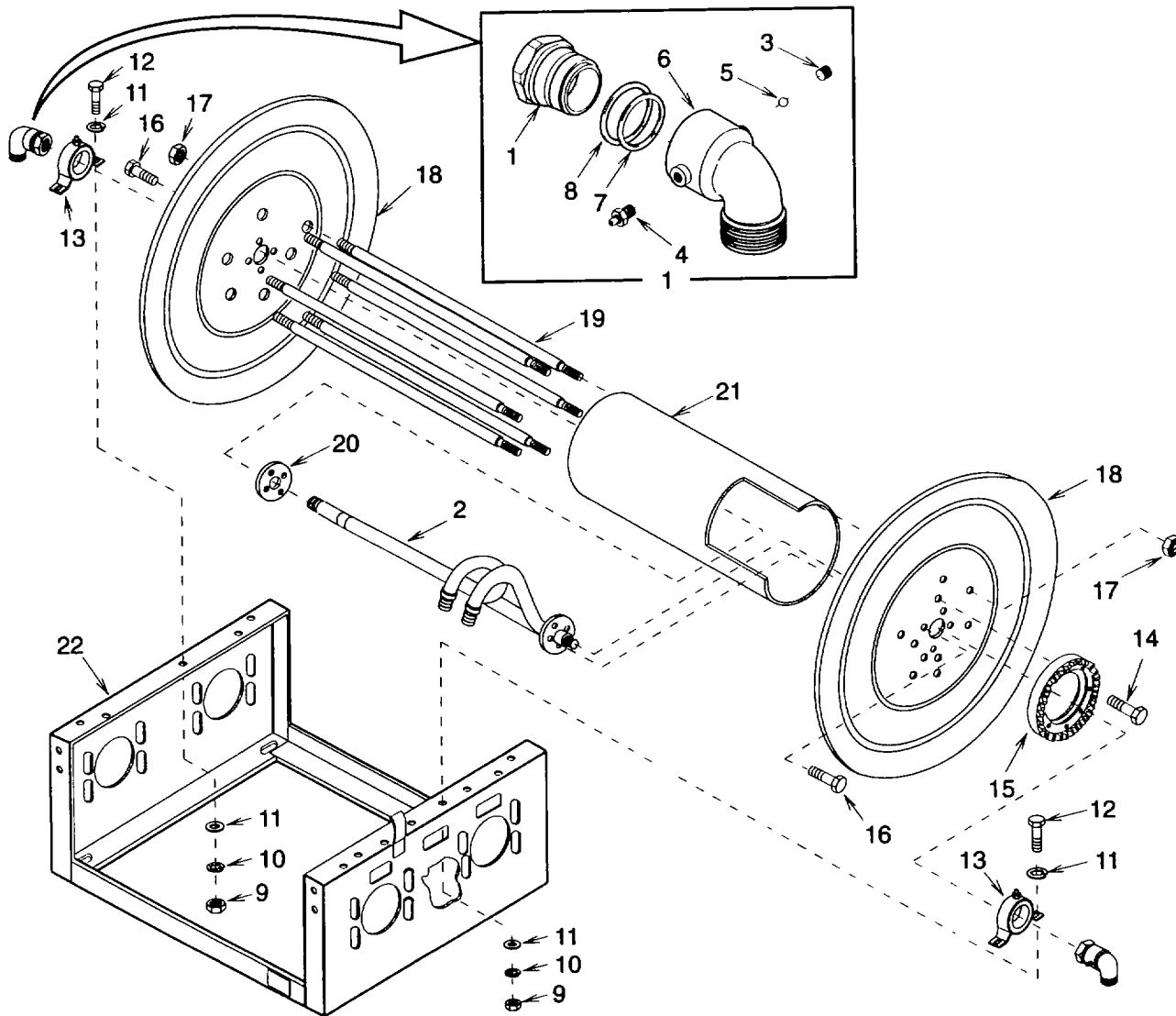

Figure 4-16. Drum Assembly

d. Assembly (See figure 4-16.)

- (1) Install flange (20) and four screws (16) onto disc (18)
- (2) Install six spacers (19) and nuts (17) onto disc (18).
- (3) Slide spool (21) over spacers (19). Notched end on spool to face away from disc (18)
- (4) Carefully install distributor (2) through spool (21) and into flange (20).
- (5) Install second disc (18) and six nuts (17) onto spacers (19).
- (6) Install four screws (16).

- (7) Install gear (15) and eight screws (14) onto disc (18).
 - (8) Carefully slide bearings (13) onto distributor (2) ends. Place spool (21) assembly onto frame (22) and align bearing mounting holes.
 - (9) Install four screws (12), eight flat washers (11), four new lock washers (10), and nuts (9)
 - (10) Lubricate new preformed packing (7) and (8) with grease and install onto tailpiece (1).
 - (11) Carefully slip tailpiece (1) into elbow (6).
 - (12) Install lubrication fitting (4)
 - (13) Install 30 ball bearings (5)
 - (14) With setscrew (3) removed, lubricate with grease through lubrication fitting (4) until grease comes out open hole. Install setscrew.
 - (15) Wrap antisieze tape around distributor (2) threaded ends and connect two tail pieces (1)
- e. Installation (See figure 4-15.)

WARNING

Lifting the hose reel assembly by yourself can result in serious personal injury.

- (1) Using two personnel, carefully place frame (11) on unit or cart as applicable and align mounting holes.
- (2) Install four screws (3), flat washers (4), new lock washers (2), and nuts (1) for trailer mounted extinguisher assembly.
- (3) Install four U-bolts (10), eight new lock washers (9), and nuts (8) for auxiliary mobile hose reel cart.
- (4) Install two J-bolts (7), flat washers (6), and nuts (5) for auxiliary mobile hose reel cart.
- (5) Install rewind brake assembly per paragraph 4-20.
- (6) Install hose roller assembly per paragraph 4-18 for trailer mounted extinguisher assembly (7) Install fire hose per paragraph 4-17 (8) Install bracket and nozzles per paragraph 4-14 (9) Install installation tool per paragraph 4-13 for trailer mounted extinguisher assembly.
- (10) Install gage case from trailer mounted hose reel per paragraph 4-13 for trailer mounted extinguisher assembly (11) Install crank per paragraph 4-13.
- (12) Install discharge hoses per paragraph 4-15 and 4-31

4-20. REWIND BRAKE ASSEMBLY REPLACEMENT.

This task covers: a Removal b Installation

INITIAL SETUP

Tools

Materials/Parts

General Mechanics Tool Kit, Appendix B, Section III,
Item 1

Lock Washers (2), Appendix H, item 2

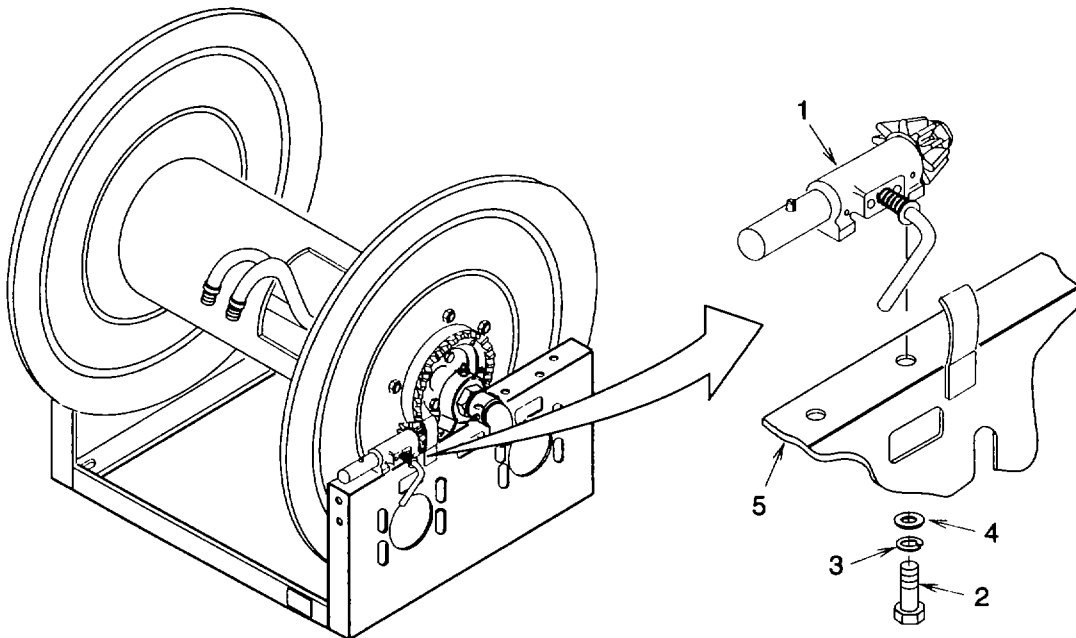

Figure 4-17. Rewind Brake Assembly

a. Removal

- (1) Release rewind brake assembly (1).
- (2) Remove two screws (2), lock washers (3), flat washers (4), and brake assembly (1)

b. Installation

- (1) Position rewind brake assembly (1) onto hose reel frame (5) and align mounting holes.
- (2) Secure using two screws (2), new lock washers (3), and flat washers (4)

NOTE

Fire hose must be pulled off reel quickly when needed without releasing brake

- (3) Loosen brake assembly (1).

4-21. LIFT BAR REPAIR.

This task covers:**a. Removal****b. Repair****c. Installation**

INITIAL SETUP:ToolsMaterials/PartsGeneral Mechanics Tool Kit, Appendix B, Section III,
item 1

Lock Washers (8), Appendix H, item 3

Cotter Pins (2), Appendix H, item 4

a. Removal (See figure 4-18.)

Remove eight nuts (1), lock washers (2), beveled washers (3), screws (4), and flat washers (5). Carefully lift posts (6) off unit. Discard lock washers

b. Repair**NOTE****Repair is limited to replacement of defective or damaged components only**

- (1) Remove cotter pins (7). Carefully remove posts (6) from lift bar (8). Discard cotter pins.
- (2) Insert lift bar (8) into posts (6) and install new cotter pins (7)

c. Installation

Carefully place posts (6) onto unit and align mounting holes. Install eight screws (4), flat washers (5), beveled washers (3), new lock washers (2), and nuts (1).

4-21 LIFT BAR REPAIR. - continued

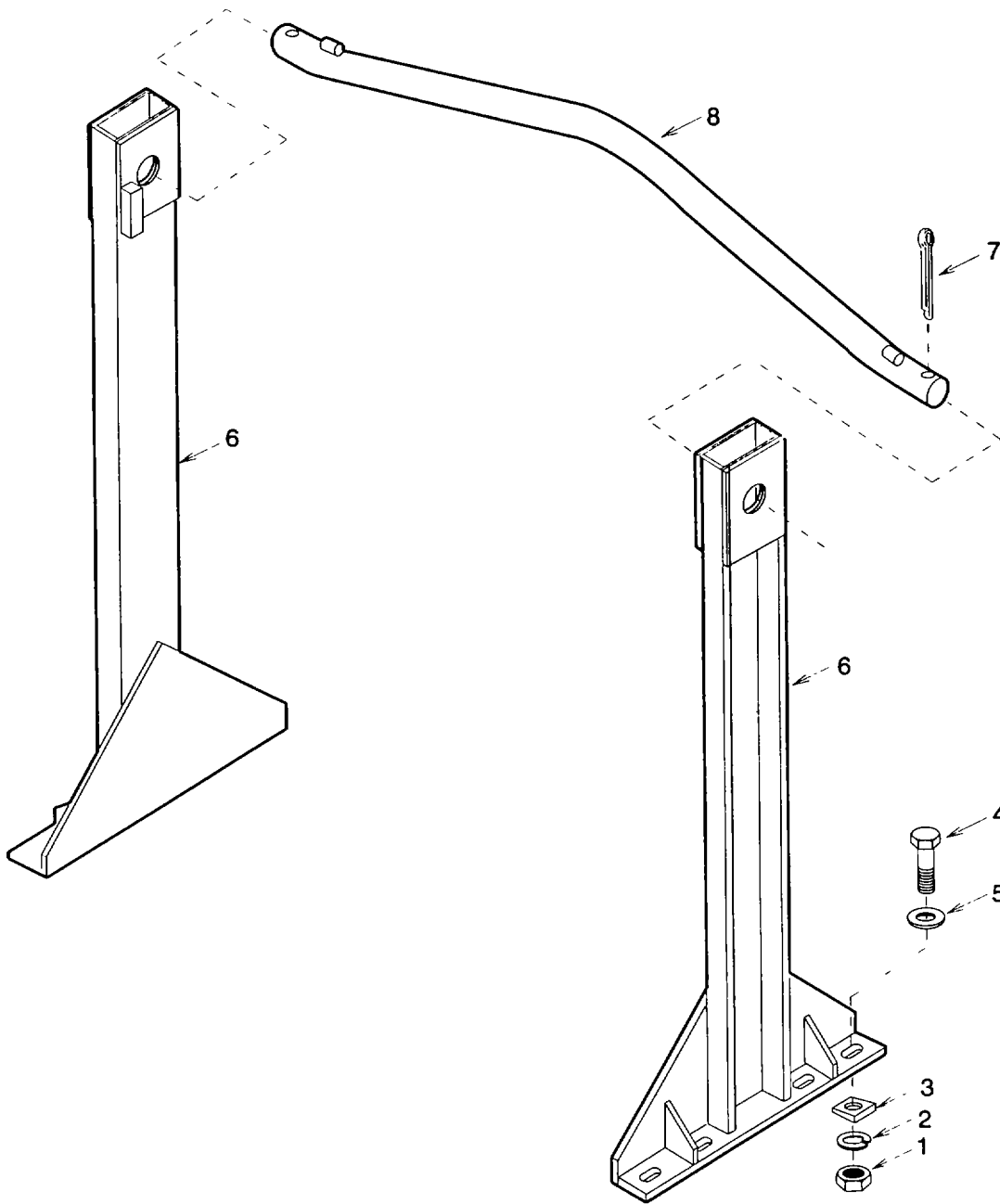

Figure 4-18. Lift Bar Assembly

4-22. DRY CHEMICAL TANK REPLACEMENT AND REPAIR.

This task covers:

- a. Removal b. Disassembly c. Repair d. Assembly e. Installation**
-

INITIAL SETUP:

Tools

General Mechanics Tool Kit, Appendix B, Section III, item 1

Tank Lifting Tool, Appendix B, Section III, item 6

Lifting Device (Two Ton Capacity)

Equipment Condition:

Set parking brakes and lower jacks (para 4-29).

Remove lift bar (para 4-21)

Remove discharge hose and charging hose (para 4-15 steps (1) and (3)).

Remove cylinders (para 4-11).

Materials/Parts

antiseize Tape, Appendix E, Section II, item 4

Spring Pin, Appendix H, Item 5

Strip Ties (2), Appendix H, item 29

General Safety Instructions

WARNING

Tank can swing while suspended from a lifting device causing injury to personnel and/or damage to equipment.

a. Removal (See figure 4-19.)

(1) Remove spring pin (1) and rod (2) from valve (3). Discard spring pin.

(2) Remove four nuts (4), lock washers (5), screws (6), and flat washers (7) Discard lock washers.

WARNING

Tank can swing while suspended from a lifting device causing injury to personnel and/or damage to equipment

CAUTION

Piping is exposed extending outside of tank and can be damaged when lifting.

(3) Remove cap (8) and place tank lifting tool (9) onto tank (10) fill collar. Install cap.

(4) Attach lifting device to tank lifting tool (9). Secure tank (10) from swinging and carefully lift Lower tank onto level ground or suitable work area floor.

(5) Remove cap (8) and tank lifting tool (9) Install cap and hand tighten only.

4-22 DRY CHEMICAL TANK REPLACEMENT AND REPAIR - continued

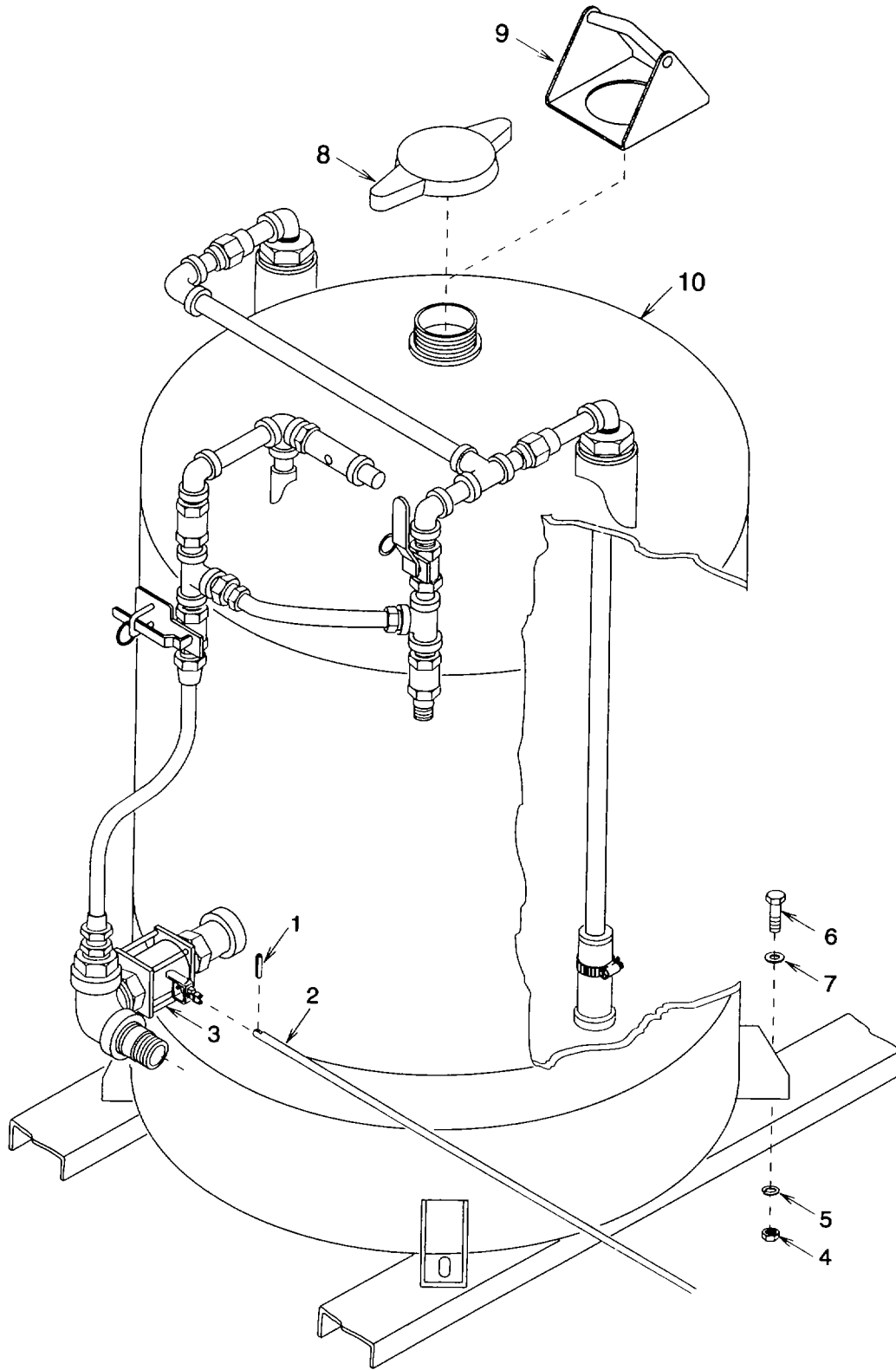

Figure 4-19. Dry Chemical Tank Removal

b. Disassembly (See figure 4-20.)

- (1) Remove fill cap (1).
- (2) Empty all dry chemical from tank (2).
- (3) Break two strip ties (3) and pull two retaining clips (4).
- (4) Remove two screws (5) and ball valve mounting bracket (6).
- (5) Remove two screws (5) and ball valve mounting bracket (7).
- (6) Slip cable (8) off each retaining clip (4).
- (7) Cut cable (8) from valve mounting brackets (6) and (7). Discard cables
- (8) Disconnect hose assembly (9) from swivel fitting (10) then from tee fitting (11).
- (9) Disconnect hose assembly (12) from swivel fitting (13) then from ball valve (14)
- (10) Separate two union (15) halves.
- (11) Disconnect check valve (16), nipple (17), tee fitting (11), nipple (18), ball valve (19), nipple (20), elbow (21), and nipple (22).
- (12) Disconnect union (15) half, nipple (23), elbow (24), nipple (25), tee fitting (26), nipple (27), and union (15) half.
- (13) Disconnect union (15) half, nipple (28), elbow (29), and reducer (30).
- (14) Disconnect union (15) half, nipple (31), elbow (32), and reducer (33).
- (15) Disconnect dip tube (34) from reducer (33). Loosen and remove hose clamp (35) then remove rubber sleeve (36).
- (16) Disconnect ball valve (14), nipple (37), swivel fitting (10), tee fitting (38), nipple (39), check valve (40), nipple (41), elbow (42), nipple (43), pressure relief valve (44), elbow tee (45), and nipple (46)
- (17) Disconnect swivel fitting (13), reducer (47), elbow tee (48), nipple (49), valve (50), and nipple (51).

c. Repair

Repair is limited to replacement of defective or damaged components only.

4-22 DRY CHEMICAL TANK REPLACEMENT AND REPAIR - continued

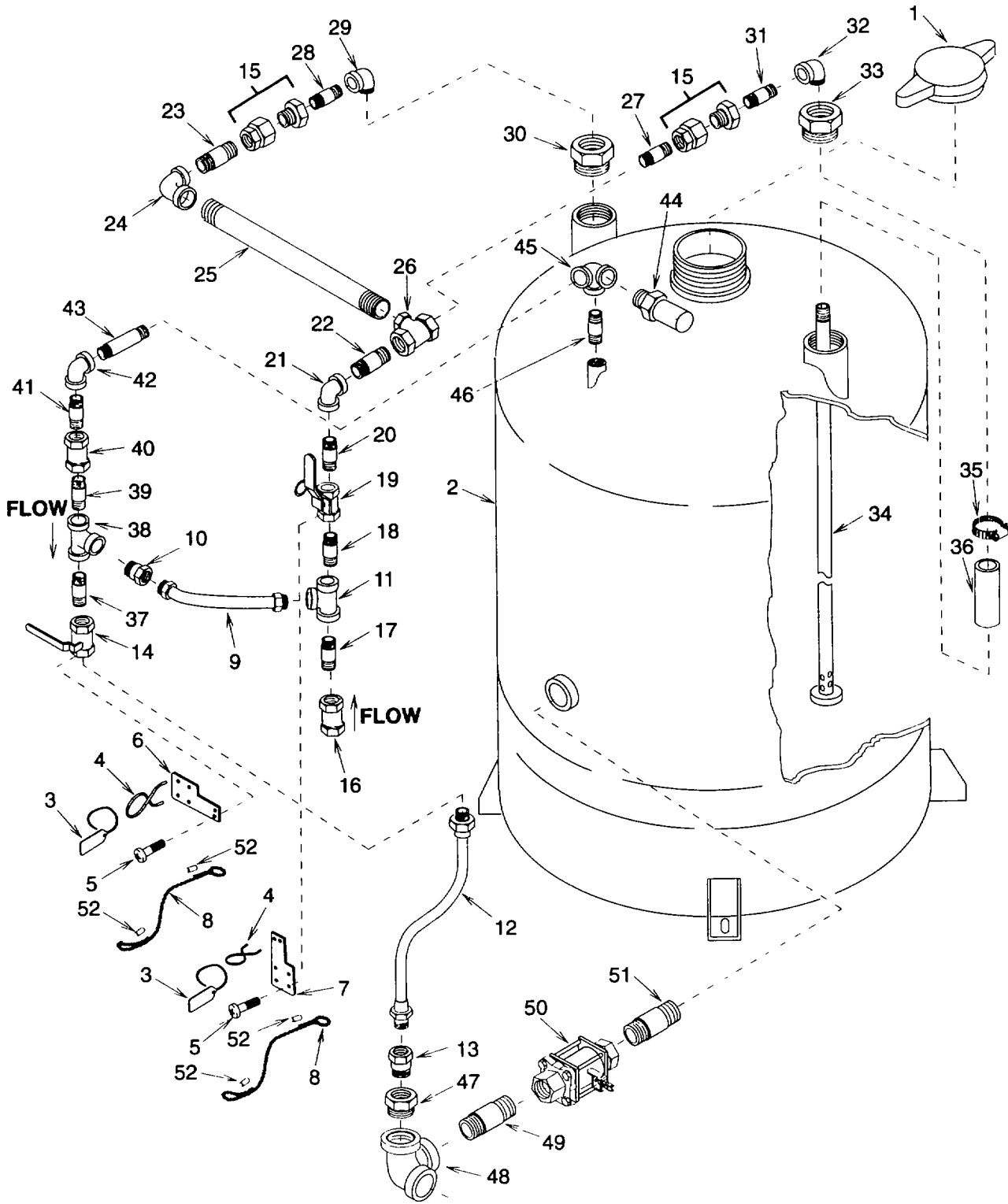

Figure 4-20. Dry Chemical Tank Assembly

d. Assembly

- (1) Wrap antisieze tape around threaded ends of nipples (51) (fig. 4-20) and (49) and male ends of reducer (47) and swivel fitting (13). Connect nipple (51), valve (50), nipple (49), elbow tee (48), reducer (47), and swivel fitting (13).
- (2) Wrap antisieze tape around threaded ends of nipples (46), (43), (41), (39), (37) and male ends of pressure relief valve (44) and swivel fitting (10). Connect nipple (46), elbow tee (45), pressure relief valve (44), nipple (43), elbow (42), nipple (41), check valve (40) with flow arrow pointed away from nipple (41), nipple (39), tee fitting (38), swivel fitting (10), nipple (37), and ball valve (14)

CAUTION

If the gas tube is not assembled to the dimensions given, equipment failure can result.

- (3) Slip rubber sleeve (1) (fig. 4-21) down onto dip tube (2) 1 inch (2.5 centimeters) away from end plate (3). Secure with hose clamp (4) positioned 3 1/2 inches (8.9 centimeters) away from end plate (3).

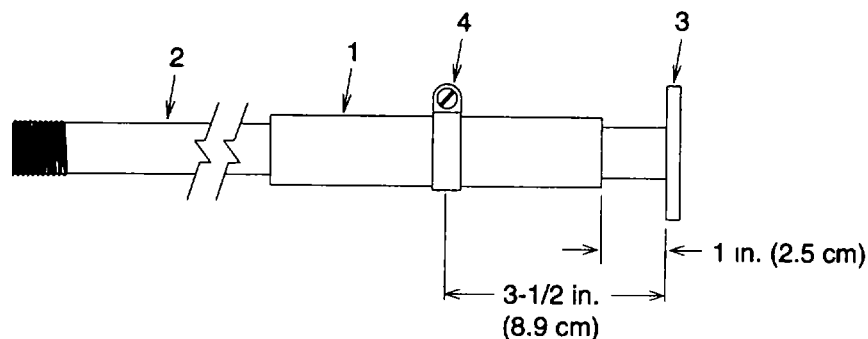

Figure 4-21. Gas Tube Assembly Dimensions

- (4) Wrap antisieze tape around threaded end of dip tube (34) (fig. 4-20) and connect to reducer (33).
- (5) Wrap antisieze tape around threaded ends of nipple (31) and male end of reducer (33). Connect reducer (33), elbow (32), nipple (31), and union (15) half.
- (6) Wrap antisieze tape around threaded ends of nipple (28). Connect reducer (30), elbow (29), nipple (28), and union (15) half.
- (7) Wrap antisieze tape around threaded ends of nipples (25), (23), and (27). Connect union (15) half, nipple (27), tee fitting (26), nipple (25), elbow (24), nipple (23), and union (15) half.
- (8) Wrap antisieze tape around threaded ends of nipples (22), (20), (18), and (17). Connect nipple (22), elbow (21), nipple (20), ball valve (19), nipple (18), tee fitting (11), nipple (17), and check valve (16) with flow arrow pointed toward nipple (17).
- (9) Connect two union (15) halves.
- (10) Wrap antisieze tape around one threaded end of hose assembly (12) and connect to ball valve (14). Connect loose hose assembly (12) end without antisieze tape to swivel fitting (13)
- (12) Wrap antisieze tape around one threaded end of hose assembly (9) and connect to tee fitting (11). Connect loose hose assembly (9) end without antisieze tape to swivel fitting (10).
- (13) Push new cable (8) end through a new cable sleeve (52) and then loop through hole in valve mounting bracket (6). Push cable end back into cable sleeve. Secure by crimping sleeve. Repeat for charge valve mounting bracket (7).

4-22. DRY CHEMICAL TANK REPLACEMENT AND REPAIR - continued

- (14) Push loose cable (8) end through another new cable sleeve (52). Push cable end back into cable sleeve to form a loop Just large enough to fit retaining clip (4) through. Secure by crimping sleeve. Repeat for second cable (8)
- (15) Slip one retaining clip (4) into each cable (8) loop.
- (16) Install ball valve mounting bracket (7) onto ball valve (9) with two screws (5).
- (17) Install ball valve mounting bracket (6) onto ball valve (14) with two screws (5)
- (18) Install one retaining clip (4) over ball valve (9) handle m open position and one retaining clip over ball valve (14) handle m closed position. Install one strip tie (3) between each retaining clip and valve mounting bracket (6) and (7).
- (19) Install fill cap (1) and hand tighten only.

e. Installation (See figure 4-19.)

- (1) Remove cap (8) and place tank lifting tool (9) onto tank (10) fill collar. Install cap.

WARNING

Tank can swing while suspended from a lifting device causing injury to personnel and/or damage to equipment.

CAUTION

Piping is exposed extending outside of tank and can be damaged when lifting.

- (2) Attach lifting device to tank lifting tool (9). Secure tank (10) from swinging and carefully lift. Lower tank onto unit while aligning mounting holes.
- (3) Remove cap (8) and tank lifting tool (9). Install cap and hand tighten only
- (4) Install four screws (6), flat washers (7), new lock washers (5), and nuts (4).
- (5) Attach rod (2) to valve (3). Install new spring pin (1) Place valve m closed position.
- (6) Install cylinders per paragraph 4-11.
- (7) Install discharge and charging hose per paragraph 4-15, b
- (8) Install lift bar per paragraph 4-21
- (9) Fill tank (8) with dry chemical per paragraph 2-10.

4-23 AFFT TANK HEATER ASSEMBLY REPLACEMENT AND REPAIR.

This task covers:

a. Disassembly

b. Repair

d. Replacement

INITIAL SETUP:**Tools**

General Mechanics Tool Kit, Appendix B, Section III, item 1

General Safety Instructions

Materials/Parts

Terminal Lug, Appendix H, item 7

Lock Washers (2), Appendix H, item 6

Spring Pin, Appendix H, item 5

Electrical Insulation Tape, Appendix E, Section II, item 5

Adhesive Sealant (Silicone), Appendix E, Section II, Item 6

Heat Sink Compound, Appendix E, Section II, item 7

WARNING

- Servicing the equipment with power connected can result in serious personal injury or DEATH.
- Servicing the equipment with the system pressurized can result in serious personal injury.
- Discharging nitrogen in an enclosed, unventilated space can cause suffocation.

- a. **Disassembly** (See figure 4-22.)

WARNING

Servicing the equipment with power connected can result in serious personal injury or DEATH.

- (1) Disconnect power plug (1) from power source.
- (2) Remove pin (2) and rod (3). Discard pin.
- (3) Remove insulation protectors (4) and insulation (5).
- (4) Tag and disconnect heating cable (6) leads from wire leads (7).
- (5) Remove heating cables (6) and any electrical insulation tape that may be left on pipes

WARNING

- **Servicing the equipment with the system pressurized can result in serious personal injury.**
- **Discharging nitrogen in an enclosed, unventilated space can cause suffocation**

- (6) Check that cylinder valves are closed and system pressure has been relieved. See paragraph 4-11 steps (1) and (2).
- (7) Remove fill cap (8).

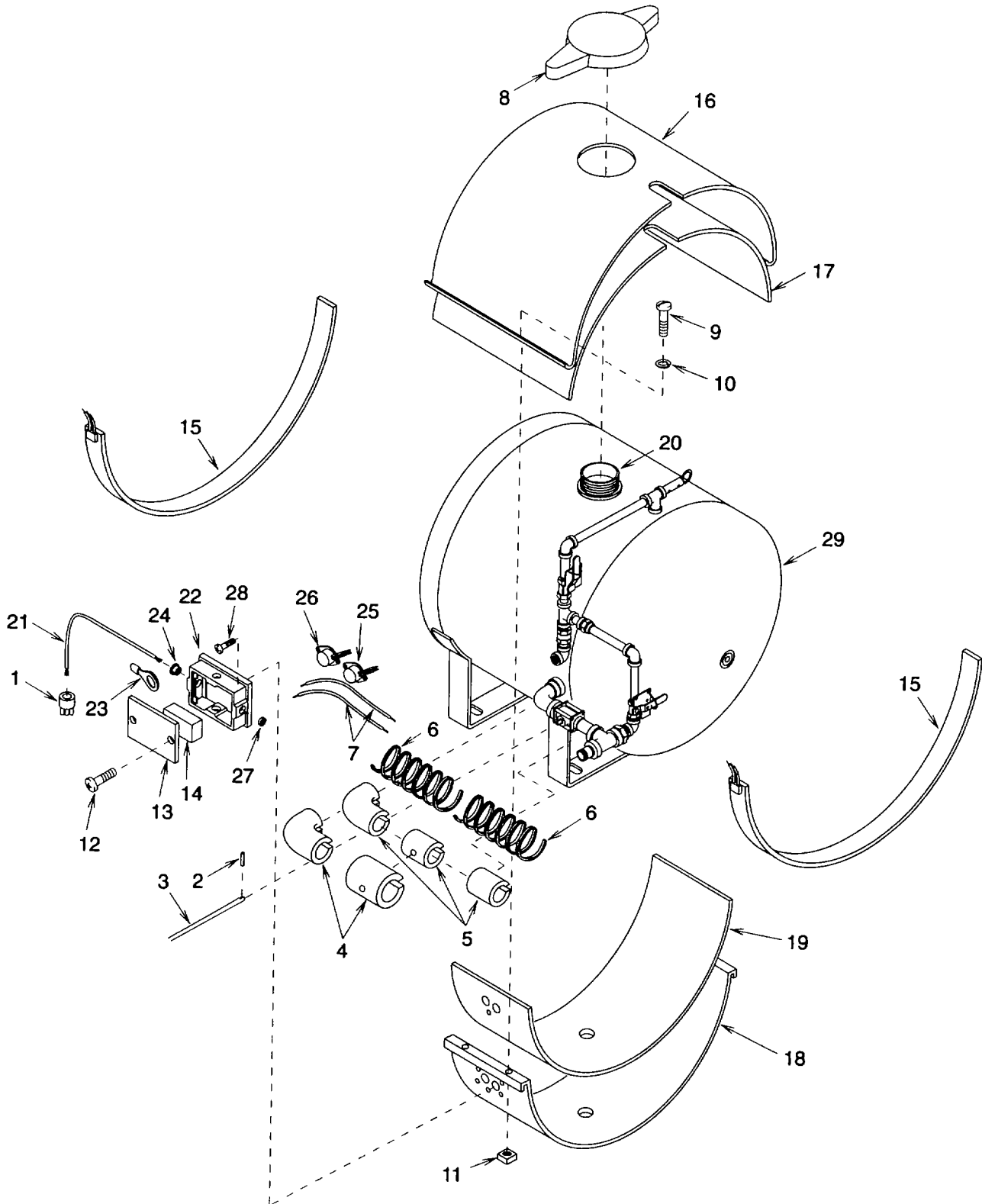

Figure 4-22. AFFF Tank Heater Assembly

- (8) Remove two screws (9), lock washers (10), and nuts (11). Discard lock washers.
- (9) Remove two screws (12), cover (13), and rubber pad (14).
- (10) Tag and disconnect heater blankets (15) leads.
- (11) Remove insulation wrapper (16) and blanket (17)
- (12) Remove insulation wrapper (18) and blanket (19).
- (13) Remove any remaining adhesive sealant from around fill collar (20) and insulation wrapper (16)
- (14) Tag and disconnect wire leads from power plug (1). Remove power cord (21) from power plug.
- (15) Tag and disconnect power cord (21) leads from inside enclosure (22). Remove and discard terminal lug (23).
- (16) Remove power cord (21) and strain relief (24)
- (17) Tag and disconnect wire leads (7) Remove wire leads.
- (18) Refer to wiring diagram figure 4-23 and schematic figure 4-24 to tag and disconnect temperature control thermostat (25) and temperature cutout thermostat (26) leads inside enclosure (22). Tag and remove thermostats
- (19) Remove knock out plug (27).
- (20) Remove four screws (28) and enclosure (22).
- (21) Remove heater blankets (15). If heater blankets are to be reused, protect adhesive backing from damage.
- (22) If necessary clean tank (29) area where heater blankets (15) were removed.

b. Repair

Repair is limited to replacement of defective or damaged components only.

c. Assembly (See figure 4-22)

- (1) If using new heater blankets (15), peel backing paper off to expose adhesive. Attach heater blankets to tank (29).
- (2) Install enclosure (22) and four screws (28).
- (3) Install knock out plug (27).
- (4) Install temperature control thermostat (25) and temperature cutout thermostat (26) position per tags and wiring diagram figure 4-23. Insert the wire leads through the insulation blanket (19) and wrapper (18) then slip the thermostat into the insulation blanket hole.
- (5) Install wire leads (7).
- (6) Install strain relief (24) and power cord (21). Connect new terminal lug (23) to ground wire inside enclosure (22). See wiring diagram figure 4-23.
- (7) Install power plug (1) onto power cord (21) and connect wire leads per tags and wiring diagram figure 4-23

4-23. AFFF TANK HEATER ASSEMBLY REPLACEMENT AND REPAIR.-continued

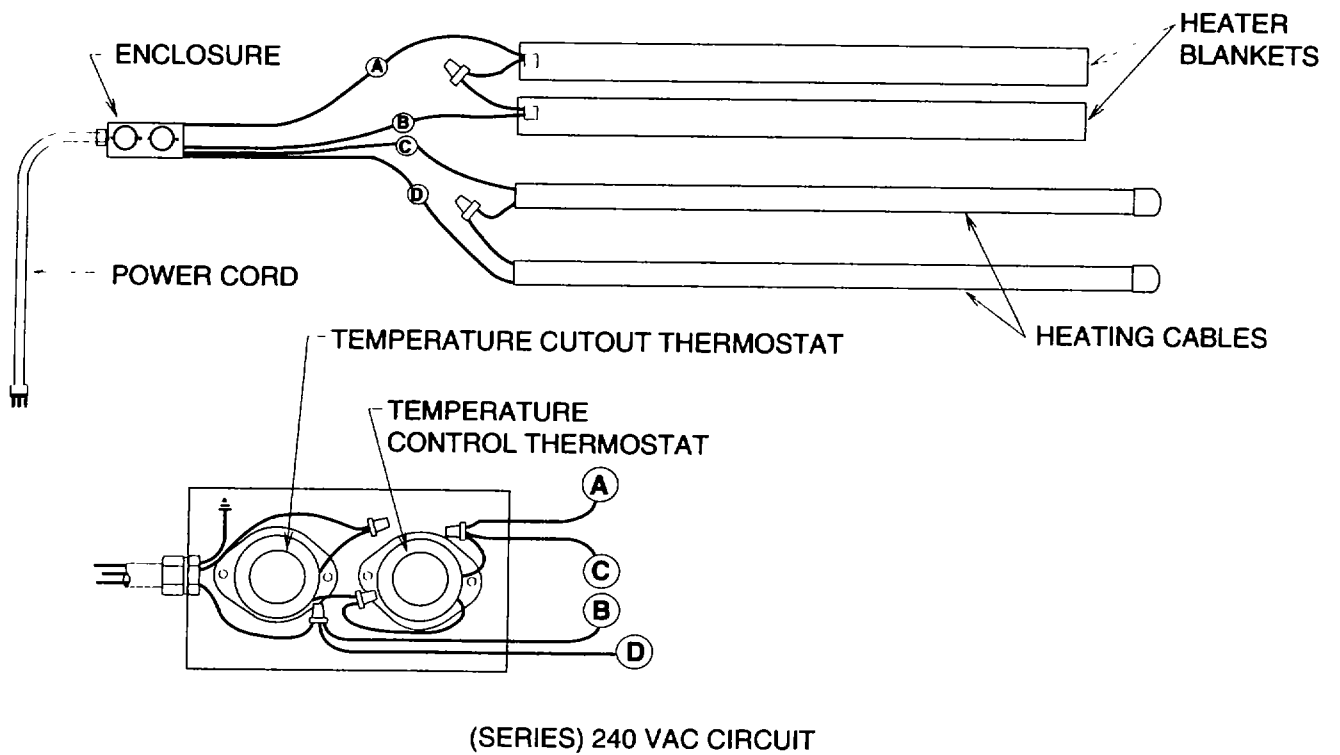
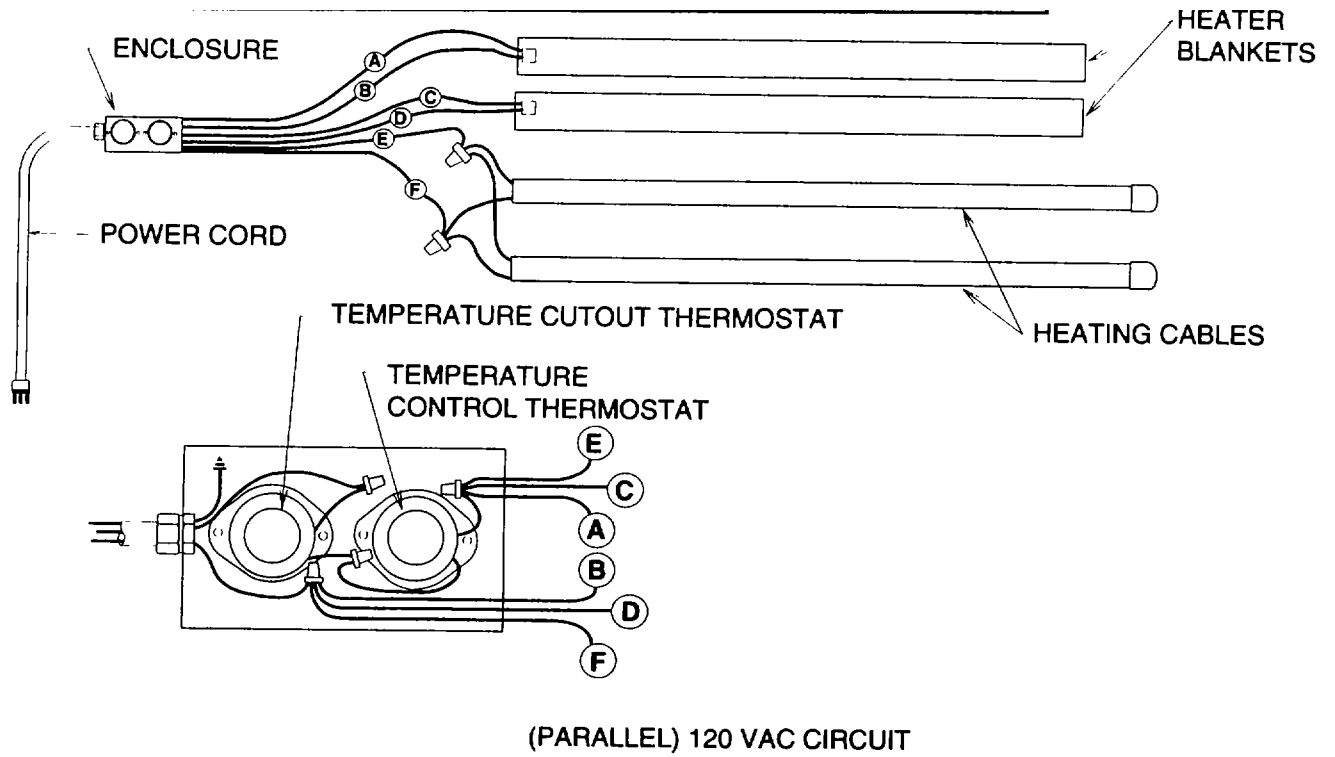
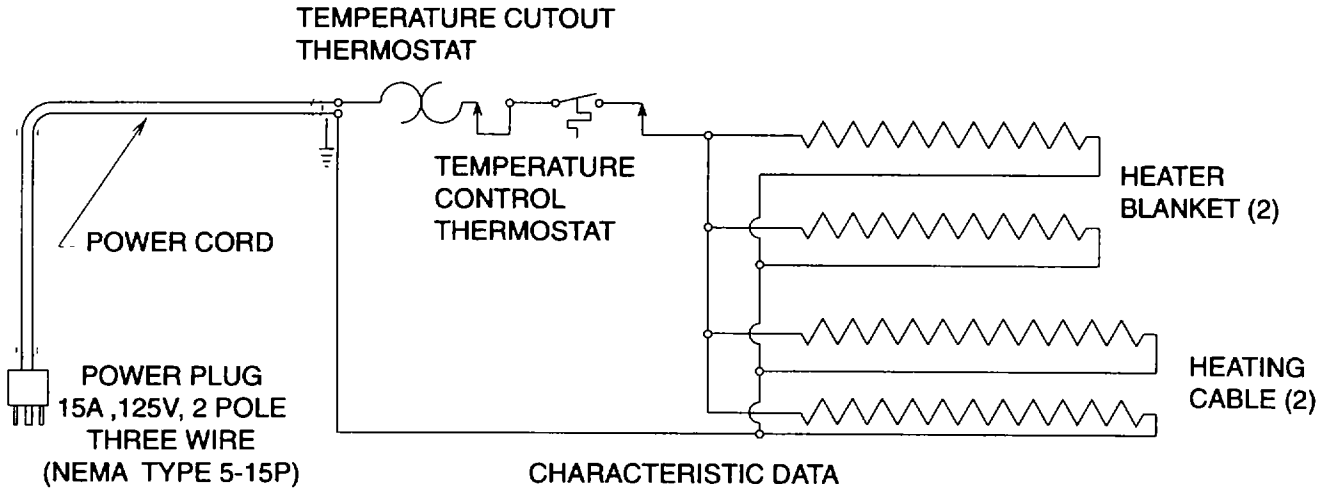

Figure 4-23. AFFF Tank Heater Wiring Diagram

120 VAC CIRCUIT



CHARACTERISTIC DATA
 POWER RATING - 1300 WATTS
 VOLATGE - 120 VOLTS AC
 AMPERAGE - 10.8 AMPS AC

240 VAC CIRCUIT

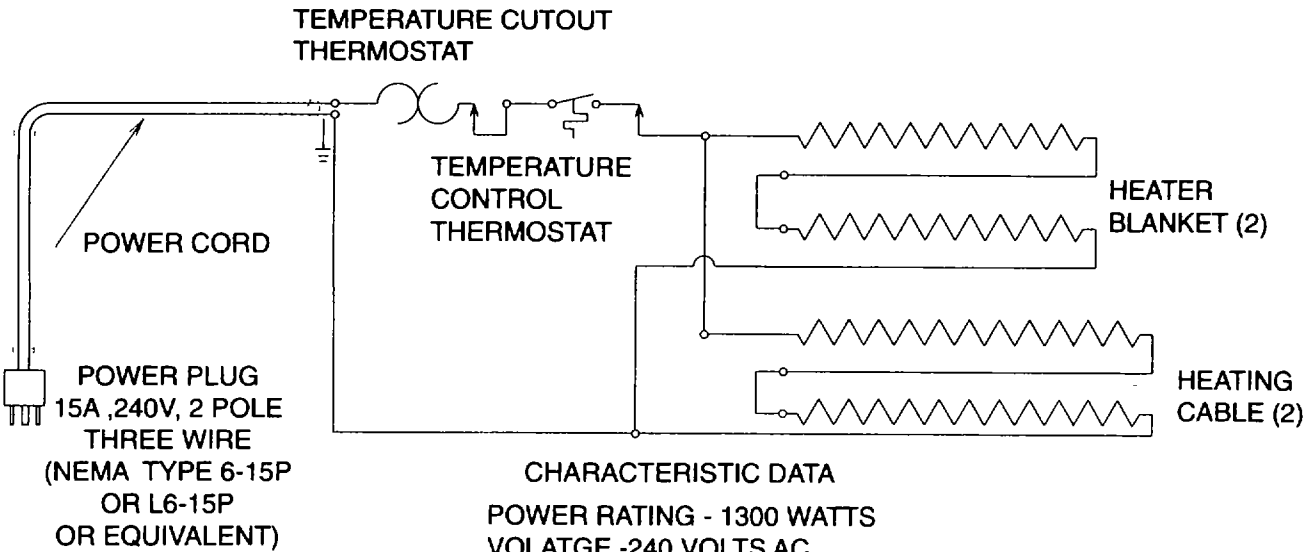

CHARACTERISTIC DATA
 POWER RATING - 1300 WATTS
 VOLATGE - 240 VOLTS AC
 AMPERAGE - 5.4 AMPS AC

Figure 4-24. AFFF Tank Heater Electrical Schematic

4-23. AFFF TANK HEATER ASSEMBLY REPLACEMENT AND REPAIR. - continued

- (8) Carefully install insulation blanket (19) and wrapper (18) Feed blanket heater (15) leads through hole in insulation blanket and wrapper

NOTE

Heaters can be wired for either 120 or 240 vac operation.

- (9) Carefully install insulation blanket (17) and wrapper (16).
- (10) Coat the tank (29) contacting surface of temperature control thermostat (25) and temperature cutout thermostat (26) with heat sink compound. Install two screws (9), new lock washers (10), and nuts (11)
- (11) Seal the insulation exposed around the fill collar (20) with adhesive sealant to prevent water from settling around fill collar and being absorbed into insulation blanket (17)
- (12) Connect wire leads inside enclosure (22), for voltage being used, per tags and wiring diagram figure 4-23 and schematic figure 4-24.
- (13) Install rubber pad (14), cover (13), and two screws (12).
- (14) Install fill cap (8)
- (15) Install heating cables (6). Secure to pipe with electrical tape
- (16) Connect heating cable (6) leads to wire leads (7) per tags and wiring diagram figure 4-23.
- (17) Install insulation (5) and insulation protectors (4)
- (18) Install rod (3) and new pin (2). Be sure rod is in closed position.
- (19) Install fill cap (8) and hand tighten only

4-24. AFFF TANK REPLACEMENT AND REPAIR.

This task covers:

a. Disassembly

b. Repair

d. Replacement

INITIAL SETUP:

Tools

General Mechanics Tool Kit, Appendix B, Section III, Item 1

Tank Lifting Tool, Appendix B, Section III, item 6

Lifting Device (Two Ton Capacity)

General Safety Instructions

Materials/Parts

Antisieze Tape, Appendix E, Section II, item 4

Strip Ties (2), Appendix H, item 32

Spring Pin, Appendix H, item 5

Equipment Condition:

Set parking brakes and lower jacks (para 4-29).

Remove discharge hose and charging hose (para 4-15 steps (1) and (3))

Remove AFFF tank heater assembly (para 4-23).

WARNING

Tank can swing while suspended from a lifting device causing injury to personnel and/or damage to equipment

a. Removal (See figure 4-25.)

- (1) Siphon all AFFF solution from tank (1).
- (2) Remove spring pin (2) and rod (3) from valve (4). Discard spring pin.
- (3) Remove four nuts (5), lock washers (6), screws (7), and flat washers (8). Discard lock washers
- (4) Place tank lifting tool (9) onto tank (1) fill collar. Install cap (10)

WARNING

Tank can swing while suspended from a lifting device causing injury to personnel and/or damage to equipment.

CAUTION

Piping is exposed extending outside of tank and can be damaged when lifting.

- (5) Attach lifting device to tank lifting tool (9). Secure tank (1) from swinging and carefully lift. Lower tank onto level ground or suitable work area floor.
- (6) Remove cap (10) and tank lifting tool (9)

4-24. AFFF TANK REPLACEMENT AND REPAIR. - continued

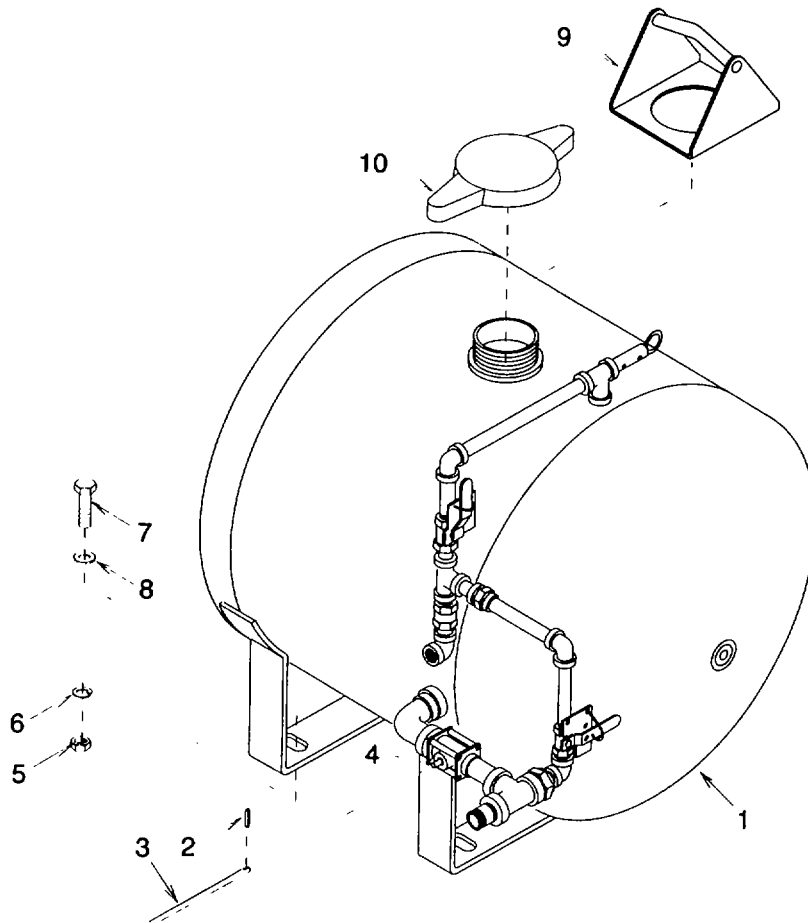

Figure 4-25. AFFF Tank Assembly Removal

b. Disassembly (See figure 4-26)

- (1) Break two strip ties (1) and pull two retaining clips (2).
- (2) Remove two screws (3) and valve mounting bracket (4).
- (3) Remove two screws (3) and valve mounting bracket (5).
- (4) Slip cable (6) off each retaining clip (2).
- (5) Cut cable (6) from valve mounting brackets (4) and (5). Discard cables.
- (6) Disconnect elbow (7), nipple (8), check valve (9), and nipple (10)
- (7) Separate union (11) halves
- (8) Disconnect union (11) half, nipple (12), tee fitting (13), nipple (14), ball valve (15), nipple (16), elbow (17), nipple (18), pressure relief valve (19), tee fitting (20), and nipple (21).

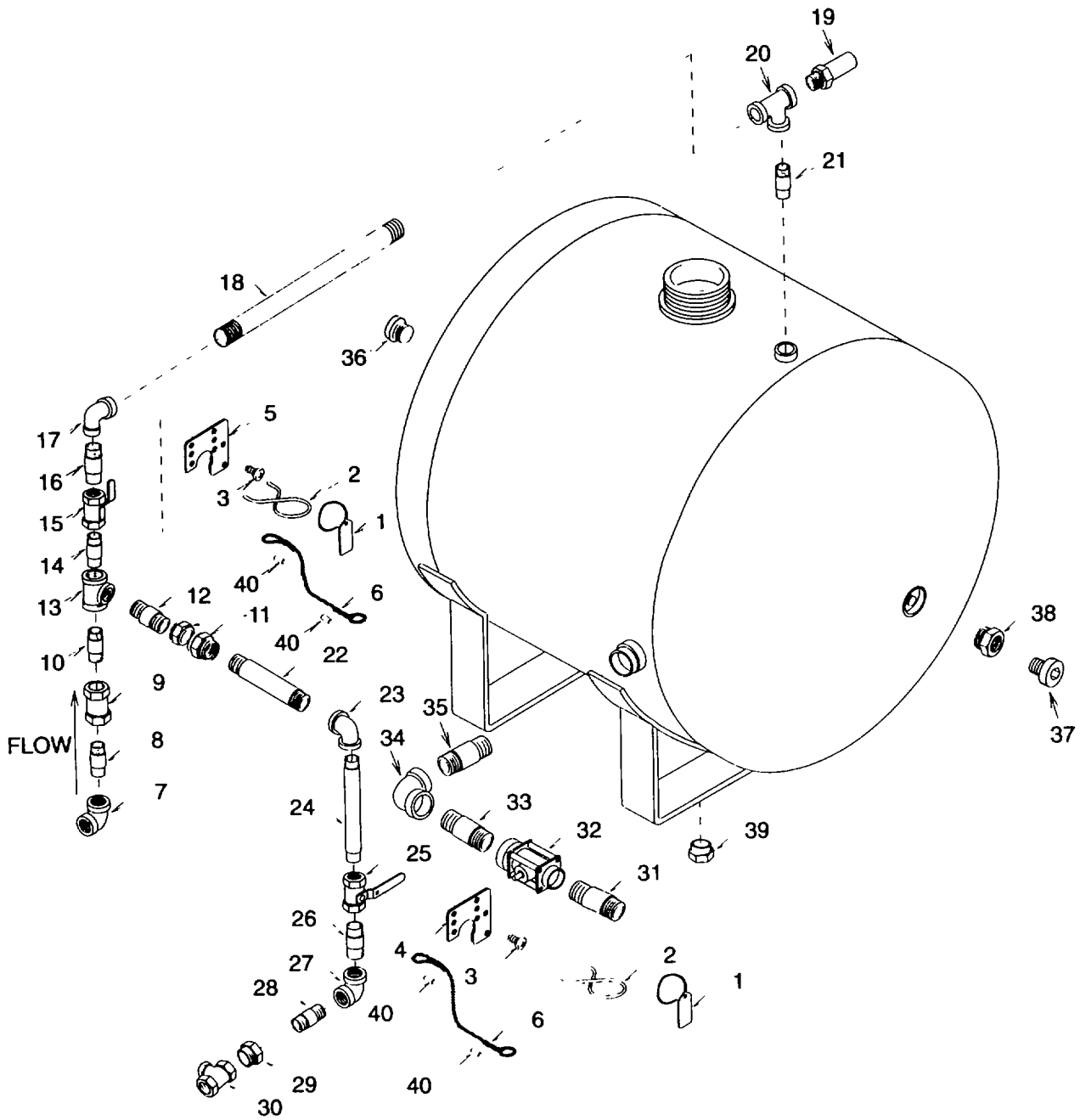

Figure 4-26. AFFF Tank Assembly

- (9) Disconnect union (11) half, nipple (22), elbow (23), nipple (24), ball valve (25), nipple (26), elbow (27) nipple (28), reducer (29), tee fitting (30), nipple (3 1), ball valve (32), nipple (33), elbow (34), and nipple (35)
- (10) Disconnect plug (36)

4-24. AFFF TANK REPLACEMENT AND REPAIR. - continued

- (11) Disconnect plug (37) and reducer (38)
- (12) Disconnect plug (39).

c. Repair

Repair is by replacement of defective or damaged components only.

d. Assembly (See figure 4-26)

- (1) Wrap antisieze tape around threaded end of plug (39). Connect plug.
- (2) Wrap antisieze tape around threaded end of plug (37) and male end of reducer (38) Connect Reducer (38) and plug (37)
- (3) Wrap antisieze tape around threaded end of plug (36) Connect plug
- (4) Wrap antisieze tape around threaded ends of nipples (35), (33), (31), (28), (26), (24), (22) and male end of reducer (29) Connect nipple (35), elbow (34), nipple (33), ball valve (32), nipple (31), tee fitting (30), reducer (29), nipple (28), elbow (27), nipple (26), ball valve (25), nipple (24), elbow (23), nipple (22), and union (11) half.
- (5) Wrap antisieze tape around threaded ends of nipples (21), (18), (16), (14), (12) and male end of pressure relief valve (19). Connect nipple (21), tee fitting (20), pressure relief valve (19), nipple (18), elbow (17), nipple (16), ball valve (15), nipple (14), tee fitting (13), nipple (12), and union (11) half.
- (6) Connection (11) halves.
- (7) Wrap antisieze tape around threaded ends of nipples (10) and (8). Connect nipple (10), check valve (9) with flow arrow pointed toward nipple (10), nipple (8), and elbow (7)
- (8) Push new cable (6) end through a new cable sleeve (40) and then loop through hole in valve mounting bracket (4) Push cable end back into cable sleeve. Secure by crimping sleeve Repeat for valve mounting bracket (5).
- (9) Push loose cable (6) end through another new cable sleeve (40) Push cable end back into cable sleeve to form a loop Just large enough to fit retaining clip (2) through. Secure by crimping sleeve Repeat for second cable (6)
- (10) Slip one retaining clip (2) into each cable (6) loop.
- (11) Install valve mounting bracket (5) onto ball valve (15) with two screws (3).
- (12) Install valve mounting bracket (4) onto ball valve (25) with two screws (3)
- (13) Install one retaining clip (2) over charge ball valve (15) handle in open position and one retaining clip over ball valve (25) handle In closed position. Install one strip tie (1) between each retaining clip and valve mounting bracket (4) and (5).

e. Installation (See figure 4-25.)

- (1) Place tank lifting tool (9) onto tank (1) fill collar. Install cap (10).

WARNING

Tank can swing while suspended from a lifting device causing injury to personnel and/or damage to equipment

CAUTION

Piping is exposed extending outside of tank and can be damaged when lifting.

- (2) Attach lifting device to tank lifting tool (9). Secure tank (1) from swinging and carefully lift. Lower tank onto unit while aligning mounting holes.
- (3) Remove cap (10) and tank lifting tool (9).
- (4) Install rod (3) and new spring pin (2).
- (5) Install four flat washers (8), screws (7), new lock washers (6), and nuts (5).
- (6) Install discharge hose and charging hose per paragraph 4-18, (4) and (8).
- (7) Install AFFF tank heater assembly per paragraph 4-23.
- (8) Fill tank (1) with AFFF solution per paragraph 2-10.
- (9) Release parking brakes and raise jacks, per paragraph 4-29, if moving equipment.

4-25. SKID FRAME REPAIR

This task covers:

a. Disassembly

b. Repair

d. Replacement

INITIAL SETUP:

Tools

General Mechanics Tool Kit, Appendix B, Section HI, Item 1

Materials/Parts

Lock Washers (10), Appendix H, item 8

Lock Washers (16), Appendix H, item 9

Safety Solvent Cleaner, Appendix E, Section II, item 1

Rags, Appendix E, Section II, item 2

Adhesive, Appendix E, Section II, item 3

Equipment Condition:

Remove cylinders (para 4-11).

Remove rods (para 4-22 and 4-24).

General Safety Instructions

WARNING

⚠ Keep safety solvent cleaner away from sparks or flame. The solvent cleaner is flammable and the vapors can be explosive.

⚠ Use safety solvent cleaner in a well ventilated area. Wear gloves and eye protection when using solvent cleaner. Repeated or prolonged skin contact or inhalation of solvent cleaner vapors can be toxic.

a. Disassembly (See figure 4-27.)

(1) Remove two bushings (1).

(2) Remove 16 nuts (2), lock washers (3), flat washers (4), screws (5), and slide buttons (6). Discard lock washers.

(3) Remove two sets of pads (7).

WARNING

- **Keep safety solvent cleaner away from sparks or flame. The solvent cleaner is flammable and the vapors can be explosive.**
- **Use safety solvent cleaner in a well ventilated area. Wear gloves and eye protection when using solvent cleaner. Repeated or prolonged skin contact or inhalation of solvent cleaner vapors can be toxic.**

(4) Remove any adhesive remaining on frame (8) surface using safety solvent cleaner and a stiff brush or rag.

(5) Be sure frame (8) surface is clean and free of any dirt or oils.

b. Repair

Repair is limited to replacement of defective or damaged components only.

c. Assembly

- (1) Coat mating surfaces of frame (8) and pad (7) with adhesive. Let both surfaces air dry until adhesive is tacky but will not stick to fingers.
- (2) Carefully attach pad (7) to frame (8). Press into firm contact all over.
- (3) Install 16 slide buttons (6), screws (5), flat washers (4), new lock washers (3), and nuts (2).
- (4) Install two bushings (1).
- (5) Install cylinders per paragraph 4-11.
- (6) Install rods per paragraphs 4-22 and 4-24.

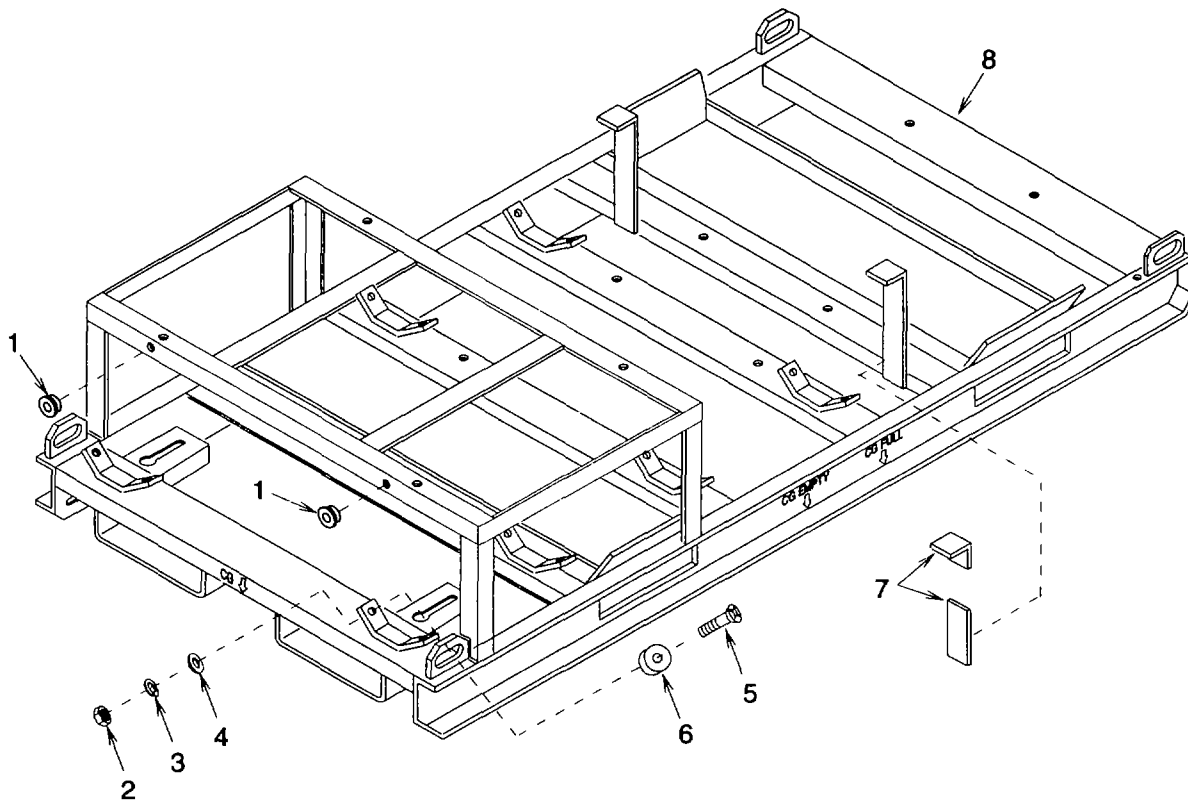

Figure 4-27. Skid Frame Repair Items

4-26. JACK STAND (REAR) REPLACEMENT.

This task covers:

a. Removal**b. installation****INITIAL SETUP:**Tools

Jack (Two Ton Capacity), Appendix B, Section III, item 2

Jack Stands (2) (Two Ton Capacity), Appendix B, Section III, item 2

Equipment Condition:

Set Parking Brakes (para 4-29).

General Safety Instructions**WARNING****Performing maintenance on equipment that is not properly supported can result in equipment falling or being dropped causing personal injury.**a. Removal (See figure 4-28.)**WARNING****Performing maintenance on equipment that is not properly supported can result in equipment falling or being dropped causing personal injury.**

- (1) Lift rear of trailer (1) using jack and support with jack stands.
- (2) Remove handle (2).
- (3) Remove jack stand (3).

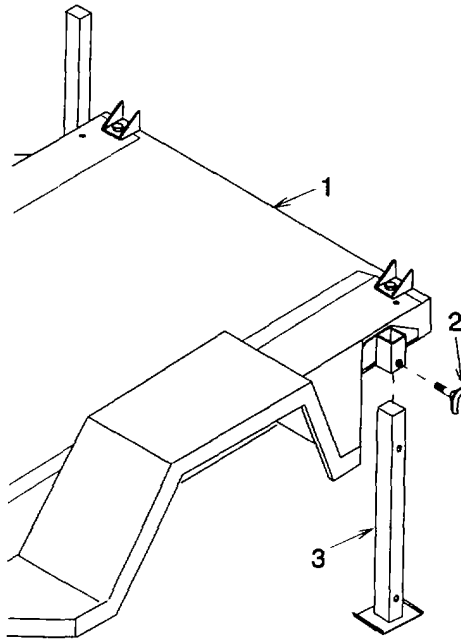
**Figure 4-28. Jack Stand, Rear**

b. Installation

- (1) Install jack stand (3) with holes facing side of trailer (1).
- (2) Install handle (2) into frame (1) and through either jack stand (3) hole as appropriate.
- (3) Remove jack stands using jack to lift then lower rear of trailer (1).

4-27. JACK STAND (FRONT) REPLACEMENT.

This task covers:

a. Removal

b. installation

INITIAL SETUP:

Tools

Jack (Two Capacity), Appendix B, Section III, Item 2
 Jack Stands (2) (Two Ton Capacity), Appendix B,
 Section III, item 2

Equipment Condition:

Set Parking Brakes (para 4-29).

General Safety Instructions

WARNING

Performing maintenance on equipment that is not properly supported can result in equipment falling or being dropped causing personal injury.

a. Removal (See figure 4-29.)

WARNING

Performing maintenance on equipment that is not properly supported can result in equipment falling or being dropped causing personal injury.

- (1) Lift front of trailer (1) using jack and support with jack stands.
- (2) Remove clip (2) and pin (3).
- (3) Remove jack (4).

4-27. JACK (FRONT) REPLACEMENT. - continued

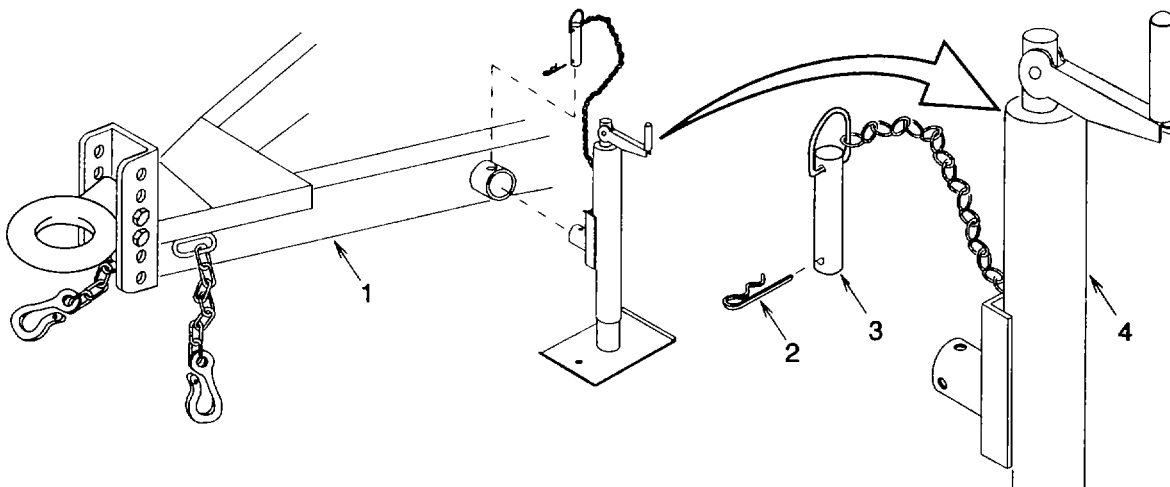

Figure 4-29. Jack

b. Installation

- (1) Install jack (4) in appropriate position.
- (2) Install pin (3) into frame (1) and through jack (4) hole.
- (3) Remove jack stands using jack to lift then lower rear of trailer (1)

4-28. TIRES/WHEELS REPAIR AND REPLACEMENT.

This task covers:

- | | | |
|--------------------|------------------------|------------------|
| a. Removal | b. Disassembly | c. Repair |
| d. Assembly | e. installation | |
-

INITIAL SETUP:ToolsGeneral Safety Instructions

General Mechanics Tool Kit, Appendix B, Section III
item 1

WARNING

Bead Breaker, Appendix B, Section III, item 2

Performing maintenance on equipment that is not properly supported can result in equipment falling or being dropped causing personal injury.

Jack (Two Ton Capacity), Appendix B, Section III,
item 2

Jack Stands (2) (Two Ton Capacity), Appendix B,
Section III, item 2

- a. Removal (See figure 4-30.)

WARNING

Performing maintenance on equipment that is not properly supported can result in equipment falling or being dropped causing personal injury.

- (1) Using jack, raise trailer mounted extinguisher just enough to remove tires/wheels. Support trailer frame when lifted with jack stands.
- (2) Remove 8 nuts (1) and wheel (2).
- (3) Depress valve (3) stem to release air pressure in tire (4).

- b. Disassembly

- (1) Separate tire (4) from wheel (2) using bead breaker.
- (2) Remove valve (3).

- c. Repair

Repair is limited to replacement of defective or damaged components only.

- d. Assembly

- (1) Install valve (3) into wheel (2). Pull through from inside until fully seated in wheel
- (2) Install tire (4) onto wheel (2).
- (3) Inflate tire (4) to between 75 and 80 psig (518 and 552 kPa).

4-28 TIRES/WHEELS REPAIR AND REPLACEMENT. - continued

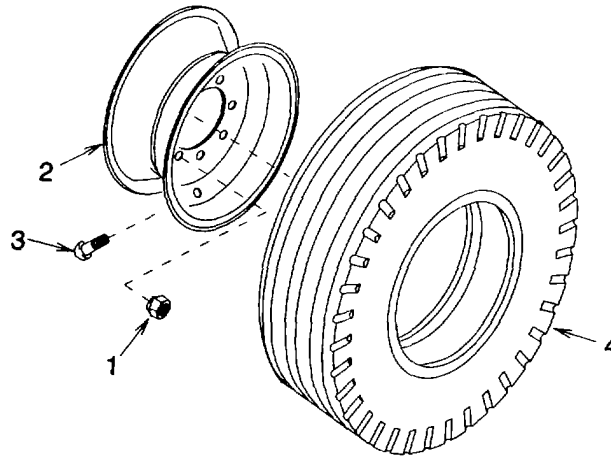

Figure 4-30. Tires/Wheels

e. Installation

- (1) Install wheel (2) and 8 nuts (1).
- (2) Remove jack stands using jack to lift then lower trailer mounted extinguisher.

4-29. PARKING BRAKES ADJUSTMENT REPAIR AND REPLACEMENT.

This task covers:

- | | | |
|---------------|-----------|-----------------|
| a. Removal | b. Repair | c. installation |
| d. Adjustment | | |

INITIAL SETUP:

Tools

General Mechanics Tool Kit, Appendix B, Section III, item 1

Materials/Parts

Cotter Pins (2), Appendix H, item 25

Cotter Pin, Appendix H, item 30

Equipment Condition

Remove tire/wheel (para 4-28).

Lock Washers (10), Appendix H, item 26

Self Locking Nuts (5), Appendix H, item 23

Self Locking Nuts (2), Appendix H, item 27

Grease, Appendix E, Section II, item 11

a. Removal (See figure 4-31.)

- (1) Release parking brake (1) lever (up/vertical) if set.

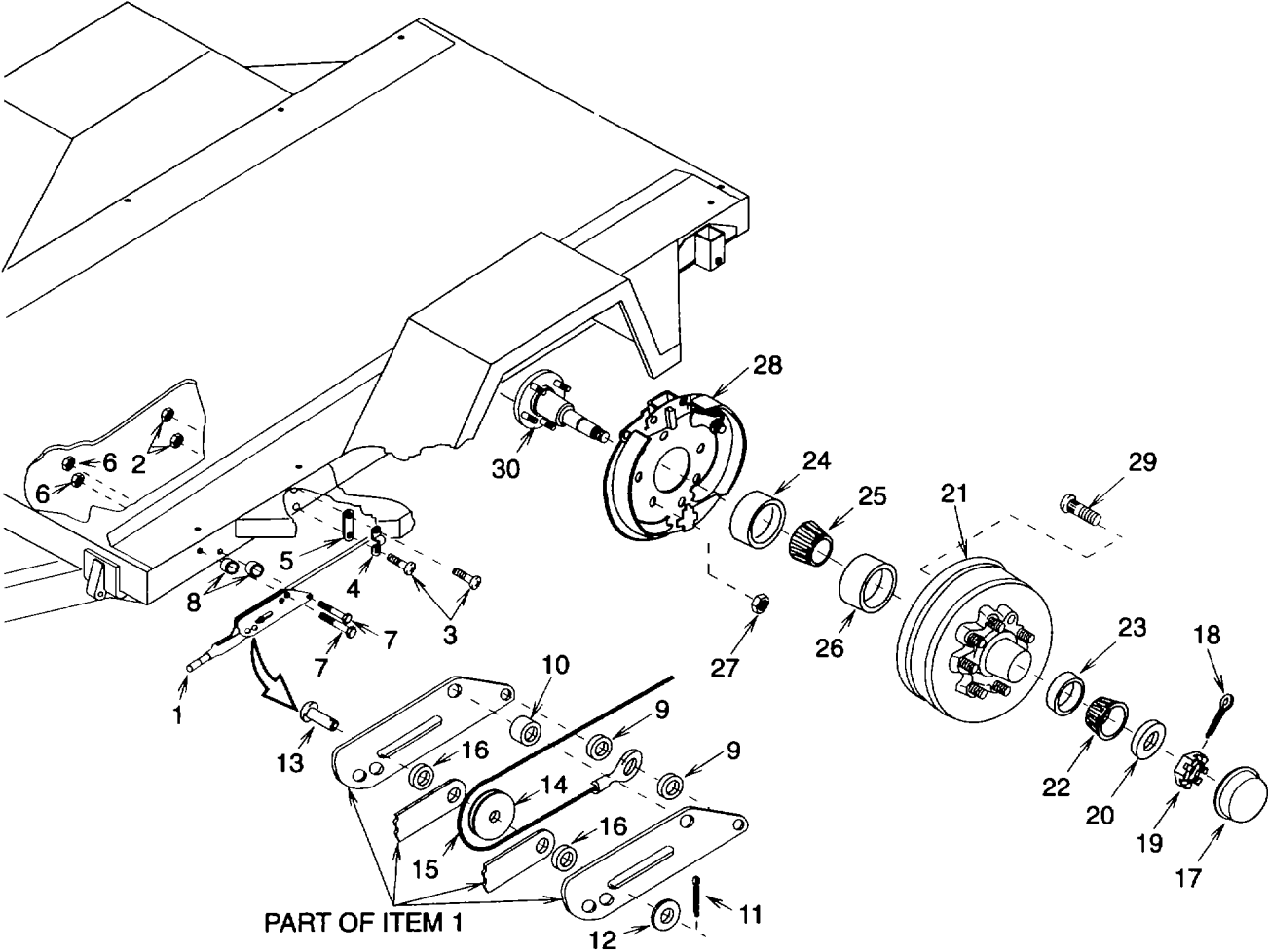

Figure 4-31. Parking Brakes

4-29 PARKING BRAKES ADJUSTMENT REPAIR AND REPLACEMENT - continued

- (2) Remove two lock nuts (2), screws (3), one clamp (4), and link (5). Discard lock nuts.
- (3) Remove two nuts (6), screws (2), spacers (8), spacers (9), one spacer (10), and parking brake lever (1).
- (4) Remove cotter pin (11), flat washer (12), shaft (13), roller (14), cable (15), and two spacers (16). Discard cotter pin.
- (5) Remove grease cap (17).
- (6) Remove cotter pin (18) and discard.
- (7) Remove spindle nut (19) and spindle washer (20).
- (8) Remove brake drum (21), outer bearing (22), and cup (23).
- (9) Remove grease seal (24), inner bearing (25), and cup (26).
- (10) Remove five lock nuts (27) and brake (28) assembly.

b. Repair (See figure 4-31.)

NOTE

- **Repair is limited to replacement of defective or damaged components only.**
- **The brake and cable is supplied as a complete assembly. If any one component is damaged or missing, except for lugs, the entire assembly must be replaced.**
- **The parking brake lever is supplied as a complete assembly. If any one component is damaged or missing, except for cotter pin, the entire assembly must be replaced.**

- (1) Replace any damaged lugs (29) if brake (21) is to be reused.
- (2) Replace axle per paragraph 4-30 if spindle (30) is damaged.

c. Installation

- (1) Install brake (28) assembly and five lock nuts (27).
- (2) Lubricate spindle (30) and inner bearing (25) with grease then install cup (26), inner bearing, and grease seal (2)
- (3) Lubricate outer bearing (22) with grease then carefully install brake drum (21), cup (23), and outer bearing.
- (4) Install spindle washer (20) and spindle nut (19). Tighten spindle nut until the brake drum (21) just begins to drag when turned. Loosen the spindle nut just until a slot aligns with hole in spindle (30).
- (5) Install new cotter pin (18).
- (6) Install grease cap (17).
- (7) Install two spacers (16), cable (15), roller (14), shaft (13), flat washer (12), and new cotter pin (11).
- (8) Install parking brake lever (1), spacer (10), two screws (2), spacers (9), cable (15), spacers (8), and nuts (6).

(9) Install link (5), cable (15), clamp (4), two screws (3), and new lock nuts (2).

(10) Install tires/wheels (para 4-28).

d. Adjustment (See figure 4-32.)

NOTE

Brakes are properly adjusted when set on (down/horizontal), the tires will skid on dry pavement when equipment is towed in either direction. If brakes cannot be adjusted to this point, they must be replaced.

(1) Secure unit from moving and release parking brakes (1) (up/vertical).

(2) Remove set screw (2).

(3) Adjust brakes by turning knob (3) clockwise to tighten or counterclockwise to loosen.

(4) Check brakes as noted and adjust if necessary.

(5) Secure knob (3) from turning using set screw (2) and set brakes (1) on (down/horizontal).

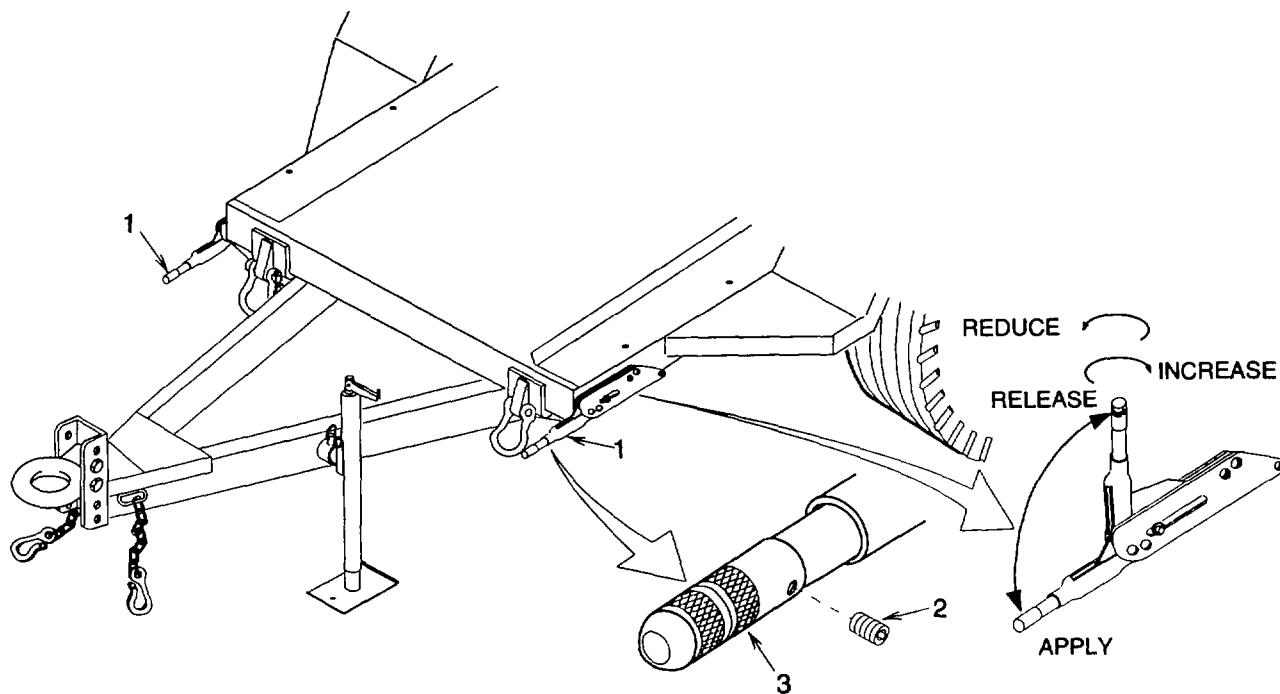

Figure 4-32. Parking Brake Adjustment

4-30. EXTINGUISHER TRAILER ASSEMBLY REPAIR AND REPLACEMENT.

This task covers:

a. Disassembly**b. Repair****c. Assembly****INITIAL SETUP:**Tools

General Mechanics Tool Kit, Appendix B, Section III, item 1

Jack (Two Ton Capacity), Appendix B, Section III, item 2

Jack Stands (2) (Two Ton Capacity), Appendix B, Section III, item 2

Lifting Device (Two Ton Capacity)

Materials/Parts

Self Locking Nuts (2), Appendix H, Item 24

Self Locking Nuts (12), Appendix H, items 33

Self Locking Nuts (8), Appendix H, item 31

Self Locking Nuts, (10), Appendix H, Items 34

General Safety Instructions**WARNING**

- Performing maintenance on equipment that is not properly supported can result in equipment falling or being dropped causing personal injury.
- Unit can swing while suspended from a lifting device causing injury to personnel and/or damage to equipment

Equipment Condition

Set parking brakes and lower jacks (para 4-29).

- a. Disassembly (See figure 4-33.)

NOTE**Disassemble only items necessary for repair or replacement.**

- (1) Stop block removal.

Remove nut (1), washer (2), screw (3), and rear stop block (4).

- (2) Pintle removal.

NOTE**Note which mounting holes pintle is secured to for installation. Remove two self locking nuts (5), screws (6), and pintle (7). Discard self locking nuts.**

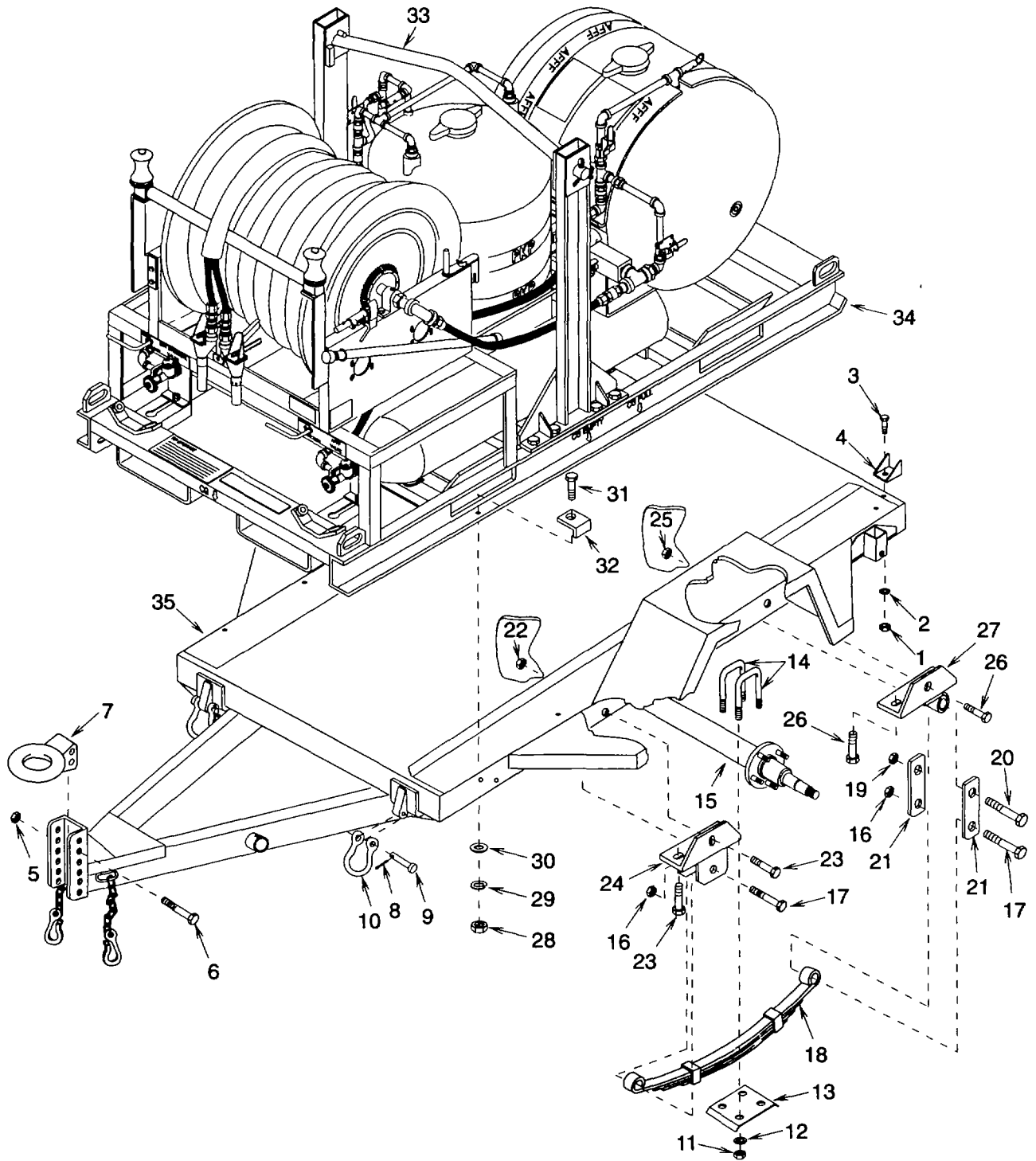

Figure 4-33. Trailer

4-30 EXTINGUISHER TRAILER ASSEMBLY REPAIR AND REPLACEMENT - continued

- (3) Tie down eye removal.

NOTE

The lifting and hold down eye is supplied as a complete assembly. If any one component is damaged, the entire assembly must be replaced. Do not remove unless replacement is necessary. Remove cotter pin (8), pin (9), and eye (10).

- (4) Axle and spring removal

WARNING

Performing maintenance on equipment that is not properly supported can result in equipment falling or being dropped causing personal injury.

- (a) Using jack and four jack stands, raise and secure unit.
- (b) Remove wheels/tires per paragraph 4-28.
- (c) Remove brakes per paragraph 4-29.
- (d) Remove eight nuts (11), lock washers (12), two plates (13), four u-bolts (14), and axle (15). Discard lock washers.
- (e) Remove four lock nuts (16), screws (17), and two springs (18). Discard lock nuts.
- (f) Remove two lock nuts (19), screws (20), and two shackles (21). Discard lock nuts.
- (g) Remove six lock nuts (22), screws (23), and two front spring holders (24). Discard lock nuts.

NOTE

Rear spring holders are different for left and right side. Note difference before removing.

- (h) Remove six lock nuts (25), screws (26), and two rear spring holders (27). Discard lock nuts.

- (5) Frame removal

- (a) Remove 10 nuts (28), lock washers (29), flat washers (30), screws (31), and hold down clamps (32).

WARNING

Unit can swing while suspended from a lifting device causing injury to personnel and/or damage to equipment.

- (b) Attach lifting device to lifting bar (33) and remove skid assembly (34) from frame (35)

WARNING

Performing maintenance on equipment that is not properly supported can result in equipment falling or being dropped causing personal injury.

- (c) Using jack and four jack stands, raise and secure frame (35).
- (d) Remove six lock nuts (22) and screws (23). Discard lock nuts.
- (e) Remove six lock nuts (25) and screws (26). Discard lock nuts.
- (f) Remove two stop blocks (4), one pintle (7), and four tie down eyes (10) per steps (1) through (3) above.
- (g) Remove front jack per paragraph 4-27.
- (h) Remove rear jack stands per paragraph 4-26.
- (i) Remove frame (35).

b. Repair (See figure 4-33.)

- (1) Repair is limited to replacement of defective or damaged components only.
- (2) Send frame (35) to Direct Support Maintenance for repair.

c. Assembly (See figure 4-33.)

(1) Stop block installation.

Install rear stop block (4), screw (3), washer (2), and nut (1).

(2) Pintel installation.

Install pintle (7), aligned with mounting holes noted during disassembly, two screws (6) and new self locking nuts (5).

(3) Tie down eye installation.

Install eye (10), pin (9), and cotter pin (8).

(4) Axle and springs installation.

NOTE

Rear spring holders are different for left and right side. Be sure to install on proper side as noted during removal.

- (a) Install two rear spring holders (27) and secure using six screws (26) and new lock nuts (25).
- (b) Install two front spring holders (24) and secure using six screws (23) and new lock nuts (22).
- (c) Install four shackles (21) and secure using two screws (20) and new lock nuts (19).
- (d) Install two springs (18) and secure using four screws (17) and new lock nuts (16).

4-30 EXTINGUISHER TRAILER ASSEMBLY REPAIR AND REPLACEMENT. - continued I

- (e) Install axle (15) and center on springs (18). Be sure axle is centered between frame (35) wheel wells. Secure using four u-bolts (14), two plates (13), and eight new lock washers (12) and nuts (11)
- (f) Install brakes per paragraph 4-29
- (g) Install wheels/tires per paragraph 4-28.
- (h) Using jack, remove four jack stands and lower unit

(5) Frame installation.

WARNING

Performing maintenance on equipment that is not properly supported can result in equipment falling or being dropped causing personal injury.

- (a) Position frame (35) onto four jack stands over axle (15) assembly.
- (b) Align each rear spring holder (27) mounting holes to frame (35) and install six screws (26) and new lock nuts (25)
- (c) Align each front spring holder (24) mounting holes to frame (35) and install six screws (23) and new lock nuts (22)
- (d) Install two stop blocks (4), one pintle (7), and four tie down eyes (10) per steps (1) through (3) above.

WARNING

Unit can swing while suspended from a lifting device causing injury to personnel and/or damage to equipment.

- (e) Attach lifting device to lifting bar (33) and position skid assembly (34) onto frame (35)
- (f) Install 10 hold down clamps (32), screws (31), flat washers (30), new lock washers (29), and nuts (28)
- (g) Install front jack per paragraph 4-27
- (h) Install rear jack stands per paragraph 4-26.
- (i) Using jack, remove four jack stands and lower unit.

4-31. HOSES REPLACEMENT.

This task covers:

a. Removal

b. installation

INITIAL SETUP:ToolsMaterials/Parts

General Mechanics Tool Kit, Appendix B, Section III,
item 1

Antisieze Tape, Appendix E, Section II, item 4

a. Removal (See figure 4-34.)

- (1) Release quick coupling half (1) and disconnect hoses (2) and (3).
- (2) Disconnect reducing coupling (4) from hose reel swivel elbow.
- (3) Disconnect reducing coupling (4) and quick coupling half (5) from dry chemical hose assembly (2). Replace reducing coupling or quick coupling half if damaged.
- (4) Disconnect reducing coupling (6) from hose reel swivel elbow.
- (5) Disconnect reducing coupling (6) and quick coupling half (1) from AFFF hose assembly (3). Replace reducing coupling or quick coupling half if damaged.

b. Installation (See figure 4-34.)

- (1) Wrap antisieze tape onto threaded fittings of dry chemical hose assembly (2).
- (2) Connect reducing coupling (4) and quick coupling half (5) to dry chemical hose assembly (2) and tighten.
- (3) Wrap antisieze tape onto threaded fitting of hose reel swivel elbow.
- (4) Connect reducing coupling (4) to hose reel swivel elbow and tighten.
- (5) Wrap antisieze tape onto threaded fittings of AFFF hose assembly (3).
- (6) Connect reducing coupling (6) and quick coupling half (1) to dry chemical hose assembly (3) and tighten.
- (7) Wrap antisieze tape onto threaded fitting of hose reel swivel elbow.
- (8) Connect reducing coupling (6) to hose reel swivel elbow and tighten.
- (9) Release quick couplings half (1) and connect hoses (2) and (3) together.

4-31 HOSES REPLACEMENT. - continued

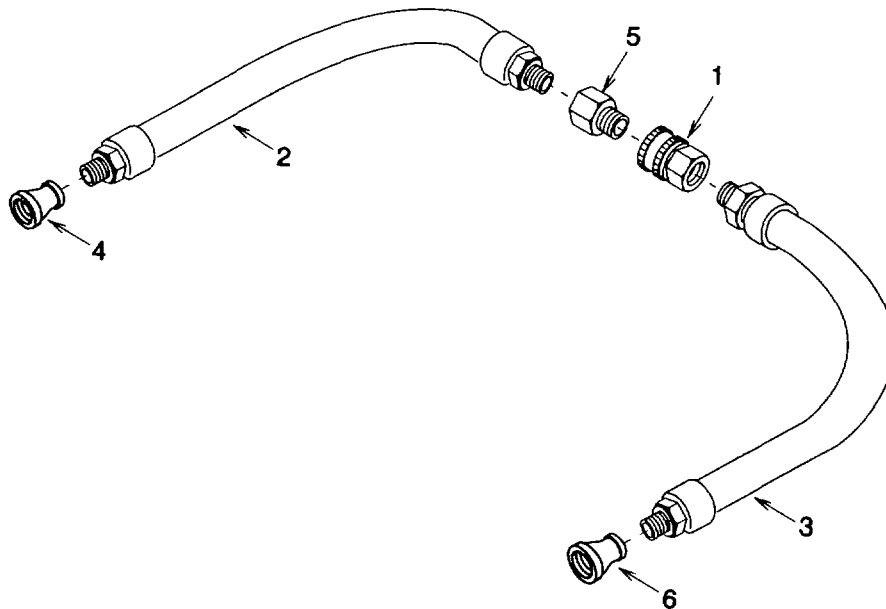

Figure 4-34. Hoses

4-32. REMOTE AUXILIARY HOSE REEL CART REPAIR AND REPLACEMENT.

This task covers:

a. Disassembly

b. Repair

c. Assembly

INITIAL SETUP:Tools

General Mechanics Tool Kit, Appendix B, Section III,
item 1

Materials/Parts

Cotter Pins (2), Appendix H, item 10

a. Disassembly**NOTE**

Repair is limited to replacement of damaged components.

(1) Remove two dust caps (1), cotter pins (2), flat washers (3), wheels and tires (4), and spacers (5) from cart (6) axles. Discard cotter pins.

(2) Remove hose reel assembly per paragraph 4-19.

b. Repair

Repair is limited to replacement of defective or damaged components only.

c. Assembly

- (1) Install spacers (5), wheels and tires (4), and flat washers (3) onto cart (6) axles. Secure with new cotter pins (2) and install dust caps (1).
- (2) Install hose reel assembly per paragraph 4-19.

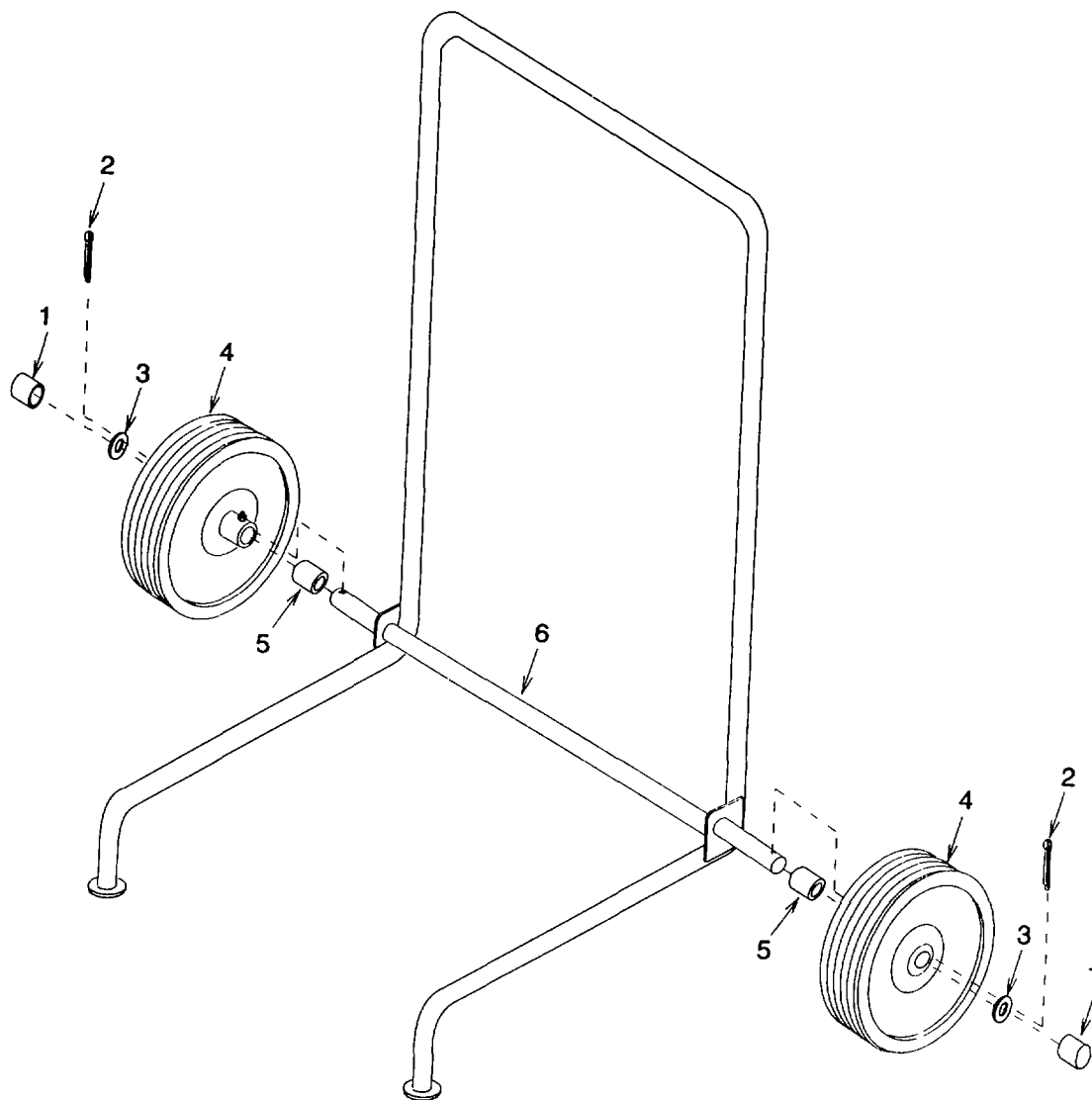

Figure 4-35. Hose Reel Cart

Section VII. PREPARATION FOR STORAGE OR SHIPMENT

4-33. PREPARATION FOR STORAGE

Before placing equipment in administrative storage, current maintenance services and Equipment Serviceable Criteria (ESC) evaluations should be completed, shortcomings and deficiencies should be corrected, and all Modification Work Orders (MWO's) should be applied.

- a. General. Perform both Operator and Unit PMCS prior to packaging, storing, or shipping. Package for storage in accordance with Army Master Data File, Packaging File. Secure equipment for transport in accordance with MIL-STD1186.
- b. Storage Site Selection. Inside storage is preferred for items selected for administrative storage. If inside storage is not available, trucks, vans, connect containers and other containers may be used. If equipment is to be stored in subfreezing temperatures, AFFF solution must be siphoned from tank and stored in an appropriate container.

NOTE

Container may expand in freezing temperatures.

- c. Administrative Storage of Equipment. Placement of equipment in administrative storage should be for short periods of time when a shortage of maintenance effort exists. Items should be in mission readiness within 24 hours or within the time factors as determined by the directing authority. During the storage period, appropriate maintenance records will be kept. Inspection for corrosion will be performed and necessary control measures taken.
- d. Short Term Storage - up to 45 days. No special handling is required other than protection from damage and the elements. During the storage period, appropriate maintenance records will be kept. Inspection for corrosion will be performed and necessary control measures taken.
- e. Intermediate Term Storage - 46 to 180 days. No special handling is required other than protection from damage and the elements. During the storage period, appropriate maintenance records will be kept. Inspection for corrosion will be performed and necessary control measures taken.
- f. Long Term Storage - excess of 180 days There is no time limit for this type of storage, however, the shelf life of the equipment is limited to 20 years.

(1) Trailer Mounted Extinguisher Assembly.

- (a) Siphon AFFF solution from tank.
- (b) Disconnect cylinder hoses and wrap fitting ends with a minimum of two wraps Packaging Cellulosic Cushioning Material, Appendix E, Section II, item 14. Secure with Waterproof Packaging Tape, Appendix E, Section II, item 15.
- (c) Install shipping caps onto cylinders.
- (d) Valves and gauges shall be wrapped with Flexible Waterproofed Grease proofed Barrier Material, Appendix E, Section II, item 16 and secured with Waterproof Packaging Tape, Appendix E, Section II, item 15.
- (e) Hose nozzles shall be wrapped with a minimum of two wraps Packaging Cellulosic Cushioning Material, Appendix E, Section II, item 14. Secure with Waterproof Packaging Tape, Appendix E, Section II, item 15.
- (f) The top layer of hose shall be protected by a layer of Polyolefin Plastic Sheet and Strip, Appendix E, Section II, item 17.
- (g) The wheel-mounted undercarriage shall be preserved in accordance with Preparation for Shipment and Storage of Wheeled Vehicles, MIL-V-62038.

- (2) Wheel Mounted Remote Hose Cart.
- (a) Hose nozzles shall be wrapped with a minimum of two wraps Packaging Cellulosic Cushioning Material, Appendix E, Section II, item 14. Secure with Waterproof Packaging Tape, Appendix E, Section II, item 15.
 - (b) The top layer of hose shall be protected by a layer of Polyolefin Plastic Sheet and Strip, Appendix E, Section II, item 17.
 - (c) The wheel-mounted undercarriage shall be preserved in accordance with Preparation for Shipment and Storage of Wheeled Vehicles, MIL-V-62038.
- (3) Fireman's Hood.
- (a) Each hood shall be carefully folded and placed in a snug-fitting Polyolefin Plastic Sheet and Strip bag, Appendix E, Section II, item 17, made in accordance with Sleeves and Tubing Bags, MIL-B-117.
 - (b) Pack hoods in Fiberboard Shipping Boxes, made in accordance with, PPP-B-636, type CF, class weather-resistant, variety SW, grade V3c. Each box to contain three hoods.
- (4) Fireman's Gloves.
- (a) Each pair of gloves shall be placed palms together with finger tips to gauntlet and Inserted Into a snug- fitting Polyolefin Plastic Sheet and Strip bag, Appendix E, Section II, item 17, made in accordance with Sleeves and Tubing Bags, MIL-B-117.
 - (b) Pack gloves, according to size, m Fiberboard Shipping Boxes, made in accordance with, PPP-B-636, type CF, class weather-resistant, variety SW, grade V3c. Each box to contain only one size glove.
- (5) Fireman's Coat.
- (a) Each coat shall be carefully folded and placed in a snug-fitting Polyolefin Plastic Sheet and Strip bag, Appendix E, Section II, item 17, made In accordance with Sleeves and Tubing Bags, MIL-B-117.
 - (b) Pack coats in Fiberboard Shipping Boxes, made m accordance with, PPP-B-636, type CF, class weather-resistant, variety SW, grade V3c.
- (6) Fireman's Trousers.
- (a) Each pair of trousers shall be carefully folded and placed in a snug-fitting Polyolefin Plastic Sheet and Strip bag, Appendix E, Section II, item 17, made in accordance with Sleeves and Tubing Bags, MIL-B-117.
 - (b) Pack trousers In Fiberboard Shipping Boxes, made in accordance with, PPP-B-636, type CF, class weather-resistant, variety SW, grade V3c.
- (7) Fireman's Boots.
- (a) Each pair of boots shall be placed sole to top and inserted into a snug-fitting Polyolefin Plastic Sheet and Strip bag, Appendix E, Section II, item 17, made m accordance with Sleeves and Tubing Bags, MIL-B-117.
 - (b) Pack boots In Fiberboard Shipping Boxes, made In accordance with, PPP-B-636, type CF, class weather-resistant, variety SW, grade V3c.

4-33 PREPARATION FOR STORAGE - continued

(8) Shoulder Harness.

- (a) Preserve the shoulder harness in accordance with Methods of Preservation, MIL-P-116, method IC-1 or IC-3.
- (b) Pack harnesses in Fiberboard Shipping Boxes, made in accordance with, PPP-B-636, type CF, class weather-resistant, variety SW, grade V3c.

(9) Dry Chemical (Purple K).

Pack the Potassium Bicarbonate Fire Extinguisher Dry Chemical, Appendix E, Section II, item 9, in a crate, made in accordance with, MIL-C-104.

(10) Fire Foam Liquid (AFFF).

Pack the Aqueous Film-Forming Foam (AFFF) Liquid Concentrate Fire Extinguishing Agent, Appendix E, Section II, item 8, in a crate, made in accordance with, MIL-C-104.

(11) Cylinders.

Install shipping caps onto any surplus cylinders and secure in a crate, made in accordance with, MIL-C104.

(12) Dry Chemical Fire Extinguishers (Hand Held, 20 Pound).

Pack fire extinguishers in Fiberboard Shipping Boxes, made in accordance with, PPP-B-636, type CF, class weather-resistant, variety SW, grade V3c.

CHAPTER 5

DIRECT SUPPORT MAINTENANCE INSTRUCTIONS

Section I. REPAIR PARTS, TOOLS, SPECIAL TOOLS, TEST, MEASUREMENT AND DIAGNOSTIC EQUIPMENT (TMDE), AND SUPPORT EQUIPMENT

5-1 REPAIR PARTS.

Repair parts are listed and illustrated in the Repair Parts and Special Tools List TM 10-4210-235-23P. Mandatory replacement parts are listed in the Mandatory Replacement Parts list, appendix H.

5-2 COMMON TOOLS AND EQUIPMENT.

Tools and test equipment requirements are listed in the Maintenance Allocation Chart TM 10-4210-235-13, appendix B. For authorized common tools and equipment, refer to the Modified Table of Organization and Equipment (MTOE), CTA 50-970, as applicable to your unit.

5-3 SPECIAL TOOLS

The following special tool is required for direct support maintenance. Use of this tool is described in Section III of this chapter.

Spanner Wrench (39428) 5472A1.

Section II. TROUBLESHOOTING

5-4 TROUBLESHOOTING

Direct support troubleshooting procedures are not required.

Section III. MAINTENANCE PROCEDURES

5-5. GENERAL

The procedures in this section have been arranged in the order in which the items appear in the Unit (0) maintenance level column on the Maintenance Allocation Chart (MAC) which is provided in Appendix B. Step-by-step procedures have been provided for all actions authorized to be performed by unit maintenance in the order in which they appear on the MAC. Actions authorized to be performed by direct support maintenance have been duly noted: step-by-step procedures for these actions may be found in chapter 5.

5-6 REGULATING VALVES TESTING AND REPAIR

This task covers:

a. **Testing**

b. **Repair**

INITIAL SETUP:ToolsEquipment Condition

General Mechanics Tool Kit, Appendix B, Section III,
item 1

Remove regulating valves (Para 4-16).

a. Testing

- (1) Connect each regulating valve inlet to a source of dry nitrogen at a pressure of 2000 psig (13800 kPa).
- (2) The outlet pressure must be $230 +10 -3$ psig ($1587 +69 -21$ kPa).

b. Repair

Repair is limited to replacement of any regulating valve not meeting pressure test requirements.

WARNING

- **Servicing the equipment with the system pressurized can result in serious personal injury.**
- **Discharging nitrogen in an enclosed, un-ventilated space can cause suffocation.**

5-7 DRY CHEMICAL NOZZLE REPAIR

This task covers:**a. Disassembly****b. Repair****c. Assembly**

INITIAL SETUP:Tools

General Mechanics Tool Kit, Appendix B, Section III, item 1

Spanner Wrench, Appendix B, Section III, item 5

Strap Wrench, Appendix B, Section III, item 3

Equipment Condition

Remove nozzles (para 4-14).

Materials/Pans

Gasket, Appendix H, item 11

Preformed Packing (2), Appendix H, Item 12

Gasket, Appendix H, item 14

Rod Wiper, Appendix H, item 15

Preformed Packing, Appendix H, item 16

Spring Pin, Appendix H, item 17

Antisieze Tape, Appendix E, Section II, item 4

a. Disassembly

- (1) Remove four screws (1) (fig. 5-1) and tie bar (2).
- (2) Remove nipple (3).
- (3) Using strap wrench, remove nozzle (4), gasket (5), nozzle tip (6), and sleeve (7). Discard gasket.
- (4) Using spanner wrench, remove forward valve seat (8) and preformed packing (9). Discard preformed packing.
- (5) Scribe an alignment line between handle (10) and valve body (11).
- (6) Remove four screws (12) and valve handle (10).
- (7) Un-screw rear seal bushing (13) from valve body (11). Manipulate lever (14) as necessary.
- (8) Carefully remove screw (1) (fig. 5-2), valve seal washer (2), gasket (3), spring retainer (4), spring (5), rod wiper (6), preformed packing (7), and rear seal bushing (8). Discard gasket, rod wiper, and preformed packing.
- (9) Remove preformed packing (9) and spring pin(10). Disassemble valve stem (11), lever (12), and two drive buttons (1). Discard preformed packing and spring pin.

b. Repair

Repair is limited to replacement of defective or damaged components only.

5-7 DRY CHEMICAL NOZZLE REPAIR. - continued

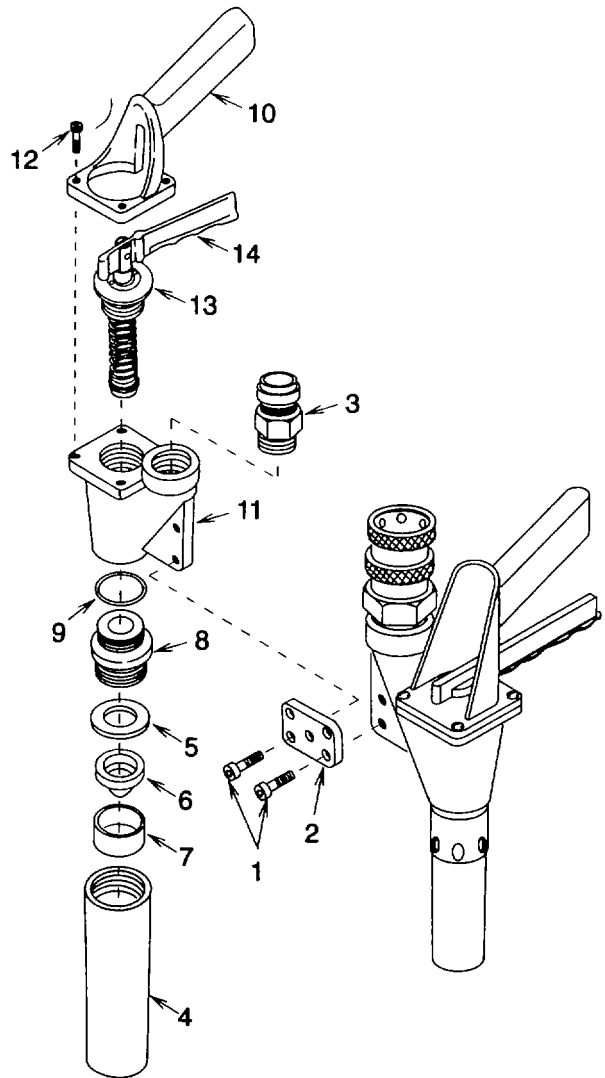

Figure 5-1. Dry Chemical Nozzle Assembly

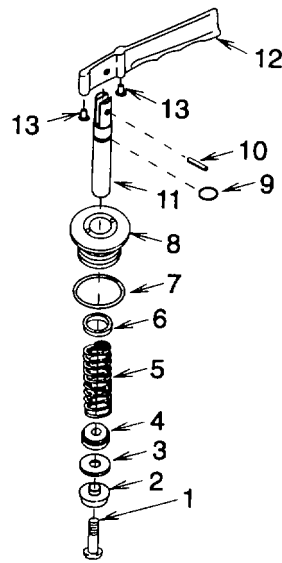

Figure 5-2. Valve Assembly

c. Assembly

- (1) Install drive buttons (13) (fig. 5-2) into lever (12).
- (2) Secure valve stem (11) to lever (12) using new spring pin (10).
- (3) Install new preformed packing (9) onto valve stem (11).
- (4) Install new preformed packing (7) onto rear seal bushing (8).
- (5) Slide rear seal bushing (8), new rod wiper (6), spring (5), spring retainer (4), new gasket (3), and valve seal washer (5) onto valve stem (11). Secure using screw (1) and tighten to 24 in. lb (3 Nm).
- (6) Install rear seal bushing (13) (fig. 5-1) into valve body (11) and tighten.
- (7) Install valve handle (10) and align with valve body (11) matching scribe line made during disassembly. Install four screws (12).
- (8) Install new preformed packing (9) onto forward valve seat (8).
- (9) Install forward valve seat (8) onto valve body (11) and tighten.
- (10) Install sleeve (7), nozzle tip (6), and new gasket (5) into nozzle (4).
- (11) Install nozzle (4) onto forward valve seat (8) and tighten.
- (12) Wrap antisieze tape around nipple (3) threads and install onto valve body (11). Tighten securely.
- (13) Install tie bar (2) and four screws (1).
- (14) Install nozzles per paragraph 4-14.

5-8. AFFF NOZZLE REPAIR**This task covers:****a. Disassembly****b. Repair****c. Assembly****INITIAL SETUP:**Tools

General Mechanics Tool Kit, Appendix B, Section III, Item 1

Spanner Wrench, Appendix B, Section III, item 5

Strap Wrench, Appendix B, Section III, item 3

Equipment Condition

Remove nozzles (para 4-14).

Materials/Parts

Gasket, Appendix H, Item 11

Preformed Packing (2), Appendix H, item 12

Gasket, Appendix H, item 14

Rod Wiper, Appendix H, item 15

Preformed Packing, Appendix H, item 16

Spring Pin, Appendix H, item 17

Antisieze Tape, Appendix E, Section II, item 4

a. Disassembly

- (1) Remove four screws (1) (fig. 5-3) and tie bar (2).
- (2) Remove coupler (3) and o-ring (4).
- (3) Remove set screw (5) and screen assembly (6).
- (4) Using strap wrench, remove barrel (7), gasket (8), and orifice plate (9). Discard gasket.
- (5) Using spanner wrench, remove forward valve seat (10) and preformed packing (11). Discard preformed packing. 6) Scribe an alignment line between handle (12) and valve body (13).
- (7) Remove four screws (14) and valve handle (12).
- (8) Unscrew rear seal bushing (15) from valve body (13). Manipulate lever (16) as necessary.
- (9) Carefully remove screw (1) (fig. 5-4), valve seal washer (2), gasket (3), spring retainer (4), spring (5), rod wiper (6), preformed packing (7), and rear seal bushing (8). Discard gasket, rod wiper, and preformed packing. 10) Remove preformed packing (9) and spring pin (10). Disassemble valve stem (11), lever (12), and two drive buttons (13). Discard preformed packing and spring pin.

b. Repair

Repair is limited to replacement of defective or damaged components only.

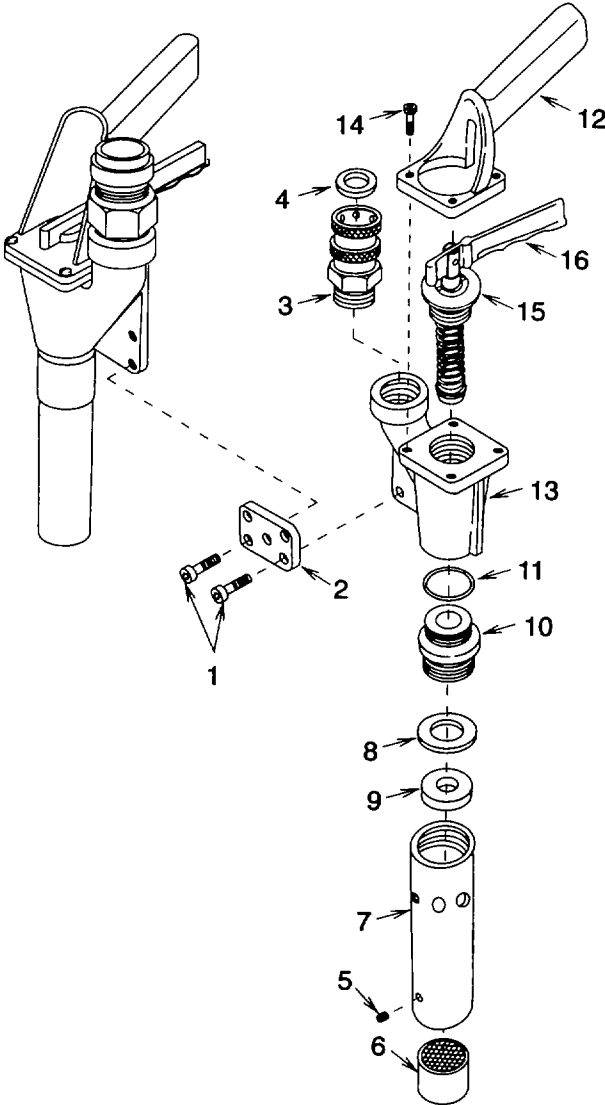

Figure 5-3. AFFF Nozzle Assembly

5-8 AFFF NOZZLE REPAIR. - continued

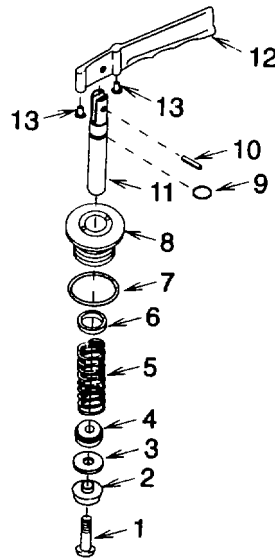

Figure 5-4. Valve Assembly

c. Assembly

- (1) Install drive buttons (13) (fig. 5-4) into lever (12).
- (2) Secure valve stem (11) to lever (12) using new spring pin (10).
- (3) Install new preformed packing (9) onto valve stem (11).
- (4) Install new preformed packing (7) onto rear seal bushing (8).
- (5) Slide rear seal bushing (8), new rod wiper (6), spring (5), spring retainer (4), new gasket (3), and valve seal washer (2) onto valve stem (11). Secure using screw (1) and tighten to 24 in. lb (3 Nm).
- (6) Install rear seal bushing (15) (fig. 5-3) into valve body (13) and tighten.
- (7) Install valve handle (12) and align with valve body (13) matching scribe line made during disassembly. Install four screws (14).
- (8) Install new preformed packing (11) onto forward valve seat (10).
- (9) Install forward valve seat (10) onto valve body (13) and tighten.
- (10) Install orifice plate (9) and new gasket (8) into barrel (7).
- (11) Install barrel (7) onto forward valve seat (10) and tighten.
- (12) Install screen assembly (6) into barrel (7), with fine mesh side out, and secure using set screw (5).
- (13) Wrap antisieze tape around coupler (3) threads and install onto valve body (13). Tighten securely. Install o-ring (4) into coupler.
- (14) Install tie bar (2) and four screws (1).
- (15) Install nozzles per paragraph 4-14.

5-9. SKID FRAME REPLACEMENT AND REPAIR

This task covers:**a. Removal****b. Repair****c. Installation**

INITIAL SETUP:Tools

General Mechanics Tool Kit, Appendix B, Section III, item 1

Lifting Device (Two Ton Capacity)

Equipment Condition

Remove cylinders (para 4-11).

Remove regulators (para 4-16).

Remove hose reel assembly (para 4-19).

Remove lift bar (para 4-21).

Remove dry chemical tank (para 4-22).

Remove AFFF tank (para 4-24).

Set parking brakes and lower jacks (para 4-29).

Remove rods (para 4-22 and 4-24).

Remove slide buttons, pads, and bushings (para 4-25).

Materials/Parts

Lock Washers (10), Appendix H, item 8

Lock Washers (16), Appendix H, item 9

Adhesive Remover, Appendix E, Section II, item 1

Rags, Appendix E, Section II, item 2

Adhesive, Appendix E, Section II, item 3

General Safety Instructions**WARNING****Frame can swing while suspended from a lifting device causing injury to personnel and/or damage to equipment.****NOTE****Disassemble equipment only to extent necessary for repair.**a. Removal (See figure 5-5.)

(1) Remove two nuts (1), lock washers (2), screws (3), and keepers (4).

(2) Remove 10 nuts (5), lock washers (6), flat washers (7), screws (8), and hold down clamps (9).

WARNING**Frame can swing while suspended from a lifting device causing injury to personnel and/or damage to equipment**

(3) Using lifting device, lift skid frame (10) off trailer (11) and lower to floor or ground.

b. Repair

Repair is limited to welding only. See TM 9-237, Welding Theory and Application.

5-9. SKID FRAME REPLACEMENT AND REPAIR. - continued

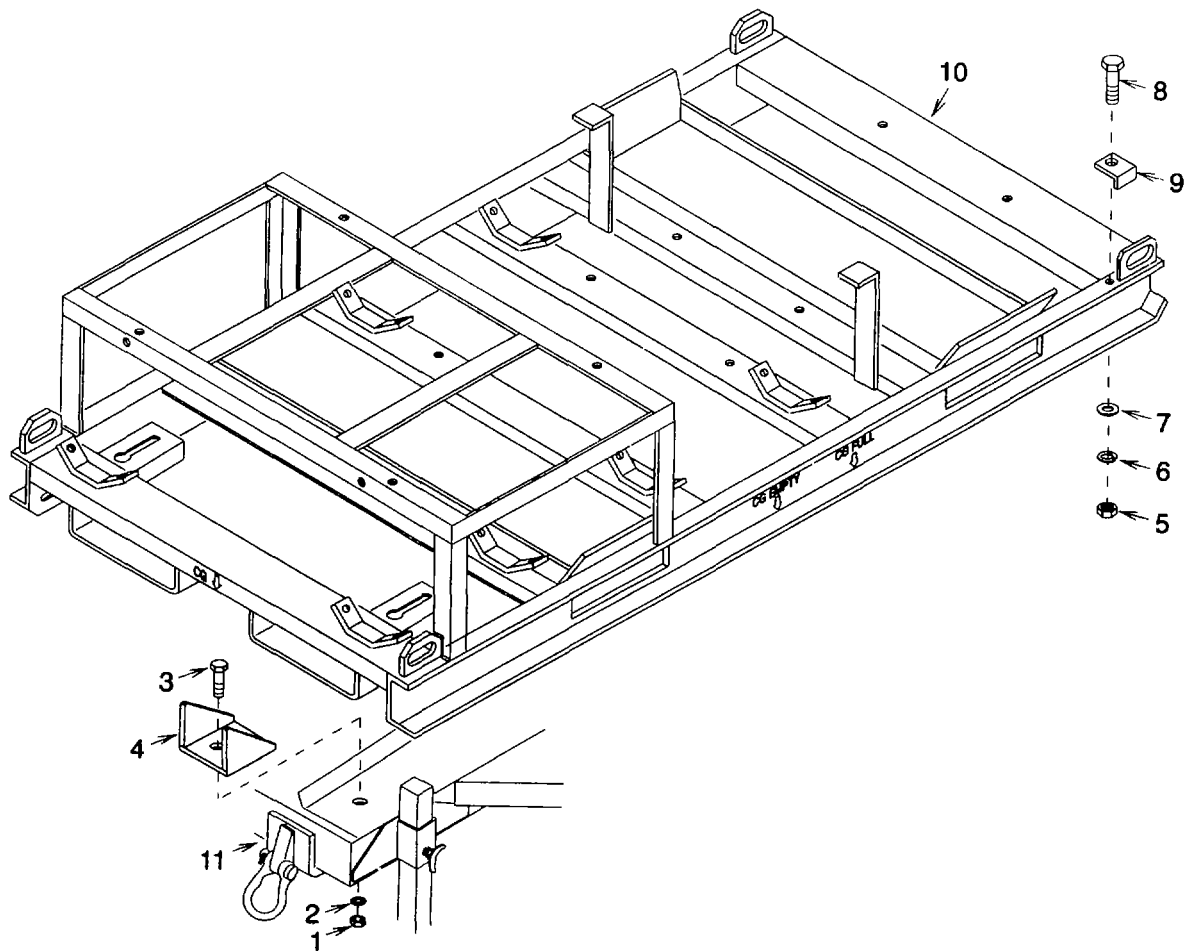

Figure 5-5. Skid Frame

c. Installation

- (1) Install two keepers (4), screws (3), lock washers (2), and nuts (1).

WARNING

Frame can swing while suspended from a lifting device causing injury to personnel and/or damage to equipment.

- (2) Using lifting device, lift skid frame (10) and lower onto trailer (11).
- (3) Install 10 hold down clamps (9), screws (8), flat washers (7), lock washers (6), and nuts (5).
- (4) Install slide buttons, pads, and bushings. See paragraph 4-25.
- (5) Install rods See paragraphs 4-22 and 4-24.

- (6) Install AFFF tank. See paragraph 4-24
- (7) Install dry chemical tank See paragraph 4-22
- (8) Install lift bar See paragraph 4-21.
- (9) Install hose reel assembly. See paragraph 4-19
- (10) Install regulators See paragraph 4-16.
- (11) Install cylinders. See paragraph 4-11.

5-11/(5-12 blank)

**APPENDIX A
REFERENCES**

A-1. SCOPE

This appendix lists all forms, field manuals, and technical manuals referenced in this manual.

A-2. PAMPHLETS

The Army Maintenance Management System (TAMMS) DA PAM 738-750

A-3. FORMS

Recommended Changes to Publications and Blank Forms DA 2028
 Product Quality Deficiency Report SF 368
 Equipment Inspection and Maintenance Worksheet DA 2404
 Report of Discrepancy SF 364

A-4. FIELD MANUALS

NBC Contamination Avoidance FM 3-3
 NBC Protection FM 3-4
 NBC Decontamination FM 3-5
 First Aid For Soldiers..... FM 21-11

A-5. TECHNICAL MANUALS

RPSTL for Fire Suppression Equipment Set..... TM 10-4210-235-23P
 Firefighting and Rescue in a Theater of Operations..... TM 5-315
 Destruction of Army Materiel to Prevent Enemy Use TM 750-244-3
 Welding Theory and Application..... TM 9-237

A-6. MISCELLANEOUS

Preparation for Shipment and Storage of Wheeled Vehicles MIL-V-62038
 Packaging File AMDF
 Cushioning, Anchoring, Bracing, Blocking and Waterproofing MIL-STD-1186
 Sleeves and Tubing Bags MIL-B-117
 Fiberboard Shipping Boxes PPP-B-636
 Methods of Preservation MIL-P- 116
 Sheathed, Nailed, and Bolted Lumber and Plywood Wood Crates..... MIL-C-104
 Expendable/Durable Items (except medical, class V repair parts, and heraldic items) CTA 50-790
 Army Medical Department Expendable/Durable Items CTA 8-100

APPENDIX B MAINTENANCE ALLOCATION CHART

Section I. INTRODUCTION

B-1. THE ARMY MAINTENANCE SYSTEM MAC.

a. This introduction (section 1) provides a general explanation of all maintenance and repair functions authorized at various maintenance levels under the standard Army Maintenance System concept.

b. The Maintenance Allocation Chart (MAC) in Section II designates overall authority and responsibility for the performance of maintenance functions on the Fire Suppression Equipment Set. The application of the maintenance functions the end. Item or component will be consistent with the capacities and capabilities of the designated maintenance levels which are shown on the MAC in column (4) as:

Unit - Includes two subcolumns, C (operator/crew) and O (unit) maintenance.

Direct Support - Includes an F subcolumn

General support - Includes an H subcolumn.

Depot - Includes a D subcolumn.

c. Section III lists the tools and test equipment (both special tools and common tool sets) required for each maintenance function as referenced from Section II.

d. Section IV contains supplemental instructions and explanatory notes for a particular maintenance function.

B-2. MAINTENANCE FUNCTIONS.

Maintenance functions will be limited to and defined as follows:

a. Inspect. To determine the serviceability of an Item by comparing its physical, mechanical and/or electrical characteristics with established standards through examination (e.g., by sight, sound, or feel).

b. Test. To verify serviceability by measuring the mechanical, pneumatic, hydraulic, or electrical characteristics of an item and comparing those characteristics with prescribed standards.

c. Service. Operations required periodically to keep an item in proper operating condition, e.g., to clean (includes decontaminate when required), to preserve, to drain, to paint, or to replenish fuel, lubricants, chemical fluids, or gases.

d. Adjust. To maintain or regulate, within prescribed limits, by bringing into proper position, or by setting the operating characteristics to specified parameters.

e. Align. To adjust specified variable elements of an item to bring about optimum or desired performance.

f. Calibrate. To determine and cause corrections to be made or to be adjusted on instruments or test, measuring, and diagnostic equipment used in precision measurement. Consists of comparisons of two instruments, one of which is a certified standard of known accuracy, to detect and adjust any discrepancy in the accuracy of the instrument being compared.

B-2 MAINTENANCE FUNCTIONS. - continued

g. Remove/Install. To remove and install the same item when required to perform service or other maintenance functions. Install may be the act of emplacing, seating, or fixing into position a spare, repair part, or module (component or assembly) in a manner to allow the proper functioning of an equipment or system.

h. Replace. To remove an unserviceable item and install a serviceable counterpart in its place. "Replace" is authorized by the MAC and assigned maintenance level is shown as the 3 rd position code of the SMR code.

i. Repair. The application of maintenance services¹, including fault location/troubleshooting², removal/installation, and disassembly/assembly³ procedures, and maintenance actions⁴ to identify troubles and restore serviceability to an item by correcting specific damage, fault, malfunction, or failure in a part, subassembly, module (component or assembly), end item, or system.

j. Overhaul. That maintenance effort (service/action) prescribed to restore an item to a completely serviceable/operational condition as required by maintenance standards in appropriate technical publications (i.e., DMWR). Overhaul is normally the highest degree of maintenance performed by the Army. Overhaul does not normally return an item to like new condition.

k. Rebuild. Consists of those services/actions necessary for the restoration of unserviceable equipment to a like new condition in accordance with original manufacturing standards. Rebuild is the highest degree of material maintenance applied to Army equipment. The rebuild operation includes the act of returning to zero those age measurements (e.g., hours/miles) considered in classifying Army equipment/components.

B.3 EXPLANATION OF COLUMNS IN THE MAC, SECTION II

a. Column 1. Group Number. Column 1 lists functional group code numbers, the purpose of which is to identify maintenance significant components, assemblies, subassemblies, and modules with the next higher assembly.

b. Column 2. Component/Assembly. Column 2 contains the names of components, assemblies, subassemblies, and modules for which maintenance is authorized.

c. Column 3. Maintenance Functions. Column 3 lists the functions to be performed on the item listed in column 2. (For detailed explanation of these functions, see paragraph B-2.)

¹Services Inspect, test, service, adjust, align, calibrate, and/or replace.

²Fault location/troubleshooting The process of investigating and detecting the cause of equipment malfunctioning; the act of isolating a fault within a system or unit under test (UUnI).

³Disassembly/assembly The step-by-step breakdown (taking apart) of a spare/functional group coded item to the level of its least component, that is assigned an SMR code for the level of maintenance under consideration (e.g., identified as maintenance significant).

⁴Actions Welding, grinding, riveting, straightening, facing, machining, and/or resurfacing.

d. Column 4. Maintenance Level. Column 4 specifies each level of maintenance authorized to perform each function listed in column 3, by indicating work time required (expressed as man-hours in whole hours or decimals) in the appropriate subcolumn. This work-time figure represents the active time required to perform that maintenance function at the indicated level of maintenance. If the number or complexity of the tasks within the listed maintenance function vary at different maintenance levels, appropriate work-time figures are to be shown for each level. The work-time figure represents the average time required to restore an item (assembly, subassembly, component, module, end item, or system) to a serviceable condition under typical field operating conditions. This time includes preparation time (including any necessary disassembly/assembly time), troubleshooting/fault location time, and quality assurance time in addition to the time required to perform the specific tasks identified for the maintenance functions authorized in the maintenance allocation chart. The symbol designations for the various maintenance levels are as follows:

C	Operator or Crew Maintenance
O	Unit Maintenance
F	Direct Support Maintenance
L	Specialized Repair Activity (SRA) ⁵
H	General Support Maintenance
D	Depot Maintenance

e. Column 5. Tools and Equipment Reference Code. Column 5 specifies, by code, those common tool sets (not individual tools) common, TMDE, and special tools, special TMDE, and special support equipment required to perform the designated function. Codes are keyed to tools and test equipment in section III.

f. Column 6. Remarks. When applicable, this column contains a letter code, in alphabetical order, which is keyed to the remarks contained in Section IV.

B-4. EXPLANATION OF COLUMNS IN TOOL AND TEST EQUIPMENT REQUIREMENTS, SECTION III

- a. Column 1. Reference Code. The tool and test equipment reference code correlates with a code used in the MAC, Section , Column 5.
- b. Column 2. Maintenance level. The lowest level of maintenance authorized to use the tool or test equipment.
- c. Column 3. Nomenclature. Name or identification of the tool or test equipment
- d. Column 4. National Stock Number. The National stock number of the tool or test equipment
- e. Column 5. Tool Number. The manufacturer's part number or type number.

B-5. EXPLANATION OF COLUMNS IN REMARKS, SECTION IV.

- a. Column 1. Remarks Code. The code recorded in column 6, Section II.
- b. Column 2. Remarks. This column lists information pertinent to the maintenance function being performed as indicated in the MAC, Section II.

⁵ This maintenance level is not included in Section II, column (4) of the Maintenance Allocation Chart. Functions to this level of maintenance are identified by a work-time figure in the "H" column of Section II, column (4), and an associated reference code is used in the Remarks column (6). This code is keyed to Section IV, Remarks, and the SRA complete repair application is explained there.

**SECTION II. MAINTENANCE ALLOCATION CHART
FOR
FIRE SUPPRESSION EQUIPMENT SET**

(1) Group Number	(2) Component/Assembly	(3) Maintenance Function	(4) Maintenance Level					(5) Tools & Eqpt. Ref Code	(6) Remarks Code
			Unit		Direct Support	General Support	Depot		
			C	O	F	H	D		
00	Fire Suppression Equipment Set								
01	Clothing and Supplies	Inspect Repair	0.1	0.5				B	
02	Trailer Mounted Extinguisher Assy								
0201	Extinguisher, Skid Mounted	Inspect Replace Repair	0.2	2.0 3.0			2 2	B	
020101	Cylinder Assy	Inspect Repair Replace	0.1	0.5			1.0 1	A	
020102	Name Plates	Inspect Replace	0.1	0.3			2		
020103	Accessories	Inspect Repair	0.1	0.5			1	B	
020103 01	Gage Assy, Liquid Level Measure	Inspect Repair Replace	0.1	0.5 0.1			2 1	B	
020104	Nozzle Assy	Inspect Replace Repair	0.1	0.3	1.0		1 3, 5	B	
020105	Hoses	Inspect Replace	0.1	0.5			2	B	
020106	Regulators	Inspect Replace Test Repair	0.1	0.1 0.5	0.5 0.7		1 3		
020107	Fire Hose Assembly	Inspect Replace Repair	0.1	0.5 1.0			2 2, 4		

(1) Group Number	(2) Component/Assembly	(3) Maintenance Function	(4) Maintenance Level					(5) Tools & Eqpt. Ref Code	(6) Remarks Code
			Unit		Direct Support	General Support	Depot		
			C	O	F	H	D		
020108	Hose Roller Assy	Inspect Replace Repair	0.1	0.2 0.7				1 1	
020109	Hose Reel Sub Assy	Inspect Replace Repair	0.1	0.7 3.0				2 2	B
020109 01	Swivel (Hose Reel)	Inspect Replace Repair	0.1	0.3 0.5				2 2	B
020110	Lift Bar	Inspect Replace Repair	0.1	0.3 0.2				1 1	B
020111	Dry Chemical Tank Assy (With Piping)	Inspect Service Replace Repair	0.1	0.5 1.5 2.0				2 2	B
020111 01 Repair	Tube Assy, Gas (Dry Chemical Tank)	Inspect Replace	0.3	0.5 0.8				2 2	B
020112	Heater Assy AFFF Tank	Inspect Replace Repair	0.1	0.8 0.4				1 2	B
020113	AFFF Tank (With Piping)	Inspect Service Replace Repair	0.1 0.5	1.5 3.0				2 2	B
020114	Skid Frame	Inspect Replace Repair	0.1		20.0 20.0			3 3	B
0202	Extinguisher Trailer	Inspect Replace Repair	0.2	2.0 3.0				2 2	B
020201	Jack Stand Rear	Inspect Replace	0.1	0.3					

(1) Group Number	(2) Component/Assembly	(3) Maintenance Function	(4) Maintenance Level					(5) Tools & Eqpt. Ref Code	(6) Remarks Code
			Unit		Direct Support	General Support	Depot		
			C	O	F	H	D		
020202	Jack (Front)	Inspect Replace	0.1	0.2				2	
020203	Tires/Wheels	Inspect Service Replace Repair	0.1	0.1 1.0 1.0				2 2 2	B
020204	Parking Brakes	Inspect Adjust Replace Repair	0.1	1.0 2.0 2.0				1 2 2	B
03	Auxiliary Mobile Hose Reel Cart Assy								
0301	Fire Hose Nozzle Assy t	Inspect Replace Repair	0.1	0.3	1.0			1 3, 5	B
0302	Twin Agent Hose Assy	Inspect Replace Repair	0.1	0.5 1.0				2 2, 4	
0303	Hoses (Cart)	Inspect Replace	0.1	0.5				2	B
0304	Hose Reel Sub Assembly	Inspect Replace Repair	0.1	0.7 3.0				2 2	B
030401	Swivel (Hose Reel)	Inspect Replace Repair	0.1	0.3 0.5				2 2	B
0305	Cart, Hose Reel	Inspect Replace Repair	0.1	0.5 0.8				1 1	B

**Section III. TOOL AND TEST EQUIPMENT REQUIREMENTS
FOR
FIRE SUPPRESSION EQUIPMENT SET**

TOOL OR TEST EQUIPMENT REF CODE	MAINTENANCE CATEGORY	NOMENCLATURE	NATIONAL STOCK NUMBER	TOOL NUMBER
NOTE				
Standard tools and test equipment in the following kits are adequate to accomplish the maintenance functions listed in Section II:				
1	O-F	Tool Kit, General Mechanics	5180-00-177-7033	SC 5100-90-CL-N26
2	O	Shop Equip, Auto Org #1 Comm	4910-00-754-0654	SC 4910-95-CL-A74
3	F	Shop Equipment Electrical Repair	4940-00-294-9517	SC 4940-94-CL-BOS5
4	O	Hose Fitting Installation Tool	4210-01-240-3100	(64903) 05272
5	F	Spanner Wrench		(39428) 5472A1
6	O	Tank Lifting Tool		(94833) 140K0084

**Section IV. REMARKS
FOR
FIRE SUPPRESSION EQUIPMENT SET**

Reference Code	Remarks
A	Repair authorized at special repair authority.
B	The only authorized repair is replacement of components

APPENDIX C
COMPONENTS OF END ITEM (COEI) AND BASIC ISSUE ITEMS (BII) LISTS

Section I. INTRODUCTION

C-1. SCOPE.

This appendix lists components of end Item and basic issue items for the Fire Suppression Equipment Trailer Set to help you inventory the items for safe and efficient operation of the equipment.

C-2 GENERAL.

The Components of End Item (COEI) and Basic Issue Items (BII) Lists are divided into the following sections:

a. Section II. Components of End Item. This listing is for Information purposes only, and is not authority to requisition replacements. These items are part of the Fire Suppression Equipment Trailer Set. As part of the end item, these items must be with the end item whenever It is issued or transferred between property accounts. Items of COEI are removed and separately packaged for transportation or shipment only when necessary. Illustrations are furnished to help you find and identify the items.

b. Section III. Basic Issue Items. These essential items are required to place the Fire Suppression Equipment Trailer Set in operation, operate It, and to do emergency repairs. Although shipped separately packaged, BII must be with the Fire Suppression Equipment Trailer Set during operation and when It is transferred between property accounts. This list is your authority to request/requisition them for replacement based on authorization of the end item by the TOE/MTOE. Illustrations are furnished to help you find and identify the items.

C-3 EXPLANATION OF COLUMNS

The following provides an explanation of columns found In the tabular listings:

- a. Column (1), Illus. Number, gives you the number of the item Illustrated.
- b. Column (2), National Stock Number, Identifies the stock number of the item to be used for requisitioning purposes
- c. Column (3), Description and Usable On Code, identifies the Federal item name (m all capital letters) followed by a minimum description when needed. The last line below the description is the Commercial and Government Entity Code (CAGEC) (m parentheses) and the part number. If the item you need is not the same for different models of the equipment, a Usable On Code will appear on the right side of the description column on the same line as the part number.
- d. Column (4), U/I (unit of issue), indicates how the item is issued for the National Stock Number shown In column two.
- e. Column (5), Qty Rqd, indicates the quantity required.

Section II. COMPONENTS OF END ITEM

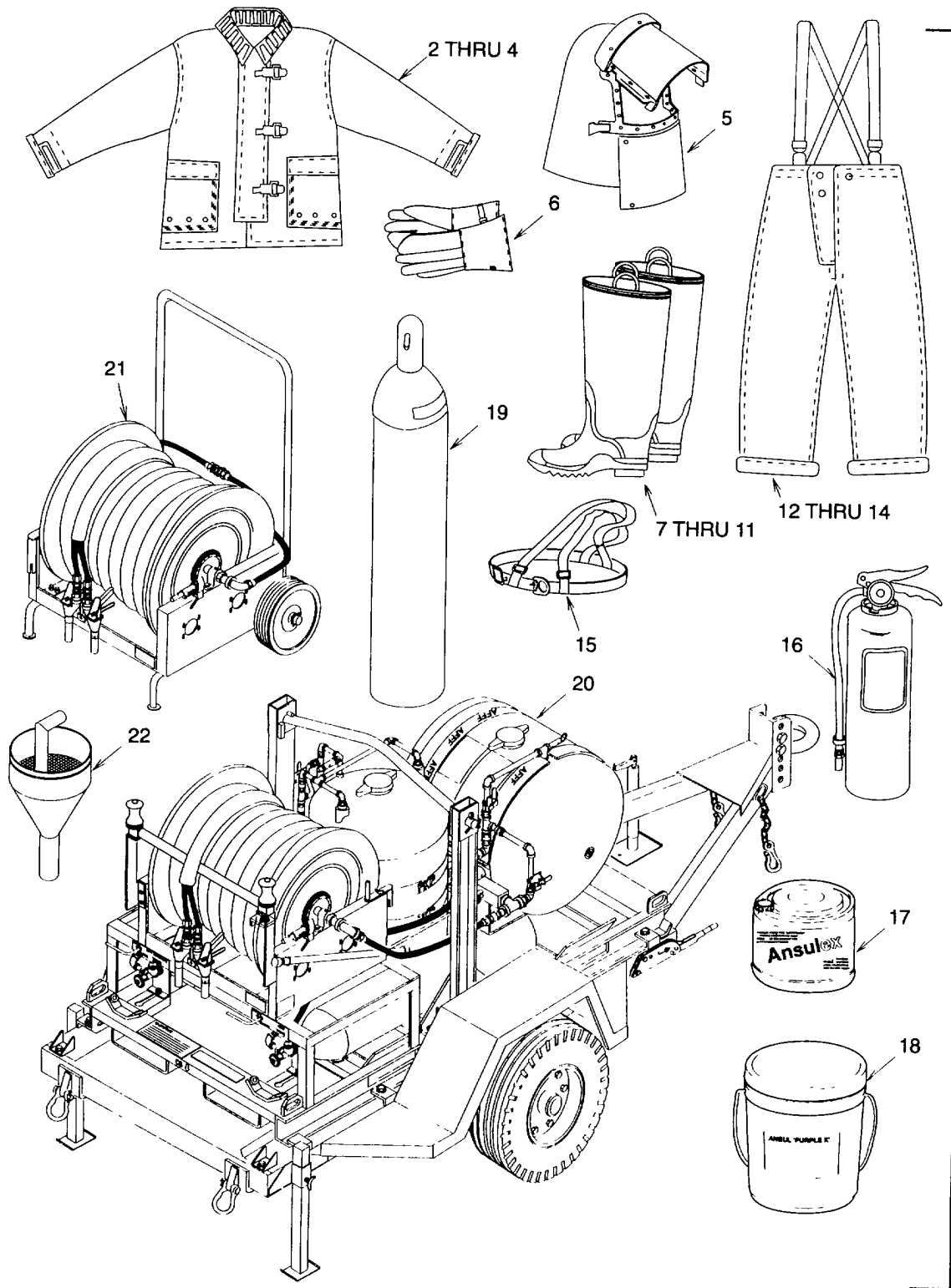

(1) ILLUS NUMBER	(2) NATIONAL STOCK NUMBER	(3) DESCRIPTION CAGEC AND PART NUMBER	(4) USABLE ON CODE U/I	(5) QTY RQD
1	4210-01-370-4912	FIRE SUPPRESSION EQUIPMENT (97403) 13228E3419 (94833) FSES-1 Consisting of the following:	EA	1
2	8415-01-266-8418	COAT, FIREMAN'S, ALUMINIZED (81349) MIL-C-29145, SMALL	EA.	1
3	8415-01-266-8419	COAT, FIREMAN'S, ALUMINIZED (81349) MIL-C-29145, MEDIUM	EA.	1
4	8415-01-266-8420	COAT, FIREMAN'S, ALUMINIZED (81349) MIL-C-29145, LARGE	EA	1
5	8415-01-268-3472	HOOD, FIREMAN'S, ALUMINIZED (81349) MIL-H-24925, TYPE I	EA	3
6	8415-01-259-1710	GLOVES, FIREMAN'S ALUMINIZED (81348) MIL-G-87077, LARGE	EA.	4
7	8430-00-147-1032	BOOTS, FIREMAN'S (81348) MIL-B-2885, TYPE II, SIZE 6	EA.	1
8	8430-00-147-1033	BOOTS, FIREMAN'S (81348) MIL-B-2885, TYPE II, SIZE 7	EA.	1
9	8430-00-147-1034	BOOTS, FIREMAN'S (81348) MIL-B-2885, TYPE II, SIZE 8	EA.	1
10	8430-00-147-1035	BOOTS, FIREMAN'S (81348) MIL-B-2885, TYPE II, SIZE 9	EA.	1
11	8430-00-147-1036	BOOTS, FIREMAN'S (81348) MIL-B-2885, TYPE II, SIZE 10	EA.	1
12	8415-01-267-1145	TROUSER, FIREMAN'S, ALUMINIZED (81348) MIL-T-29146, SMALL	EA.	1
13	8415-01-267-1146	TROUSER, FIREMAN'S, ALUMINIZED (81348) MIL-T-29146, MEDIUM	EA	1
14	8415-01-267-1147	TROUSER, FIREMAN'S, ALUMINIZED (81348) MIL-T-29146, LARGE	EA.	1
15		HARNES, SHOULDER (97403) 13228E3459	EA.	1
16	4210-00-965-1108	EXTINGUISHER, FIRE, DRY CHEMICAL, 20 LB (81348) A-A-393, TYPE I, CLASS 2, SIZE 20	EA.	5
17	4210-01-056-8343	FOAM, LIQUID, FIRE, (5 GAL.) (81349) MIL-F-24385, (TYPE 6)	EA	5
18	4210-00-752-9343	DRY CHEMICAL, FIRE, PURPLE K, (50 LB CAN) (81348) 0-D-1407	EA.	36
19	3835-01-210-5594	CYLINDER, NITROGEN, WITH VALVE, 300 CU. FT. (97403) 13228E3460	EA.	8
20		TRAILER MOUNTED EXTINGUISHER ASSEMBLY (97403) 13228E3507	EA.	1
21		CART, AUXILIARY MOBILE HOSE REEL (64903) 04955	EA.	1
22	4210-01-254-1038	Dry Chemical Funnel (64903) 01539	EA.	1

Section III. BASIC ISSUE ITEMS

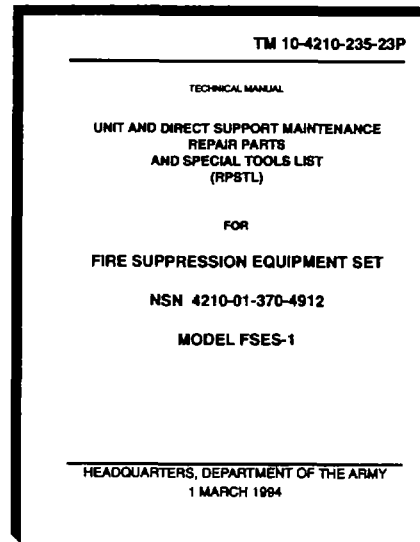
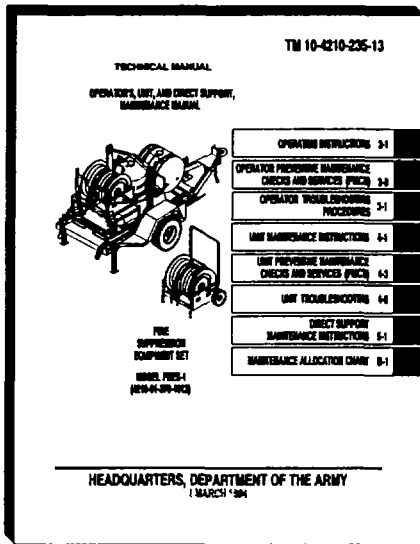

(1) ILLUS NUMBER	(2) NATIONAL STOCK NUMBER	(3) DESCRIPTION CAGEC AND PART NUMBER	USABLE ON CODE	(4) U/I	(5) QTY RQD
1		Department of the Army Technical Manual; Operator's, Unit, and Direct Support, Maintenance Manual TM 5-4210-235-13		EA.	1
2		Department of the Army Technical Manual; Unit and Direct Support Maintenance Repair Parts and Special Tools List (RPSTL) TM 5-4210-235-23P		EA.	1

**APPENDIX D
ADDITIONAL AUTHORIZATION LIST (AAL)**

Section I. INTRODUCTION

D-1 SCOPE

This appendix lists additional items you are authorized for the support of the Fire Suppression Equipment Set.

D-2 GENERAL

This list Identifies Items that do not have to accompany the Fire Suppression Equipment Set and that do not have to be turned in with It These Items are authorized to you by CTA, MTOE, TDA, or JTA.

D-3 EXPLANATION OF LISTING

National stock numbers, descriptions, and quantities are provided to help you Identify and request the additional items you require to support this equipment.

Section II. ADDITIONAL AUTHORIZATION ITEMS LIST

(1) NATIONAL STOCK NUMBER	(2) DESCRIPTION CAGEC AND PART NUMBER USABLE ON CODE	(3) U/M	(4) QTY AUTH
7520-00-559-9618	Cotton Duck Case	EA.	1
6150-00-485-6149	Power Cable Assembly, 25 foot	EA.	1
8415-01-266-8418	Fireman's Coat (1FM91) 118761, Small	EA.	Variable
8415-01-266-8419	Fireman's Coat (1FM91) 118761, Medium	EA.	Variable
8415-01-266-8420	Fireman's Coat (1FM91) 118761, Large	EA.	Variable
8430-00-147-1032	Fireman's Boots (57420) 31040, Size 6	EA.	Variable
8430-00-147-1033	Fireman's Boots (57420) 31040, Size 7	EA.	Variable
8430-00-147-1034	Fireman's Boots (57420) 31040, Size 8	EA.	Variable
8430-00-147-1035	Fireman's Boots (57420) 31040, Size 9	EA.	Variable
8430-00-147-1036	Fireman's Boots (57420) 31040, Size 10	EA.	Variable
8415-01-267-1145	Fireman's Trousers (1FM91) 218761, Small	EA.	Variable
8415-01-267-1146	Fireman's Trousers (1FM91) 218761, Medium	EA.	Variable
8415-01-267-1147	Fireman's Trousers (1FM91) 218761, Large	EA.	Variable

**APPENDIX E
EXPENDABLE AND DURABLE ITEMS LIST**

Section I. INTRODUCTION

E-1 SCOPE

This appendix lists expendable and durable items that you will need to operate and maintain the Fire Suppression Equipment Trailer Set. This listing is for information only and is not authority to requisition the listed items. These items are authorized to you by CTA 50-790, Expendable/Durable Items (except medical, class V repair parts, and heraldic items), or CTA 8-100, Army Medical Department Expendable/Durable Items.

E-2 EXPLANATION OF COLUMNS.

- a. Column 1 Item Number. This number is assigned to the entry in the listing and is referenced in the narrative instructions to identify the item (e.g. "Adhesive Remover, Appendix E, item 1")
- b. Column 2 Level This column identifies the lowest level of maintenance that requires the item.
- c. Column 3. National Stock Number. This is the national stock number assigned to the item which you can use to requisition it.
- d. Column 4 Item name, description, Commercial and Government Entity Code (CAGEC), and part number. This provides the other information you need to identify the item.
- e. Column 5. Unit of measure. This code shows the physical measurement or count of an item, such as gallon, dozen, gross, etc.

SECTION II. EXPENDABLE AND DURABLE ITEMS LIST

(1) ITEM NUMBER	(2) LEVEL	(3) NATIONAL STOCK NUMBER	(4) ITEM NAME, DESCRIPTION CAGEC AND PART NUMBER	(5) U/M
1	0		Safety Solvent Cleaner, (OAMVO) 117-01	gal
2	0	7920-00-205-1711	Rags	pg
3	0	3040-00-664-0439	Adhesive, General Purpose, 1 Pint Container	ea
4	0	8030-00-761-1584	Tape, Antisieze, Polytetrafluroethylene, MIL-T-27730, Size 1	roll
5	0		Tape, Pressure Sensitive Adhesive, Electrical Insulation, MIL-T-47325	roll
6	0	8040-00-083-8403	Adhesive, Sealant, MIL-A-46106, Type I	Pt
7	0	6850-00-109-4362	Compound, Heat Sink, Silicone, MIL-C-47113	Pt
8	C	4210-01-056-8343	Foam, Liquid, Fire, MIL-F-24385 (Type 6)	gal
9	C	4210-00-752-9343	Dry Chemical, Fire, Purple K	lb
10	F	6850-00-880-7616	Grease, Sillcone, MIL-S-8660B	az
11	F		Grease, General Purpose, MIL-L-10924	oz
12	0	8135-01-372-8907	Tie, Strip	ea
13	0	5350-00-192-5047	Cloth, Abrasive	pg
14	0		Cellulosic, Packaging, cushioning maternal, A-A-898	roll
15	0	7510-00-266-5006	Tape, Waterproof Packaging, PPP-T-60, Type IV	roll
16	0	8135-00-664-6958	Greaseproofed, Waterproof, Flexible Barrier Material, PPP-C-843, Type II Class B	roll
17	0	8135-00-068-9466	Polyolefin, Plastic Sheet & Strip Material, L-P-378	roll

**APPENDIX F
LUBRICATION INSTRUCTIONS**

See unit PMCS for lubrication instructions.

APPENDIX G
ILLUSTRATED LIST OF MANUFACTURED ITEMS

Manufactured items not required.

**APPENDIX H
MANDATORY REPLACEMENT PARTS LIST**

ITEM NUMBER	NOMENCLATURE	CAGEC	PART NUMBER
1	Lock Washer	96906	MS35338-140
2	Lock Washer	96906	MS35338-141
3	Lock Washer	96906	MS35338-143
4	Cotter Pin	64903	05747
5	Spring Pin	96906	MS171560
6	Lock Washer	96906	MS35338-138
7	Terminal Lug	96906	MS25036-108
8	Lock Washer	96906	MS35338-48
9	Lock Washer	96906	MS35338-139
10	Cotter Pin	96906	MS24665-355
11	Gasket	64903	01609
12	Preformed Packing	96906	MS28775-218
13	Self Locking Nut	96906	MS33588
14	Seal	64903	01519
15	Rod Wiper	64903	01522
16	Preformed Packing	96906	MS28775-111
17	Spring Pin	96906	MS171588
18	Gasket	64903	05138
19	Preformed Packing	96906	MS28775-222
20	Preformed Packing	96906	MS28775-224
21	Self Locking Nut	96906	MS33688
22	Spring Pin	96906	MS171688
23	Self Locking Nut	96906	MS21042-5
24	Self Locking Nut	63716	XB0414
25	Cotter Pin	63716	165649
26	Lock Washer	15460	5-4
27	Self Locking Nut	96906	MS21042-6
28	Neoprene, Washer	OLB76	24-02-94-42-05
29	Drive Screw	96906	MS21318-27
30	Cotter Pin	96906	MS24665-283
31	Self Locking Nut	96906	MS35338-46

ITEM NUMBER	NOMENCLATURE	CAGEC	PART NUMBER
32	Strip Tie	24871	602RE
33	Self Locking Nut	63716	XB1459
34	Self Locking Nut	15460	6-10

H-2

GLOSSARY

Section I. ABBREVIATIONS

A	Amps
AAL	Additional Authorization List
AC	Alternating Current
AFFF	Aqueous Film Forming Foam
ATTN	Attention
BII	Basic Issue Items
Blvd.	Boulevard
C	Centigrade
CAGEC	Commercial And Government Entity Code
cm	Centimeter
COEI	Components Of End Items
CPC	Corrosion Prevention and Control
cyl	Cylinder
D C	District of Columbia
DA	Department of Army
DMWR	Depot Maintenance Work Requirement
e.g	For Example
ea	Each
EIR	Equipment Improvement Recommendation
ESC	Equipment Serviceable Criteria
F	Fahrenheit
fig	Figure
ft	Foot
gal	Gallon
Hz	Hertz
ID	Identification
In.	Inch Pound
Illus	Illustration
in	Inch
ISO	Isolation
kg	Kilogram
kPa	KiloPascals
l	Liter
lb	Pound
m.	Meter
MAC	Maintenance Allocation Chart
MO	Missouri
MTOE	Modified Table of Organization and Equipment
MWO	Modification Work Order
NBC	Nuclear Biological and Chemical
No	Number
oz.	Ounce
para	Paragraph
pg	Package
ph	Phase
PMCS	Preventive Maintenance Checks and Services
psi	Pounds Per Square Inch
Qty	Quantity
Rqd	Required
sec	Second
SMR	Source Maintenance Recoverability
St	Saint

ABBREVIATIONS - continued

TM	Technical Manual
TMDE	Test Measurement and Diagnostic Equipment
TOE	Table of Organization and Equipment
U S	United States
U/I	Unit of Issue
U/M	Unit of Measure
UUT	Unit Under Test
V.	Volts
vac	Volts Alternating Current
w.	Watt

Section II. DEFINITION OF UNUSUAL TERMS

Purple K: Powdered potassium bicarbonate.

INDEX

Subject, Paragraph

A

Accessories Replacement, 4-13
 AFFF Nozzle Repair, 5-8
 AFFF Solution Frozen, 4-9
 AFFF System, 2-2
 AFFF Tank Heater Assembly Replacement and Repair, 4-23
 AFFF Tank Replacement and Repair, 4-24
 Assembly And Preparation For Use, 2-9
 Auxiliary Cart, 1-9, 2-5

C

Common Tools and Equipment, 5-2
 Corrosion Prevention and Control (CPC), 1-3
 Cylinder Assembly Replacement, 4-11

D

Decals and Instruction Plates, 2-11
 Destruction Of Army Material To Prevent Enemy Use, 1-4
 Dry Chemical Nozzle Repair, 5-7
 Dry Chemical System, 2-3
 Dry Chemical Tank Replacement and Repair, 4-22
 Dusty or Sandy Environment, 2-16

E

Emergency Procedures, 2-17
 Equipment Characteristics, Capabilities, and Features, 1-6
 Equipment Data, 1-7
 Extinguisher Trailer Assembly Repair and Replacement, 4-30
 Extreme Cold, 2-14
 Extreme Heat, 2-13

F

Fire Fighting Agents Will Not Discharge From The Nozzles, 3-2
 Fire Hose Replacement and Repair, 4-17
 Fire Suppression Equipment Set, 1-8
 Fire Suppression Equipment Set, 2-1

G

General, 2-7, 3-1, 3-3, 4-10, 4-6, 4-8, 5-4, 5-5

Subject, Paragraph

H

Hose Reel Assembly Repair and Replacement, 4-19
 Hose Reel, 24
 Hose Roller Assembly Replacement, 4-18
 Hoses Replacement, 4-15,4-31

I

Installation, 4-5

J

Jack (Front) Replacement, 4-27
 Jack Stand (Rear) Replacement, 4-26
 Lift Bar Repair, 4-21

M

Maintenance Forms and Procedures, 1-2

N

Name Plates Replacement, 4-12
 Nozzle Bracket and Quick Disconnect Replacement, 4-14
 Nuclear, Biological, and Chemical (NBC) Decontamination Procedures, 2-18

O

Operating Procedures, 2-10

P

Parking Brakes Adjustment Repair and Replacement, 4-29
 PMCS Procedures, 2-8, 4-7
 Preparation for Movement, 2-12
 Preparation for Storage, 4-33
 Processing, 4-4

R

Regulating Valves Testing And Repair, 5-6
 Regulators Replacement, 4-16
 Remote Auxiliary Hose Reel Cart Repair and Replacement, 4-32
 Repair Parts, 5-1
 Reporting Equipment Improvement Recommendation (EIR), 1-5
 Rewind Brake Assembly Replacement, 4-20

Subject, Paragraph

S

Salt Air or Sea Spray, 2-15
Scope, 1-1
Skid Frame Repair, 4-25
Skid Frame Replacement and Repair, 5-9
Special Tools, 4-1, 5-3

Subject, Paragraph

T

Tires/Wheels Repair and Replacement, 4-28
Trailer, 2-6

U

Unloading, 4-2
Unpacking, 4-3

Index-2

TM 10-4210235-13

By Order of the Secretary of the Army:

Official:

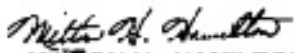
MILTON H. HAMILTON
*Administrative Assistant to the
Secretary of the Army*
07489

GORDON R. SULLIVAN
*General, United States Army
Chief of Staff*

DISTRIBUTION:

To be distributed in accordance with DA Form 12-31-E, block no. 6242, requirements for TM 10-4210-235-13.

RECOMMENDED CHANGES TO EQUIPMENT TECHNICAL PUBLICATIONS



THEN...JOT DOWN THE
DOPE ABOUT IT ON THIS FORM.
CAREFULLY TEAR IT OUT, FOLD IT
AND DROP IT IN THE MAIL.

SOMETHING WRONG WITH PUBLICATION

FROM: (PRINT YOUR UNIT'S COMPLETE ADDRESS)

DATE SENT

PUBLICATION NUMBER

PUBLICATION DATE

PUBLICATION TITLE

BE EXACT PIN-POINT WHERE IT IS

PAGE
NO.

PARA-
GRAPH

FIGURE
NO.

TABLE
NO.

IN THIS SPACE, TELL WHAT IS WRONG
AND WHAT SHOULD BE DONE ABOUT IT.

TEAR ALONG PERFORATED LINE

PRINTED NAME, GRADE OR TITLE AND TELEPHONE NUMBER

SIGN HERE

THE METRIC SYSTEM AND EQUIVALENTS

Linear Measure

1 centimeter = 10 millimeters = .39 inch
 1 decimeter = 10 centimeters = 3.94 inches
 1 meter = 10 decimeters = 39.37 inches
 1 dekameter = 10 meters = 32.8 feet
 1 hectometer = 10 dekameters = 328.08 feet
 1 kilometer = 10 hectometers = 3,280.8 feet

Weights

1 centigram = 10 milligrams = .15 grain
 1 decigram = 10 centigrams = 1.54 grains
 1 gram = 10 decigrams = .035 ounce
 1 dekagram = 10 grams = .35 ounce
 1 hectogram = 10 dekagrams = 3.52 ounces
 1 kilogram = 10 hectograms = 2.2 pounds
 1 quintal = 100 kilograms = 220.46 pounds
 1 metric ton = 10 quintals = 1.1 short tons

Cubic Measure

1 cu. centimeter = 1000 cu. millimeters = .06 cu. inch
 1 cu. decimeter = 1000 cu. centimeters = 61.02 cu in.
 1 cu. meter = 1000 cu. decimeters = 35.31 cu. feet

Square measure

1 sq. centimeter = 100 sq. millimeters = .155 sq. in.
 1 sq. decimeter = 100 sq. centimeters = 15.5 inches
 1 sq. meter (centare) = 100 sq. decimeters = 10.76 feet
 1 sq. dekameter (are) = 100 sq. meters = 1,076.4 sq. ft.
 1 sq. hectometer (hectare) = 100 sq. dekameters = 2.47 acres
 1 sq. kilometer = 100 hectometers = .386 sq. miles

Liquid Measure

1 dekaliter = 10 liters = 2.64 gallons
 1 hectoliter = 10 dekaliters = 26.42 gallons
 1 kiloliter = 10 hectoliters = 264.18 gallons
 1 liter = 10 deciliters = 33.81 fl. ounces
 1 centiliter = 10 milliliters = .34 fl. ounce
 1 deciliter = 10 centiliters = 3.38 fl. ounces
 1 metric ton = 10 quintals = 1.1 short tons

Approximate Conversion Factors

To change	To	Multiply by	To change	To	Multiply by
inches	centimeters	2.540	ounce inches	newton-meters	.0070062
feet	meters	.305	centimeters	inches	.394
yards	meters	.914	meters	feet	3.280
miles	kilometers	1.609	meters	yards	1.094
sq. inches	sq. centimeters	6.451	kilometers	miles	.621
sq. feet	sq. meters	.093	sq. centimeters	sq. inches	.155
sq. yards	sq. meters	.836	sq. meters	sq. yards	10.764
sq. miles	sq. kilometers	2.590	sq. kilometers	sq. miles	1.196
acres	sq. hectometers	.405	sq. hectometers	acres	2.471
cubic feet	cubic meters	.028	cubic meters	cubic feet	35.315
cubic yards	cubic meters	.765	milliliters	fluid ounces	.034
fluid ounces	milliliters	29.573	liters	pints	2.113
pints	liters	.472	liters	quarts	1.057
quarts	liters	.946	grams	ounces	.035
gallons	liters	3.785	kilograms	pounds	2.205
ounces	grams	28.349	metric tons	short tons	1.102
pounds	kilograms	.454	pound-feet	newton-meters	1.356
short tons	metric tons	.907			
pound inches	newton-meters	.11296			

Temperature (Exact)

°F Fahrenheit temperature

5/9 (after subtracting 32)

Celsius Temperature °C

